

Rosemount™ 648 Wireless Temperature Transmitter

with Rosemount X-well™ Technology



WirelessHART



Safety messages

Rosemount 648 Wireless Hardware Revision	1
HART® Device Revision	4
Device Install Kit/DD Revision	Device Revision 4, DD Revision 1 or higher

NOTICE

Read this manual before working with the product. For personal and system safety, and for optimum product performance, make sure to thoroughly understand the contents before installing, using, or maintaining this product

For technical assistance, contacts are listed below:

Customer Central

Technical support, quoting, and order related questions.

United States:	1-800-999-9307 (7:00 a.m. to 7:00 p.m. CST)
Asia Pacific:	65 777 8211
Europe/Middle East/Africa:	49 (8153) 9390

North American Response Center

Equipment service needs

1-800-654-7768 (24 hours - includes Canada)

Outside of these areas, contact your local Emerson representative.

The Rosemount 648 Wireless and all other wireless devices should be installed only after the Wireless Gateway has been installed and is functioning properly. Wireless devices should also be powered up in order of proximity from the Wireless Gateway, beginning with the closest. This will result in a simpler and faster network installation.

Shipping considerations for wireless products (lithium batteries: Black Power Module, model number 701PBKKF):

The unit was shipped to you without the power module installed. Remove the power module prior to shipping the unit. Each Black Power Module contains two “C” size primary lithium-thionyl chloride battery. Primary lithium batteries are regulated in transportation by the U. S. Department of Transportation, and are also covered by IATA (International Air Transport Association), ICAO (International Civil Aviation Organization), and ARD (European Ground Transportation of Dangerous Goods). It is the responsibility of the shipper to ensure compliance with these or any other local requirements. Consult current regulations and requirements before shipping.

Power Module Considerations (Black Power Module, model number 701PBKKF):

The Black Power Module with the wireless unit contains two “C” size primary lithium-thionyl chloride battery (model number 701PGNKF). Each battery contains approximately 2.5 grams of lithium, for a total of 5 grams in each pack. Under normal conditions, the battery materials are self-contained and are not reactive as long as the batteries and the pack integrity are maintained. Care should be taken to prevent thermal, electrical or mechanical damage. Contacts should be protected to prevent premature discharge. Battery hazards remain when cells are discharged. Power modules should be stored in a clean and dry area. For maximum power module life, storage temperature should not exceed 30 °C.

⚠ CAUTION

The products described in this document are NOT designed for nuclear-qualified applications.

Using non-nuclear qualified products in applications that require nuclear-qualified hardware or products may cause inaccurate readings.

For information on Rosemount nuclear-qualified products, contact a Emerson Sales Representative.

⚠ WARNING

Follow instructions

Failure to follow these installation guidelines could result in death or serious injury.

Ensure only qualified personnel perform the installation.

⚠ WARNING

Explosions

Explosions could result in death or serious injury.

Installation of this transmitter in an explosive environment must be in accordance with the appropriate local, national, and international standards, codes, and practices. Review the approvals section of this manual for any restrictions associated with a safe installation.

Before connecting a communicator in an explosive atmosphere, ensure the instruments in the segment are installed in accordance with intrinsically safe or non-incendive field wiring practices.

Process leaks

Process leaks could result in death or serious injury.

Install and tighten process connectors before applying pressure.

Electrical shock

Electrical shock could cause death or serious injury.

Avoid contact with the leads and terminals. High voltage that may be present on leads can cause electrical shock.

This device complies with Part 15 of the FCC Rules. Operation is subject to the following conditions:

This device may not cause harmful interference.

This device must accept any interference received, including interference that may cause undesired operation.

This device must be installed to ensure a minimum antenna separation distance of 8-in. (20 cm) from all persons.

The power module may be replaced in a hazardous area. The power module has surface resistivity greater than one gigaohm and must be properly installed in the wireless device enclosure. Care must be taken during transportation to and from the point of installation to prevent electrostatic charge build-up.

Physical access

Unauthorized personnel may potentially cause significant damage to and/or misconfiguration of end users' equipment. This could be intentional or unintentional and needs to be protected against.

Physical security is an important part of any security program and fundamental to protecting your system. Restrict physical access by unauthorized personnel to protect end users' assets. This is true for all systems used within the facility.

Contents

Chapter 1	Introduction.....	7
	1.1 Using this manual.....	7
	1.2 Product recycling/disposal.....	7
Chapter 2	Configuration.....	9
	2.1 Overview.....	9
	2.2 Safety messages.....	9
	2.3 Sensor connections.....	11
	2.4 Bench top configuration.....	15
	2.5 HART menu tree.....	17
	2.6 Fast Key sequence.....	20
	2.7 Basic setup.....	20
	2.8 Calibration.....	23
	2.9 Advanced setup.....	27
	2.10 Remove power module.....	31
Chapter 3	Installation.....	33
	3.1 Overview.....	33
	3.2 Safety messages.....	33
	3.3 Wireless considerations.....	34
	3.4 Physical installation.....	36
	3.5 Ground the transmitter.....	40
	3.6 Fast Key sequence.....	42
Chapter 4	Commissioning.....	43
	4.1 Overview.....	43
	4.2 Safety messages.....	43
	4.3 Verify operation.....	45
Chapter 5	Operation and maintenance.....	49
	5.1 LCD display screen messages.....	49
	5.2 Power module replacement.....	57
Chapter 6	Troubleshooting.....	59
	6.1 Overview.....	59
Appendix A	Reference data.....	67
	A.1 Ordering information, specifications, and drawings.....	67
	A.2 Product certifications.....	67
Appendix B	Mapping for Non-DD Based Integration with Host Systems.....	69
	B.1 Alert message mapping.....	69

B.2 Mapping of device variable index numbers..... 71

1 Introduction

1.1 Using this manual

The sections in this manual provide information on installing, operating, and maintaining the Rosemount 648 Wireless Temperature Transmitter with *WirelessHART™* protocol. The sections are organized as follows:

[Configuration](#) provides instruction on commissioning and operating Rosemount 648 Wireless. Information on software functions, configuration parameters, and online variables is also included.

[Installation](#) contains mechanical and electrical installation instructions.

[Commissioning](#) contains techniques for properly commissioning the device.

[Operation and maintenance](#) contains operation and maintenance techniques.

[Reference data](#) contains troubleshooting tips as well as information to contact technical support over the phone or through email.

[Reference data](#) supplies procedure on how to get the specifications, ordering information, and product certification.

[Mapping for Non-DD Based Integration with Host Systems](#) contains important alerts in the HART® command 48 additional status field for the Rosemount 648 Wireless.

1.2 Product recycling/disposal

Consider recycling equipment and packaging. Dispose of the product and packaging in accordance with local and national legislation.

2 Configuration

2.1 Overview

This section contains information on configuration and verification that should be performed prior to installation. Field Communicator and AMS Device Manager instructions are given to perform configuration functions. For convenience, Field Communicator Fast Key sequences are labeled “Fast Keys” for each software function below the appropriate headings.

Sensor input trim example

Fast Keys sequence	1,2,3, etc.
--------------------	-------------

2.2 Safety messages

Instructions and procedures in this section may require special precautions to ensure the safety of the personnel performing the operations. Refer to the following safety messages before performing an operation preceded by this symbol.

⚠ WARNING

Follow instructions

Failure to follow these installation guidelines could result in death or serious injury.
Ensure only qualified personnel perform the installation.

Explosions

Explosions could result in death or serious injury.

Installation of this transmitter in an explosive environment must be in accordance with the appropriate local, national, and international standards, codes, and practices. Review the approvals section of this manual for any restrictions associated with a safe installation.

Before connecting a communicator in an explosive atmosphere, ensure the instruments in the segment are installed in accordance with intrinsically safe or non-incendive field wiring practices.

Process leaks

Process leaks could result in death or serious injury.
Install and tighten process connectors before applying pressure.

⚠ WARNING

Electrical shock

Electrical shock could cause death or serious injury.

Avoid contact with the leads and terminals. High voltage that may be present on leads can cause electrical shock.

This device complies with Part 15 of the FCC Rules. Operation is subject to the following conditions:

This device may not cause harmful interference.

This device must accept any interference received, including interference that may cause undesired operation.

This device must be installed to ensure a minimum antenna separation distance of 8-in. (20 cm) from all persons.

The power module may be replaced in a hazardous area. The power module has surface resistivity greater than one gigaohm and must be properly installed in the wireless device enclosure. Care must be taken during transportation to and from the point of installation to prevent electrostatic charge build-up.

Physical access

Unauthorized personnel may potentially cause significant damage to and/or misconfiguration of end users' equipment. This could be intentional or unintentional and needs to be protected against.

Physical security is an important part of any security program and fundamental to protecting your system. Restrict physical access by unauthorized personnel to protect end users' assets. This is true for all systems used within the facility.

2.3 Sensor connections

The Rosemount 648 Wireless is compatible with a number of RTD and thermocouple sensor types. [Figure 2-1](#) shows the correct input connections to the sensor terminals on the transmitter. To ensure a proper sensor connection, anchor the sensor lead wires into the appropriate compression terminals and tighten the screws.

Make sensor connections through the cable entry in the side of the connection head. Be sure to provide adequate clearance for cover removal.

When using Rosemount X-well Technology, the Rosemount 648 Wireless is required to be assembled to a Rosemount 0085 Pipe Clamp RTD Sensor in a direct mount 3-wire configuration.

Thermocouple or millivolts inputs

The thermocouple can be connected directly to the transmitter. Use appropriate thermocouple extension wire if mounting the transmitter remotely from the sensor.

RTD or ohm inputs

The wireless transmitter will accept a variety of RTD or ohmic configurations, including 2-, 3-, or 4-wire connections. If the device is mounted remotely using a 3- or 4-wire connection, it will operate withing specifications without recalibration for lead wire resistances of up to 5 ohms per lead (equivalent to 500 ft. of 20 AWG wire). In this case, the leads between the RTD and transmitter is recommended to be shielded.

2.3.1 Sensor lead wire resistance effect—RTD input

Since the lead wires are part of the RTD circuit, the lead wire resistance needs to be compensated for to achieve the best accuracy. This becomes especially critical in applications where long sensor and/or lead wires are used. There are three lead wire configurations commonly available.

A 4-wire design is ideal because the lead wire resistance is inconsequential to the measurement. It uses a measurement technique where a very small constant current of about 150 micro amps is applied to the sensor through two leads and the voltage developed across the sensor is measured over the other two wires with a high-impedance and high resolution measuring circuit. In accordance with Ohm's Law, the high impedance virtually eliminates any current flow in the voltage measurement leads and therefore the resistance of the leads is not a factor.

In a 3-wire configuration, compensation is accomplished using the third wire with the assumption that it will be the same resistance as the other two wires and the same compensation is applied to all three wires.

In a 2-wire configuration there can be no compensation for lead wire resistance since the lead wires are in series with the element and appear to the transmitter as part of the sensor's resistance causing inherent accuracy degradation.

Table 2-1: Examples of Approximate Basic Error

Sensor input	Approximate basic error
4-wire RTD	Negligible ⁽¹⁾

Table 2-1: Examples of Approximate Basic Error (continued)

Sensor input	Approximate basic error
3-wire RTD	Error in reading is equivalent to unbalanced lead wire resistance ⁽²⁾
2-wire RTD	Error in reading equivalent total lead wire resistance

- (1) Independent of lead wire resistance up to 5Ω per lead.
 (2) Unbalanced lead wire resistance is the maximum resistance differences between any of two leads.

Figure 2-1: Sensor Wiring

Thermocouple/mV

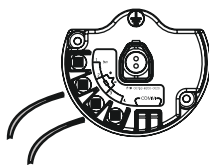

4-Wire RTD and Ω

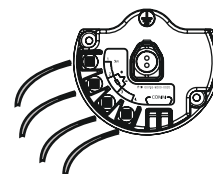

3-Wire RTD and Ω

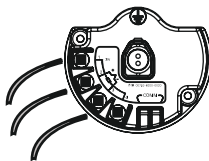

2-Wire RTD and Ω

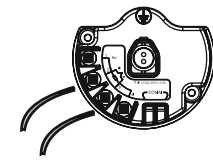
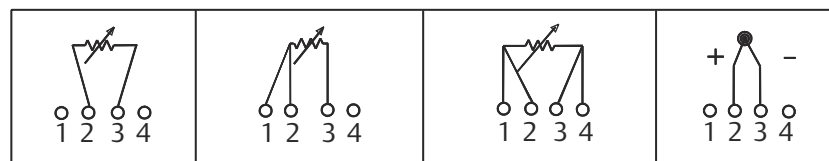

Figure 2-2: Sensor Connections



2-wire
RTD and Ω

3-wire
RTD and Ω

4-wire
RTD and Ω

T/C and mV

Note

Emerson provides 4-wire sensors for all single element RTDs. Use these RTDs in 3-wire configurations by leaving the unneeded leads disconnected and insulated with electrical tape.

2.3.2 Lead wire configuration

Figure 2-3: Rosemount 68Q, 78 Standard Temperature Range, and 58 RTD Sensor Single Element

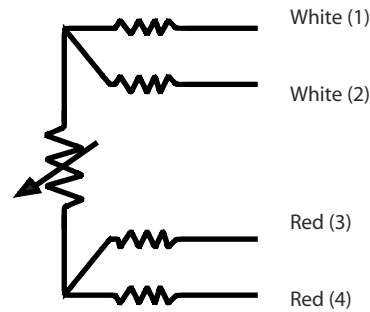

Figure 2-4: Rosemount 65, 78 High Temp, 68 RTD Single Element

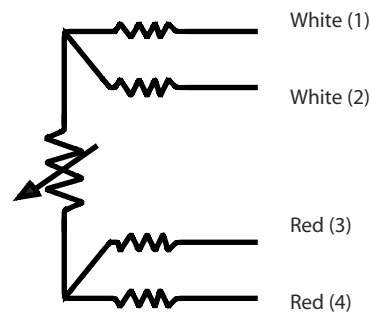
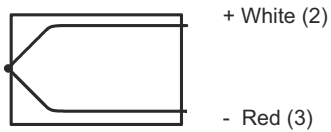
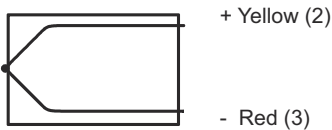

Figure 2-5: Rosemount 183 Thermocouple

Type J



Type K



Type E

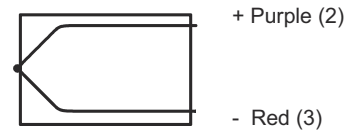

Type T

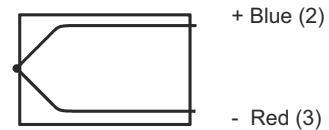
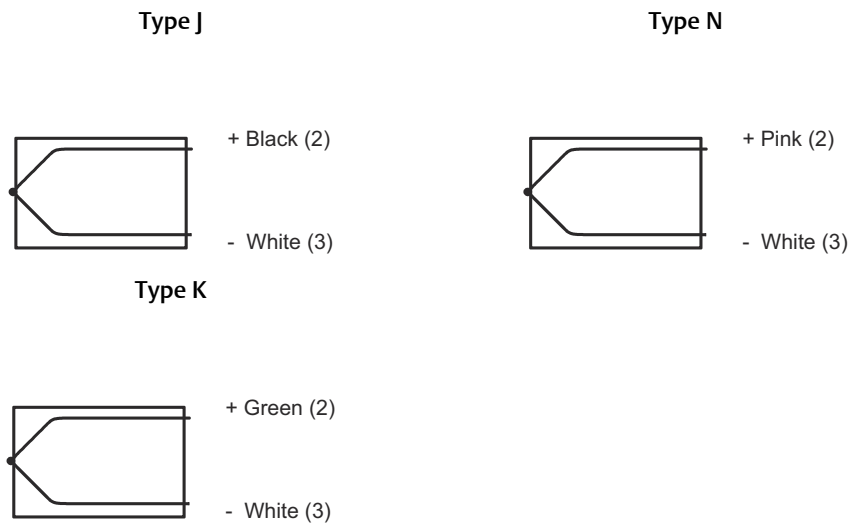

Figure 2-6: Rosemount 185 Thermocouple



Note

Wire color examples apply to Rosemount sensors, but will vary by manufacturer.

2.3.3 Sensor leads

If the sensor is installed in a high-voltage environment and a fault condition or installation error occurs, the sensor leads and transmitter terminals could carry lethal voltages. Use extreme caution when making contact with the leads and terminals.

Use the following steps to wire the sensor and supply power to the transmitter:

1. Remove the transmitter enclosure cover (if applicable).
2. Attach the sensor leads according to the wiring diagrams.
3. Connect the power module.
4. Verify the connection by observing the LCD display (if applicable).
5. Reattach and tighten the cover (if applicable).

2.4 Bench top configuration

Bench top configuration consists of testing the transmitter and verifying transmitter configuration data. The transmitter must be configured before installation, which may be performed either directly or remotely. Direct configuration can be performed using a Field Communicator, AMS Device Manager, AMS Wireless Configurator, or any *WirelessHART™* Communicator. Remote configuration can be performed using AMS Device Manager, AMS Wireless Configurator, or the Wireless Gateway.

The power module must be installed to provide power to the transmitter for configuration. To communicate to the transmitter, begin by removing the power module-side housing cover, indicated as “Field terminals” by text located on the side of the device. This will expose the terminal block and HART Communication terminals, which are labeled “COMM”. Connect the power module to supply power for configuration. See [Figure 2-7](#).

Figure 2-7: Connection Diagram for Rosemount 648 Wireless and Field Communicator

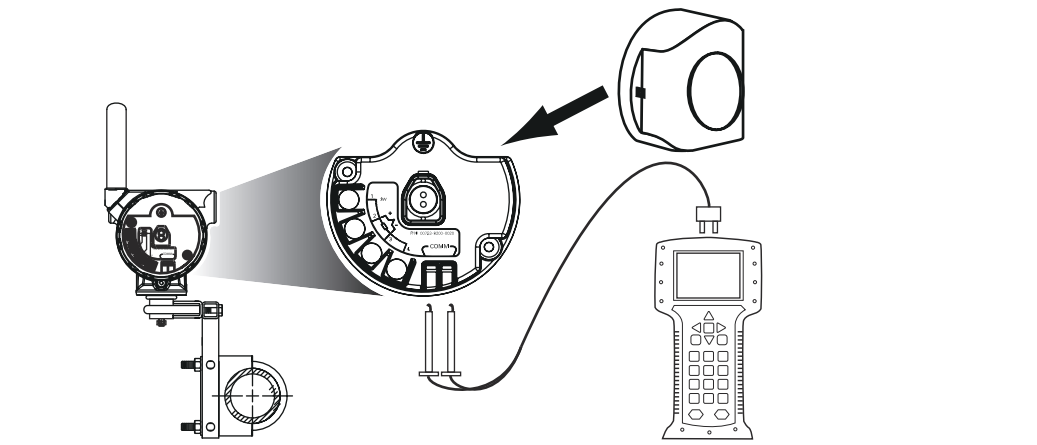

2.4.1 Field Communicator

When performing device configuration directly, connect the bench equipment as shown in [Figure 2-7](#) above, and turn on the field communicator by pressing the ON/OFF key. When using a Field Communicator, any configuration changes must be sent to the transmitter by using the Send key (F2).

The Field Communicator will search for a HART®-compatible device and indicate when the connection is made. If the Field Communicator fails to connect, it will indicate that no device was found. If this occurs, refer to [Troubleshooting](#).

Note

For HART Wireless transmitter communication via a Field Communicator, a Rosemount 648 Wireless Device Dashboard (DD) is required. Rosemount 648 Wireless Transmitters equipped with Rosemount X-well Technology requires DD revision 648 Dev. 4 Rev. 1 or higher to view Rosemount X-well functionality. To obtain the latest DD, visit Emerson.com/Field-Communicator.

2.4.2 AMS Device Manager and AMS Wireless Configurator

When configuring the Rosemount 648 Wireless using AMS Device Manager or AMS Wireless Configurator, double click the Rosemount 648 Wireless device icon (or right click and select Configure/Setup), then select the **Configure/Setup** tab. AMS Device Manager configuration changes are implemented when the **Apply** button is selected.

Note

For HART Wireless transmitter communication via AMS Device Manager, a Rosemount 648 Wireless Device Dashboard (DD) is required. Rosemount 648 Wireless Transmitters equipped with Rosemount X-well Technology requires DD revision 648 Dev. 4 Rev. 1 or higher to view Rosemount X-well functionality. To obtain the latest DD, visit the [Emerson Easy Upgrade site](#).

2.4.3 Wireless Gateway

The Rosemount 648 Wireless supports limited remote configuration through the Wireless Gateway. The Gateway allows configuration of the following device parameters: HART Tag, Short Tag, Descriptor, Engineering Units, Update Rate and Range Values.

2.4.4 Default settings

The Rosemount 648 Wireless default configuration is shown below:

Sensor type	Pt 100 ($\alpha = 0.00386$)
Engineering units	°C
Number of lead wires	4
Network ID	Factory-generated network parameters
Join Key	Factory-generated network parameters
Update rate	1 minute

Note

The C1 option code can be used to enable factory configuration of the Update Rate, Date, Descriptor and Message fields. This code is not required to have the factory configure the Sensor Type, Connection or the Self Organizing Network parameters.

2.4.5 Device sensor configuration

Every temperature sensor has unique characteristics. In order to ensure the most accurate measurement, the device should be configured to match the specific sensor that it will be connected to. Prior to installation, verify the configuration and connection settings of the temperature sensor through a Field Communicator or AMS Device Manager.

2.5 HART menu tree

This section displays the navigation paths to the primary commands and options via a Field Communicator. For HART Wireless transmitter communication via a Field Communicator, a Rosemount 648 Wireless Device Dashboard (DD) is required. Rosemount 648 Wireless Transmitters with Rosemount X-well Technology requires DD revision 648 Dev. 4 Rev.1 or higher to view Rosemount X-well functionality. To obtain the latest DD, visit the Emerson.com/Field-Communicator.

Figure 2-8: Overview

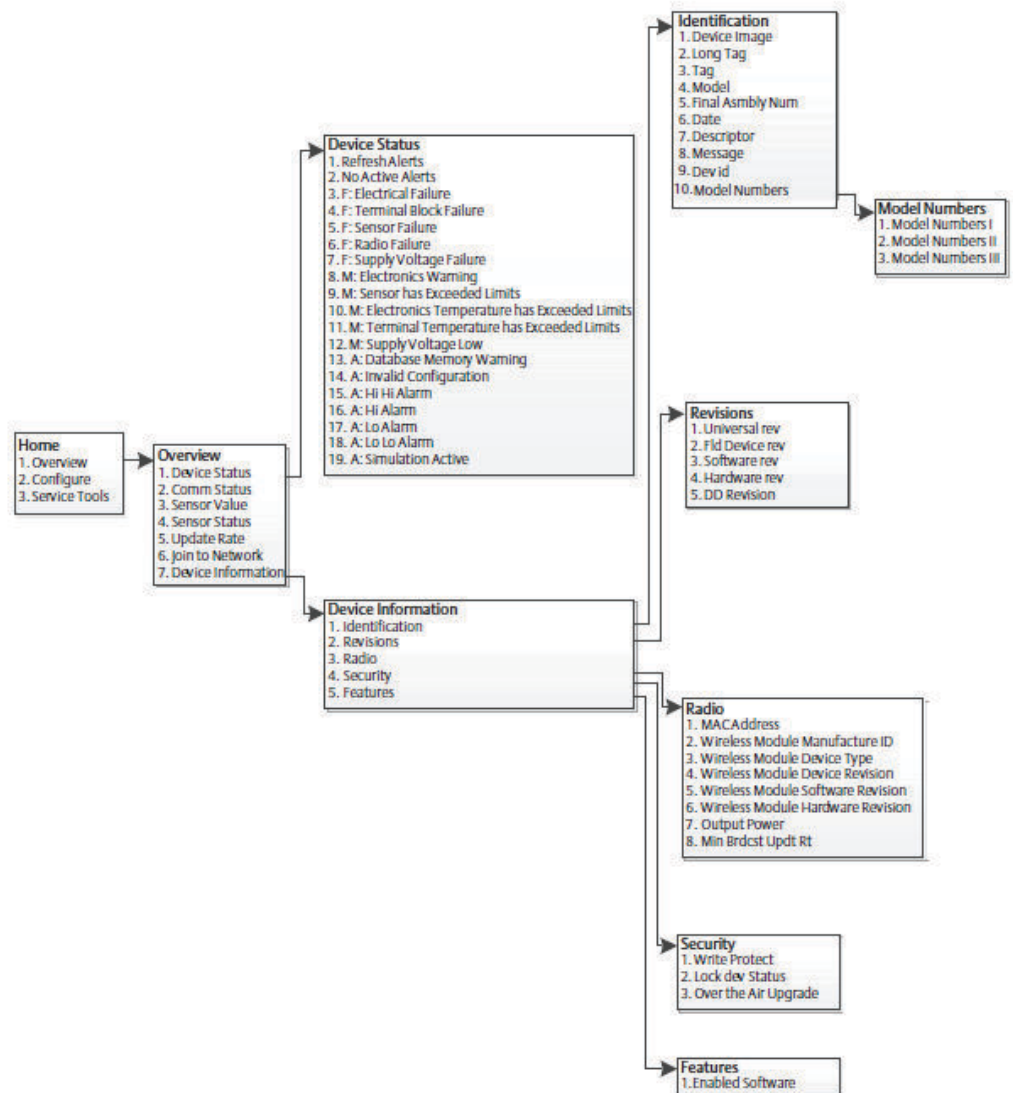

Figure 2-9: Configure

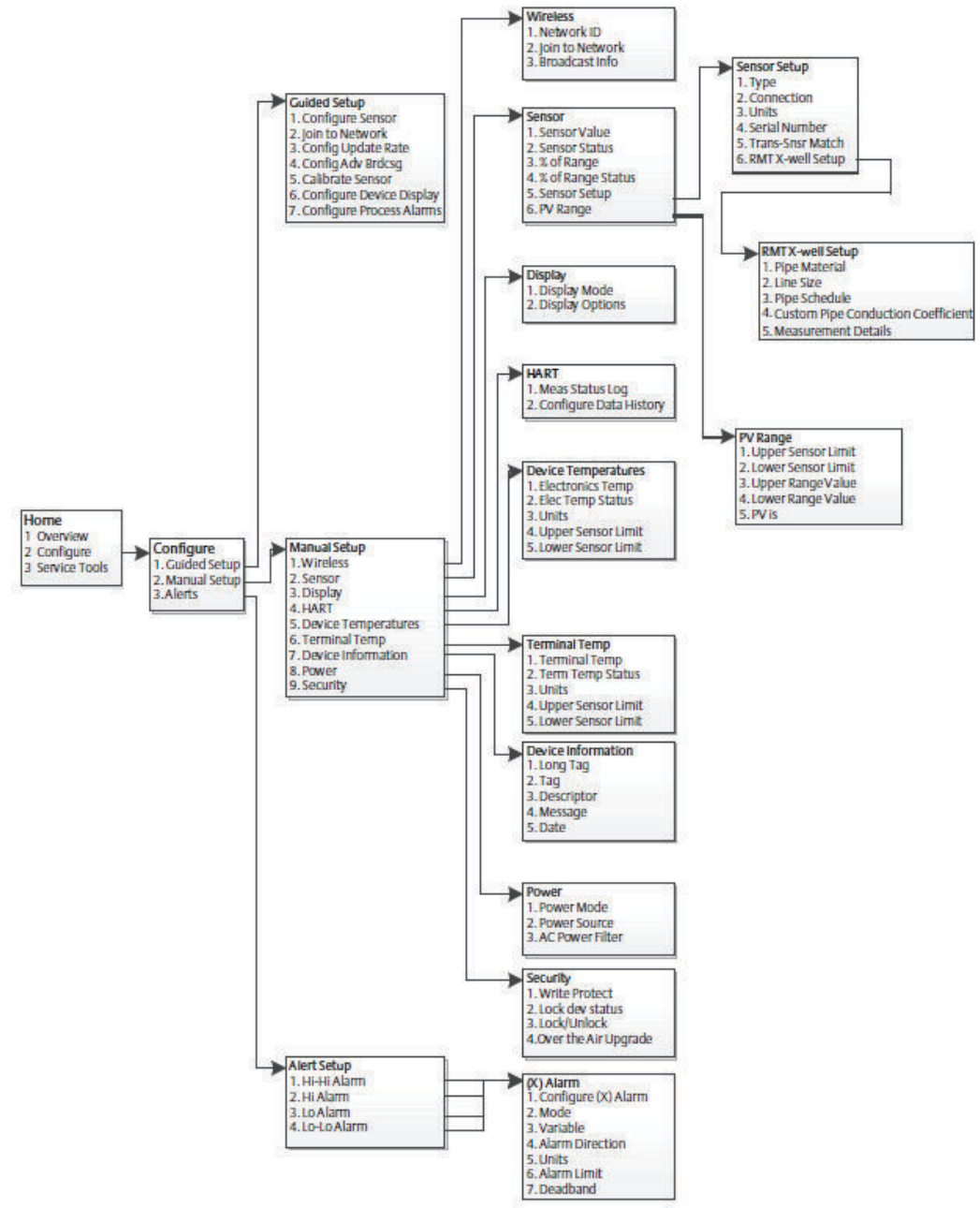
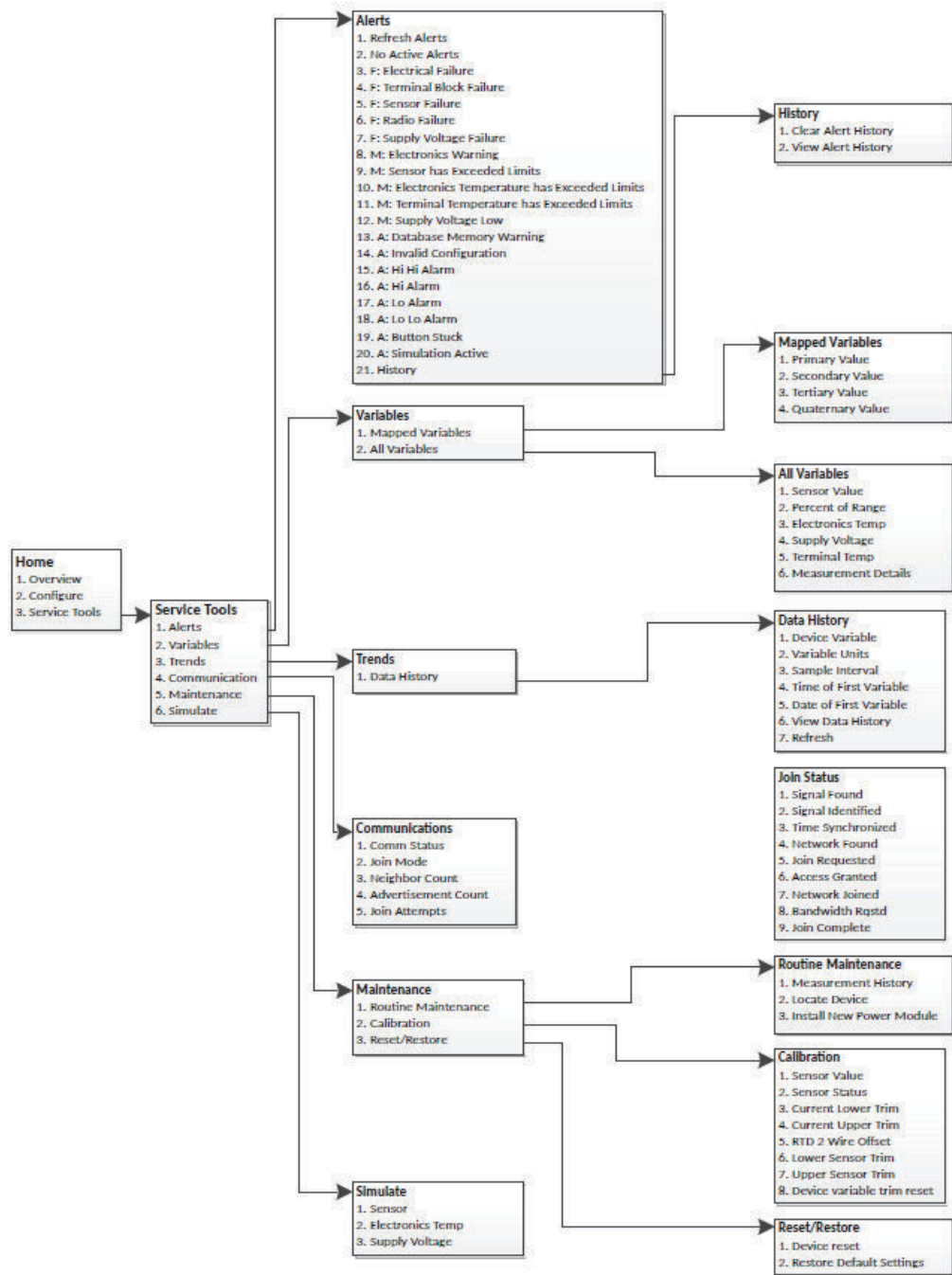

Figure 2-10: Service Tools



2.6 Fast Key sequence

Table 2-2 lists the Fast Key sequences for common transmitter functions.

Note

The Fast Key sequences assumes that the latest Device Dashboard (DD) is being used. The latest DD revision can be found on the title page of this document.

Table 2-2: Rosemount 648 Wireless Fast Key Sequence

Function	Fast Key sequence	Menu items
Device Information	2, 2, 7	Tag, Long Tag, Descriptor, Message, Date
Guided Setup	2, 1	Configure Sensor, Join to Network, Config Advance Broadcasting, Calibrate Sensor
Manual Setup	2, 2	Wireless, Sensor, Display, HART, Device Temperature, Terminal Temperature, Device Information, Power, Security
Wireless Configuration	2, 2, 1	Network ID, Join to Network, Broadcast Info
Sensor Configuration	2, 2, 2, 5	Type, Connection, Units, Serial Number, Transmitter-Sensor Matching, RMT X-well Setup
Sensor Calibration	3, 5, 2	Sensor Value, Sensor Status, Current Lower Trim, Current Upper Trim, RTD 2 Wire Offset, Lower Sensor Trim, Upper Sensor Trim, Device variable trim reset

2.7 Basic setup

2.7.1 Configure sensor type

Fast Keys	2, 1, 1
-----------	---------

Every temperature sensor has unique characteristics to achieve the most accurate measurement. Configure the wireless transmitter to match the specific sensor type.

Procedure

1. From the *Home* screen, select **2: Configure**.
2. Select **1: Guided Setup**
3. Select **1: Configure Sensor**, then follow on the on-screen instructions to complete the configuration.

This method allows selection of the number of lead wires and temperature engineering units for the sensor.

2.7.2 Join device to network

Fast key	2, 1, 2
----------	---------

To communicate with the Wireless Gateway, and ultimately the host system, the transmitter must be configured to communicate over the wireless network. This step is the wireless equivalent of connecting wires from a transmitter to the host system.

Procedure

1. From the **Home** screen, select **2: Configure**.
2. Select **1: Guided Setup**.
3. Select **2: Join to Network**.
4. Using a Field Communicator or AMS Device Manager to communicate with the transmitter, enter the Network ID and Join Key so they match the Network ID and Join Key of the Wireless Gateway and the other devices in the network.

Note

If the Network ID and Join Key are not identical to those set in the Gateway, the transmitter will not communicate with the network. The Network ID and Join Key may be obtained from the Wireless Gateway on the **System Settings** → **Network** → **Network Settings** page of the Wireless Gateway web based user interface.

Figure 2-11: Wireless Gateway Network Settings Page

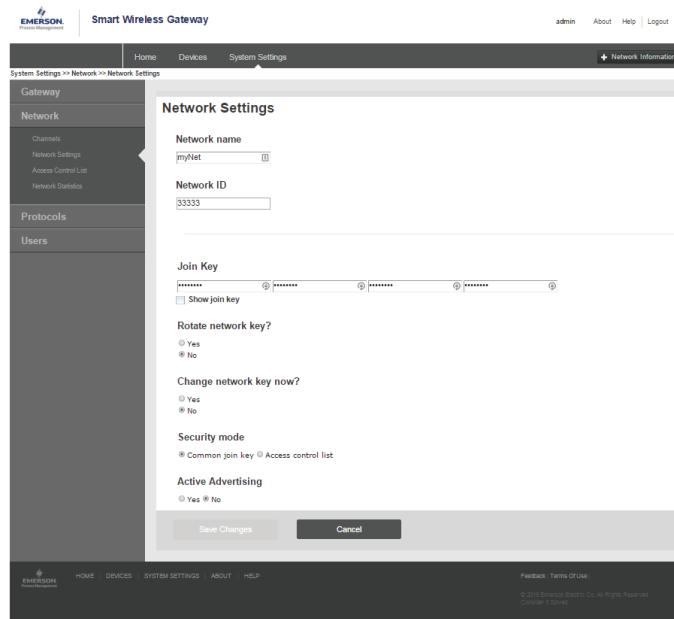

2.7.3 Configure update rate

Fast Keys	2, 1, 3
-----------	---------

The Update Rate is the frequency at which a new measurement is taken and transmitted over the wireless network. This by default is one minute. This may be changed at commissioning, or at any time via AMS Device Manager. The update rate is user selectable from one second to 60 minutes.

Procedure

1. From the *Home* screen, select **2: Configure**.
2. Select **1: Guided Setup**.
3. Select **3: Configure Update Rate**.
4. When the device configuration is completed, remove the power module and replace the module cover.

Postrequisites

NOTICE

The power module should be inserted only when the device is ready to be commissioned. Use caution when handling the power module.

Figure 2-12: Terminal Block

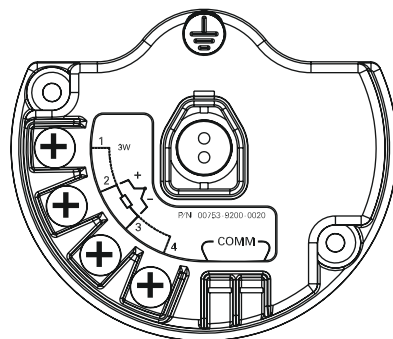

Connect the HART® Communication leads to the COMM terminals on the terminal block.

Figure 2-13: Field Communicator Connections

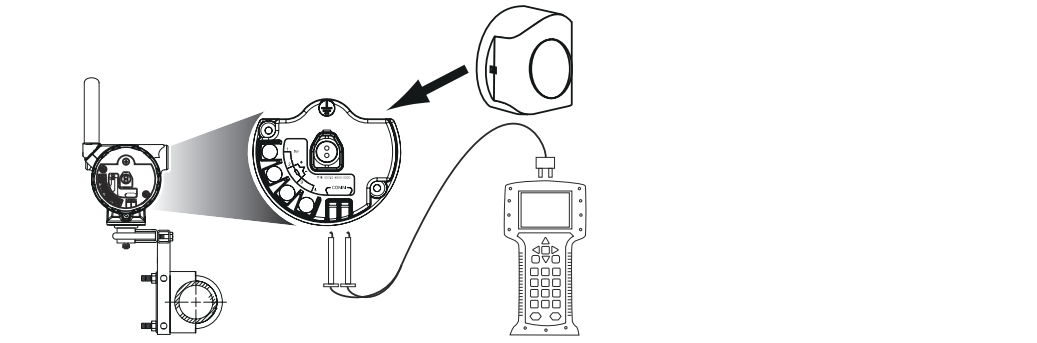

2.8 Calibration

Calibrating the transmitter increases the measurement precision by allowing corrections to be made to the factory-stored characterization curve by digitally altering the transmitter's interpretation of the sensor input.

To understand calibration, it is necessary to understand that smart transmitters operate differently from analog transmitters. An important difference is that transmitters are factory-characterized, meaning that they are shipped with a standard sensor curve stored in the transmitter firmware. In operation, the transmitter uses this information to produce a process variable output, in engineering units, dependent on the sensor input.

Calibration of the wireless transmitter may include the following procedures:

Sensor input trim:	Digitally alter the transmitter's interpretation of the input signal
Transmitter-sensor matching:	Generates a special custom curve to match that specific sensor curve, as derived from the Callendar-Van Dusen constants.

2.8.1 Sensor input trim

Fast Key sequence	3, 5, 2
-------------------	---------

Perform a sensor trim if the transmitters digital value for the primary variable does not match the plant's standard calibration equipment. The sensor trim function calibrates the sensor to the transmitter in temperature units or raw units. Unless your site-standard input source is NIST-traceable, the trim functions will not maintain the NIST-traceability of the system.

The Sensor Input Trim command allows the transmitter's interpretation of the input signal to be digitally altered. The sensor reference command trims, in engineering ($^{\circ}\text{F}$, $^{\circ}\text{C}$, $^{\circ}\text{R}$, K) or raw (Ω , mV) units, the combined sensor and transmitter system to a site standard using a known temperature source. Sensor trimming is suitable for validation procedures or for applications that require calibrating the sensor and transmitter together.

Procedure

1. Connect the calibration device or sensor to the transmitter. Refer to [Figure 2-1](#) on page 9 or on the device terminal block for sensor wiring diagrams.
2. Connect the communicator to the transmitter.
3. From the **Home** screen, select **3 Service Tools** → **5 Maintenance** → **2 Calibration** to prepare to trim the sensor.
4. Select **6 Lower Sensor Trim** or **7 Upper Sensor Trim**.

Note

It is recommended to perform lower offset trims first, before performing upper slope trims.

5. Answer the question about using an active calibrator or not.
6. Adjust the calibration device to the desired trim value (must be within the selected sensor limits). If a combined sensor and transmitter system are being trimmed, expose the sensor to a known temperature and allow the temperature reading to stabilize. Use a bath, furnace or isothermal block, measured with a site-standard thermometer, as the known temperature source.
7. Select **OK** once the temperature stabilizes. The communicator displays the output value the transmitter associates with the input value provided by the calibration device.
8. Select the appropriate sensor trim units at the prompt.
9. Enter the trim point.

2.8.2 Transmitter-sensor matching

Fast Key sequence	2, 1, 1
-------------------	---------

Perform the transmitter-sensor matching procedure to enhance the temperature measurement accuracy of the system (see the comparison below) and if you have a sensor with Callendar-Van Dusen constants. When ordered from Emerson, sensors with Callendar-Van Dusen constants are NIST-traceable.

The wireless transmitter accepts Callendar-Van Dusen constants from a calibrated RTD schedule and generates the actual curve to match that specific sensor curve.

Figure 2-14: Standard vs. Actual Sensor Curve

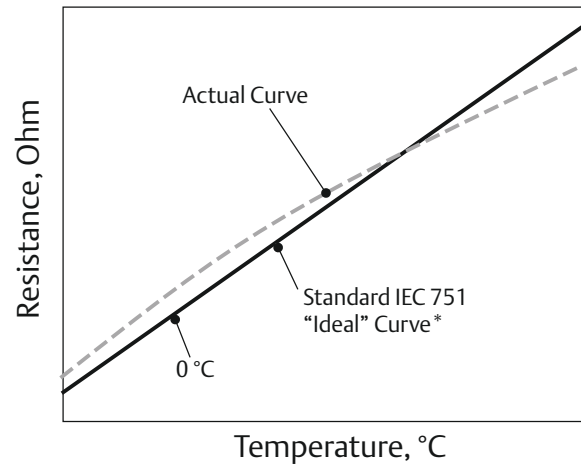

*The Actual Curve is identified from the Callendar-Van Dusen equation.

System accuracy comparison at 150 °C using a PT 100 (A=0.00385) RTD with a span of 0 to 200 °C			
Standard RTD		Matched RTD	
Rosemount 648 Wireless	±0.45 °C	Rosemount 648 Wireless	±0.45 °C
Standard RTD	±1.05 °C	Matched RTD	±0.18 °C
Total System ⁽¹⁾	±1.14 °C	Total System ⁽¹⁾	±0.48 °C

(1) Calculated using root-summed-squared (RSS) statistical method.

Total system accuracy = (Transmitter accuracy)² + (Sensor accuracy)²

Callendar-Van Dusen equation

$$R_t = R_0 + R_{0\alpha} [t - \delta(0.01t-1)(0.01t) - \beta(0.01t - 1)(0.01t)^3]$$

The following input variables, included with specially-ordered Rosemount temperature sensors, are required:

R_0 = Resistance at Ice Point Alpha = Sensor Specific Constant Beta = Sensor Specific Constant Delta = Sensor Specific Constant

To input Callendar-Van Dusen constants, perform the following procedure:

Procedure

1. From the **Home** screen, select **2 Configure** → **1 Guided Setup** → **1 Configure Sensor** → **1 Configure Type and Units** and press **Enter**.
2. Select **Cal VanDusen** at the **Select Sensor Type** prompt.
3. Select the appropriate number of wires at the **Select Sensor Connection** prompt.
4. Enter the R_0 , Alpha, Delta, and Beta values from the stainless steel tag attached to the special-order sensor when prompted.
5. Select desired other options and select **Enter**.

6. To disable the Transmitter-sensor matching feature from the **Home** screen select **Configure** → **Guided Setup** → **Configure Sensor** → **Configure Sensor Type and Units** and press **Enter**. Select the appropriate sensor type from the **Select Sensor type** prompt.

Note

When the transmitter-sensor matching is disabled, the transmitter reverts to factory trim. Ensure the transmitter engineering units default correctly before placing the transmitter into service.

2.9 Advanced setup

2.9.1 LCD display

The LCD display configuration command allows customization of the LCD display to suit application requirements. The LCD display will alternate between the selected items:

- Temperature units
- Sensor temperature
- % of range
- Supply voltage

Reference [LCD display screen messages](#) for images of LCD display screens.

Configuring LCD display with Field Communicator

Fast Keys	2, 1, 6
-----------	---------

Transmitter ordered with the LCD display will be shipped with display installed and enabled.

If the transmitter was ordered without the LCD display or if the LCD display was disabled, follow these steps to enable the LCD display on the transmitter.

Procedure

1. From the *Home* screen, select **2: Configure**.
2. Select **1: Guided Setup**.
3. Select **6: Configure Device Display**.
4. Select the **Periodic** option.
5. Select desired display options and select **Enter**.

Configuring LCD display with AMS Device Manager

Procedure

1. Right click on the device and select **Configure**.
2. Under *Optional Setup*, select **Configure Device Display** button.
3. Select desired display options and select **Enter**.

Note

The LCD display can be order as a spare part with part number: 00753-9004-0002.

2.9.2 Rosemount X-well technology

The Rosemount 648 Wireless can be ordered with Rosemount X-well technology via the “PT” model option code. The “C1” model option code must be ordered if the “PT” option

code is specified. The “C1” option code requires user supplied information of process pipe material and pipe schedule. Rosemount X-well technology can be configured with any asset management software that supports Electronic Device Description Language (EDDL). The Device Dashboard interface with DD revision 648 Dev. 4 Rev. 1 or higher is required to view Rosemount X-well functionality.

The “Rosemount X-well Process” sensor/type option should be selected as the sensor type in most cases. Once selected, pipe material, line size, and pipe schedule information is required when configuring Rosemount X-well technology. This section is referring to the process pipe properties that Rosemount 648 Wireless and 0085 Pipe Clamp Sensor with Rosemount X-well technology is going to be installed in. This information is required for the in-transmitter algorithm to accurately calculate process temperature.

In the rare case that the process pipe is not available, a custom value for the pipe conduction coefficient can be entered. This field becomes available when the “Rosemount X-well Custom” sensor/type option is selected.

Configure Rosemount X-well technology with Field Communicator

Procedure

1. From the *Home* screen, select **2: Configure**.
2. Select **1: Guided Setup**.
3. Select **1: Configure Sensor**.
4. Select **1: Configure Sensor Type and Units**.
5. Select either **Rosemount X-well Process** or **Rosemount X-well Custom**.
6. Select desired configurations and select **Enter**.

Configure Rosemount X-well technology with AMS Device Manager

Procedure

1. Right click on the device and select **Configure**.
2. In the menu tree, select **Manual Setup**.
3. Select the **Sensor** tab.
4. Select either **Rosemount X-well Process** or **Rosemount X-well Custom**.
5. Select desired configurations and select **Send**.

Figure 2-15: Manual Setup - Sensor Screen for the Rosemount 648 Wireless with Rosemount X-well Technology

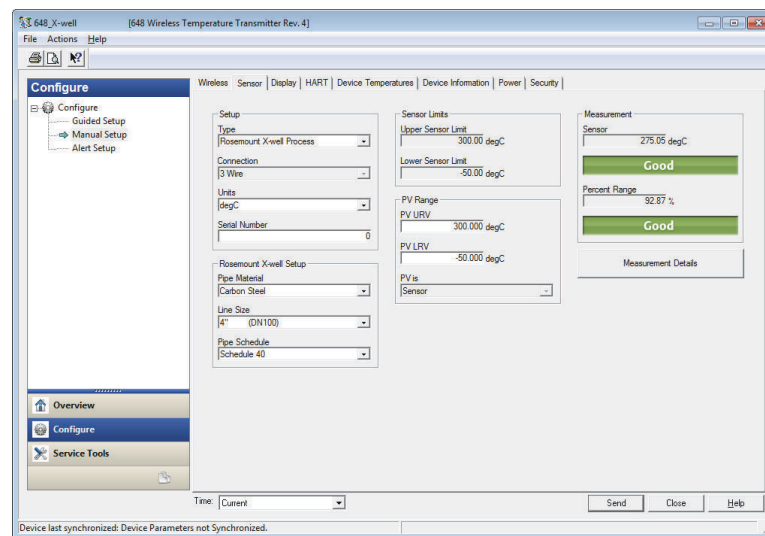

View Rosemount X-well measurement details

To view live data and trending for measured ambient temperature, measured surface temperature, and calculated process temperature, perform the following procedure:

Procedure

1. Right click on the device and select **Configure**.
2. In the menu tree, select **Manual Setup**.
3. Select the **Sensor** tab.
4. Select the **Measurement Details** button.

Figure 2-16: Rosemount X-well Measurement Details Page

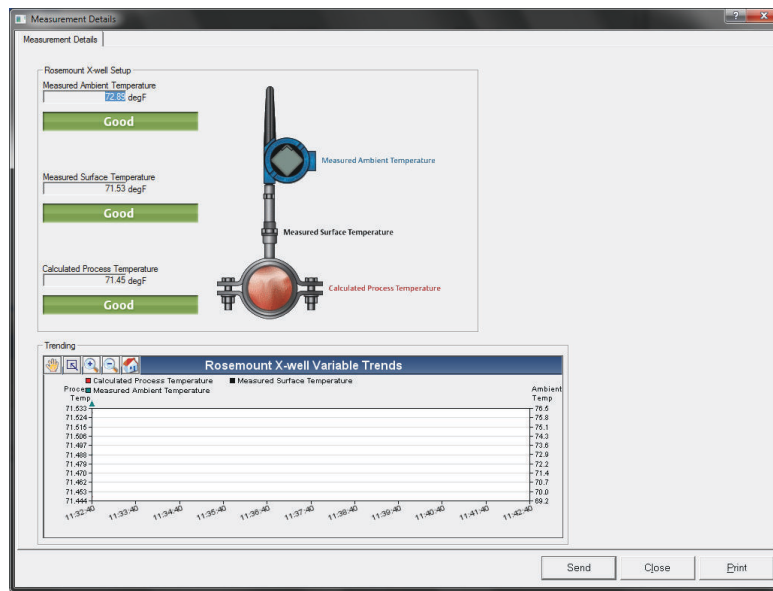

2.9.3 Process alerts

Fast Key sequence	2, 1, 7
-------------------	---------

Process alerts allow the user to configure the transmitter to output a HART message when the configured data point is exceeded. An alert will be transmitter continuously if the set points are exceeded and the alert mode is ON. An alert will be displayed on a Field Communicator, AMS Device Manager status screen or in the error section of the LCD display. The alert will reset once the value returns within range.

Note

HI alert value must be higher than the LO alert value. Both alert values must be within the temperature sensor limits.

Figure 2-17: Example 1: Rising Alert

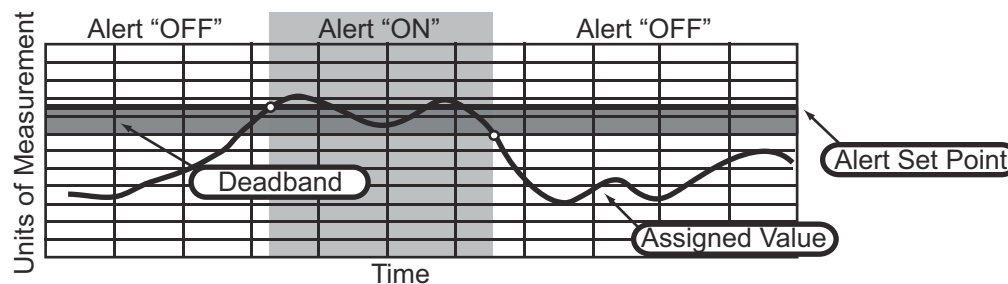
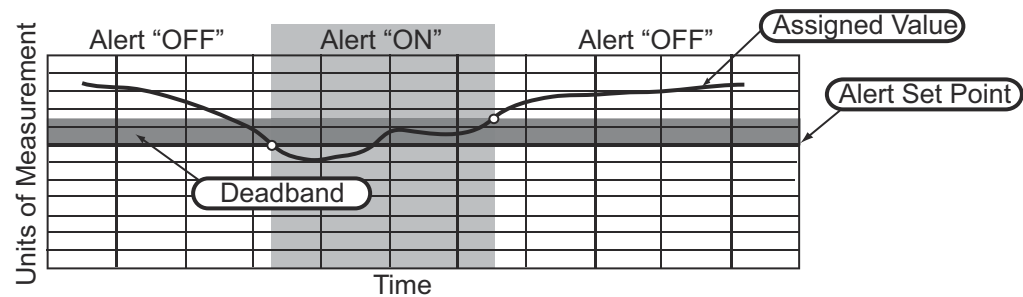

Figure 2-18: Example 2: Falling Alert



Field Communicator

To configure the process alerts with a Field Communicator, perform the following procedure:

Procedure

1. From the *HOME* screen, follow the Fast Key sequence, **2 Configure** → **1 Guided Setup** → **1 Guided Setup**.
2. Select **2 for Hi-Hi Alarm**, or Select **3 for Hi Alarm**, or Select **4 for LO Alarm**, or Select **5 for LO-LO Alarm** and press **Enter**.
3. If the alarm is disabled, select **1 Enable** and press **Enter**. If the alarm was previously enabled, select **2 Leave Enabled** and press **Enter**.
4. Enter the alarm limit and press **Enter**.
5. Enter the alarm deadband and press **Enter**.

2.10 Remove power module

After the sensor and network have been configured, remove the Power Module and replace the transmitter cover. The Power Module should be inserted only when the device is ready to be commissioned. Use caution when handling the Power Module. The Power Module may be damaged if dropped from heights in excess of 20 feet.

3 Installation

3.1 Overview

The information in this section covers installation considerations. Instructions on how to access Dimensional drawings for each Rosemount 648 Wireless variation and mounting configuration are included in Rosemount 648 Wireless [Product Data Sheet](#).

3.2 Safety messages

Instructions and procedures in this section may require special precautions to ensure the safety of the personnel performing the operations. Information that potentially raises safety issues is indicated by a warning symbol (⚠). Refer to the following safety messages before performing an operation preceded by this symbol.

⚠ WARNING

Follow instructions

Failure to follow these installation guidelines could result in death or serious injury.
Ensure only qualified personnel perform the installation.

Explosions

Explosions could result in death or serious injury.

Installation of this transmitter in an explosive environment must be in accordance with the appropriate local, national, and international standards, codes, and practices. Review the approvals section of this manual for any restrictions associated with a safe installation.

Before connecting a communicator in an explosive atmosphere, ensure the instruments in the segment are installed in accordance with intrinsically safe or non-incendive field wiring practices.

Process leaks

Process leaks could result in death or serious injury.
Install and tighten process connectors before applying pressure.

Electrical shock

Electrical shock could cause death or serious injury.
Avoid contact with the leads and terminals. High voltage that may be present on leads can cause electrical shock.

⚠ WARNING

This device complies with Part 15 of the FCC Rules. Operation is subject to the following conditions:

This device may not cause harmful interference.

This device must accept any interference received, including interference that may cause undesired operation.

This device must be installed to ensure a minimum antenna separation distance of 8-in. (20 cm) from all persons.

The power module may be replaced in a hazardous area. The power module has surface resistivity greater than one gigaohm and must be properly installed in the wireless device enclosure. Care must be taken during transportation to and from the point of installation to prevent electrostatic charge build-up.

Physical access

Unauthorized personnel may potentially cause significant damage to and/or misconfiguration of end users' equipment. This could be intentional or unintentional and needs to be protected against.

Physical security is an important part of any security program and fundamental to protecting your system. Restrict physical access by unauthorized personnel to protect end users' assets. This is true for all systems used within the facility.

3.3 Wireless considerations

3.3.1 Power up sequence

The Rosemount 648 Wireless and all other wireless devices should be installed only after the Wireless Gateway ("Gateway") has been installed and is functioning properly. Wireless devices should also be powered up in order of proximity from the Gateway, beginning with the closest. This will result in a simpler and faster network installation. Enable active advertising on the Gateway to ensure new devices join the network faster. For more information, see the Wireless Gateway [Reference Manual](#).

3.3.2 Antenna position

The antenna should be positioned vertically, either straight up or straight down, and it should be approximately 3 ft. (1 m) from any large structure, building, or conductive surface to allow for clear communication to other devices.

Figure 3-1: Antenna Position

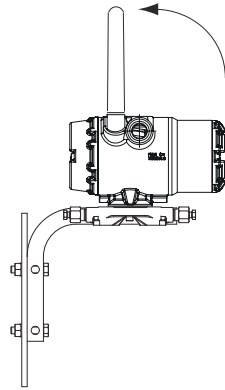

3.3.3 Conduit entry

Upon installation, ensure each conduit entry is either sealed with a conduit plug using approved thread sealant, or has an installed conduit fitting or cable gland with appropriate threaded sealant.

Note

The conduit entries on the Emerson 781 Field Link are threaded $\frac{1}{2}$ -14 NPT.

Figure 3-2: Conduit Entry

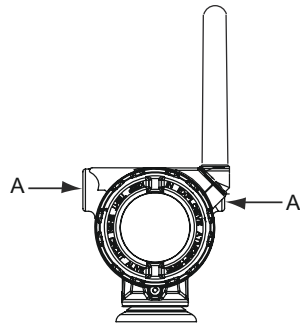

A. Conduit entry

3.3.4 Field Communicator connections

The Black Power Module needs to be installed in the device for the Field Communicator to interface with the Rosemount 648 Wireless. For HART Wireless Transmitter communication via a Field Communicator, a Rosemount 648 Wireless Device Dashboard (DD) is required. Rosemount 648 Wireless Transmitters equipped with Rosemount X-well Technology requires DD revision 648 Dev. 4 Rev. 1 or higher to view Rosemount X-well functionality. To obtain the latest DD, visit the Field Communicator System Software and Device Description site at: [Emerson.com/Field-Communicator](https://www.emerson.com/Field-Communicator)

Refer to [Figure 3-3](#) for instructions on connecting the Field Communicator to the Rosemount 648 Wireless Transmitter.

Figure 3-3: Connection

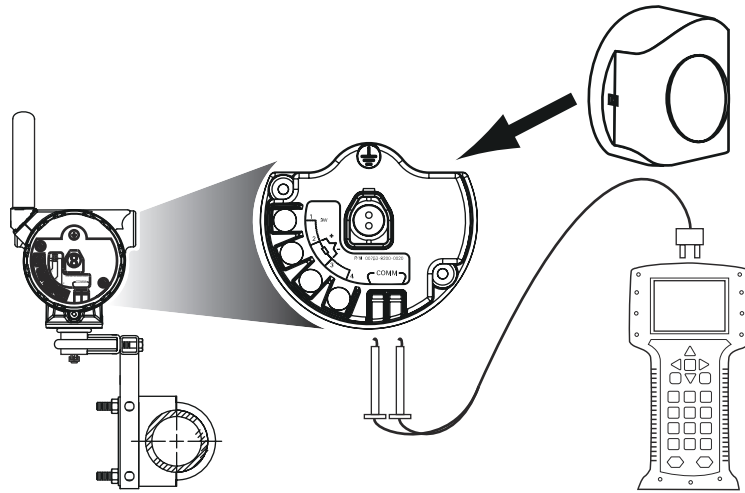

3.4 Physical installation

3.4.1 Transmitter installation

The transmitter can be installed in one of two configurations:

- Direct Mount, where the sensor is connected directly to the Rosemount 648 Wireless housing's conduit entry.
- Remote Mount, where the sensor is mounted separate from the Rosemount 648 Wireless housing, then connected to the transmitter using conduit.

Select the installation sequence that corresponds to the mounting configuration.

3.4.2 Direct mount

The direct mount installation should not be used when installing with a Swagelok® fitting.

Procedure

1. Install sensor according to standard installation practices using approved thread sealant on all connections.
2. Attach transmitter housing to the sensor using the threaded conduit entry.
3. Attach sensor wiring to the terminals as indicated on the wiring diagram.
4. Connect Black Power Module.

Note

Wireless devices should be powered up in order of proximity from the Wireless Gateway, beginning with the closest device to the gateway. This will result in a simpler and faster network installation.

Figure 3-4: Installing Electronics Housing Cover

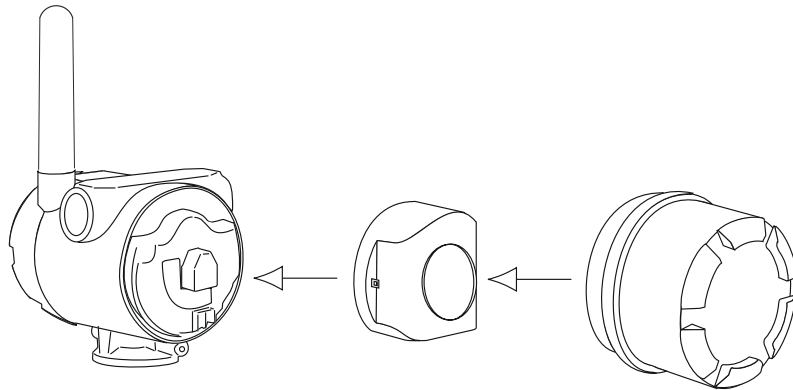

5. Close housing cover and tighten to safety specification. Always ensure a proper seal by installing the electronics housing covers so metal touches metal, but do not over tighten.
6. Position antenna vertically, either straight up or straight down. The antenna should be approximately 3 ft. (1 m) from any large structures or buildings, to allow clear communication to other devices.

Figure 3-5: Possible Antenna Rotation

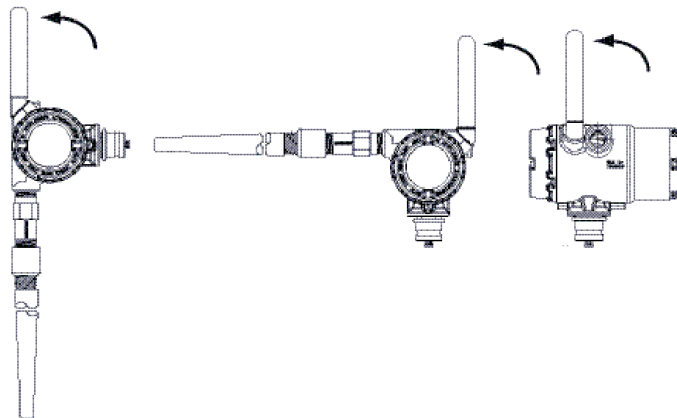

3.4.3 Remote mount

Procedure

1. Install sensor according to standard installation practices using an approved thread sealant on all connections.
2. Run wiring (and conduit, if necessary) from the sensor to the transmitter.
3. Pull wiring through the threaded conduit entry of the transmitter.
4. Attach sensor wiring to the terminals as indicated on the wiring diagram.
5. Connect Black Power Module.

Note

Wireless devices should be powered up in order of proximity from the wireless gateway, beginning with the closest device to the Gateway. This will result in a simpler and faster network installation.

Figure 3-6: Installing Electronics Housing Cover

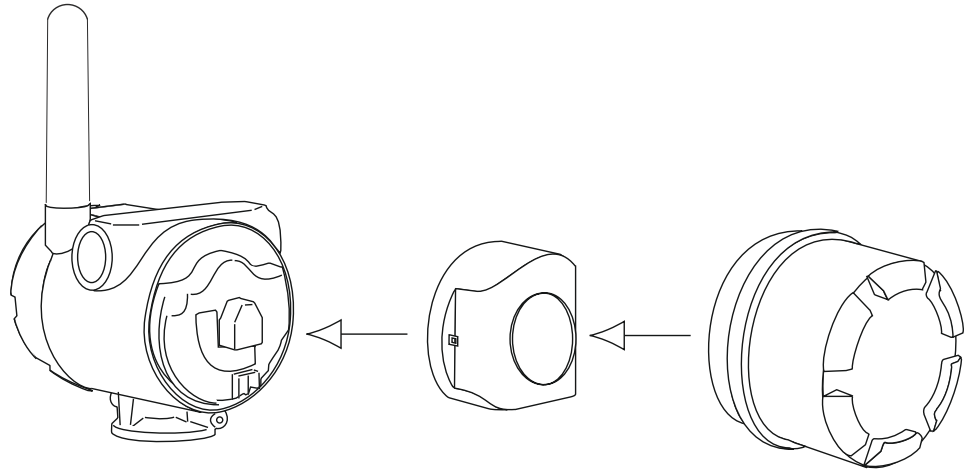

6. Close housing cover and tighten to safety specification. Always ensure a proper seal by installing the electronics housing covers so metal touches metal, but do not over tighten.
 7. Position antenna vertically, either straight up or straight down. The antenna should be approximately 3 ft. (1 m) from any large structures or buildings to allow clear communication to other devices.
-

Figure 3-7: Possible Antenna Rotation

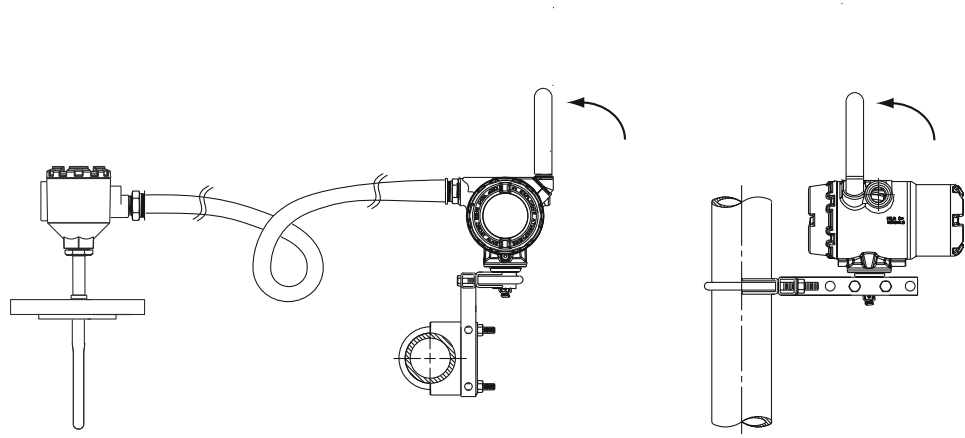

3.4.4 Rosemount X-well Installation

Rosemount X-well Technology is only available in the Rosemount 648 Wireless and 0085 pipe clamp sensor factory assembled complete point solution. Rosemount X-well Technology will only work as specified with factory supplied and assembled pipe clamp sensor.

In general, pipe clamp sensor installation best practices shall be followed (see Rosemount 0085 Pipe Clamp Sensor [Reference Manual](#)) with Rosemount X-well Technology specific requirements noted below:

Procedure

1. Direct mounting of transmitter on pipe clamp sensor is required for Rosemount X-well Technology to properly function.
2. Transmitter head shall be placed away from dynamic external temperature sources such as a boiler.
3. Insulation (½-in. thick minimum) is required over the sensor clamp assembly and sensor extension up to transmitter head to prevent heat loss. Apply a minimum of six inches of insulation on each side of the pipe clamp sensor. Care should be taken to minimize air gaps between insulation and pipe. See [Figure 3-8](#).

Note

DO NOT apply insulation over transmitter head.

4. Although it will come factory configured as such, ensure that pipe clamp RTD sensor is assembled in 3-wire configuration. See [#unique_14/unique_14_Connect_42_section_rkb_bb1_qkb](#) for more information.
-

Figure 3-8: Rosemount 648 Wireless with Rosemount X-well Technology Installation Drawing

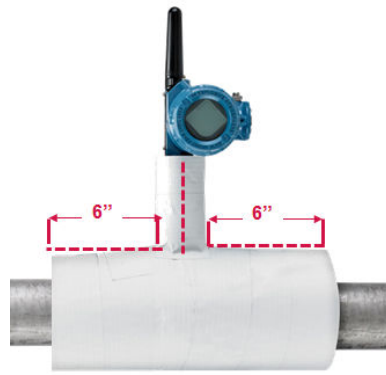

3.4.5 LCD display

Transmitters ordered with the optional LCD display will be shipped with the display installed. The LCD display can be rotated in 90 degree increments by squeezing the two tabs, pulling out, rotating and snapping back into place. If LCD display pins are inadvertently removed from the interface board, carefully re-insert the pins before snapping the LCD display back into place.

Procedure

1. Remove the LCD display cover. Do not remove the instrument covers in explosive environments when the circuit is live.
2. Put the 4-pin connector into the LCD display, rotate to the desired position and snap into place.
3. Replace the transmitter cover.

The following LCD display temperature limits:

- Operating: -4 to 175 °F (-20 to 80 °C)
- Storage: -40 to 185 °F (-40 to 85 °C)

Note

Only use Rosemount Wireless LCD Display part number: 00753-9004-0002.

Figure 3-9: Optional LCD Display

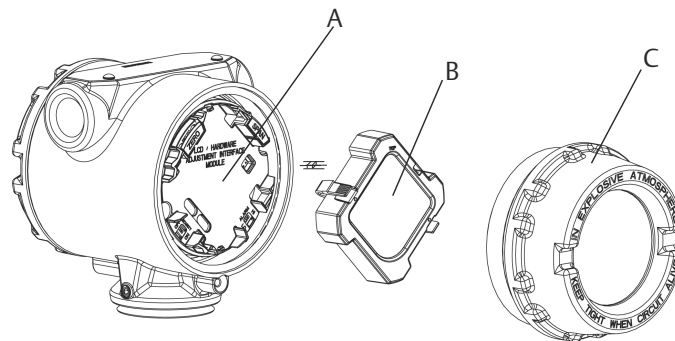

- A. LCD display pins
 - B. LCD display display
 - C. LCD display cover
-

3.5 Ground the transmitter

The transmitter will operate with the housing either floating or grounded. However, the extra noise in floating systems affects many types of readout devices. If the signal appears noisy or erratic, grounding the transmitter at a single point may solve the problem.

The electronics enclosure should be grounded in accordance with local and national installation codes. This can be accomplished via the process connection, via the internal case grounding terminal, or via the external grounding terminal.

3.5.1 Thermocouple, mV, and RTD/Ohm inputs

Each process installation has different requirements for grounding. Use the grounding options recommended by the facility for the specific sensor type, or begin with grounding Option 1 (the most common).

Option 1

Procedure

1. Connect sensor wiring shield to the transmitter housing (only if the housing is grounded)
2. Ensure the transmitter housing is electrically isolated from the sensor wiring.

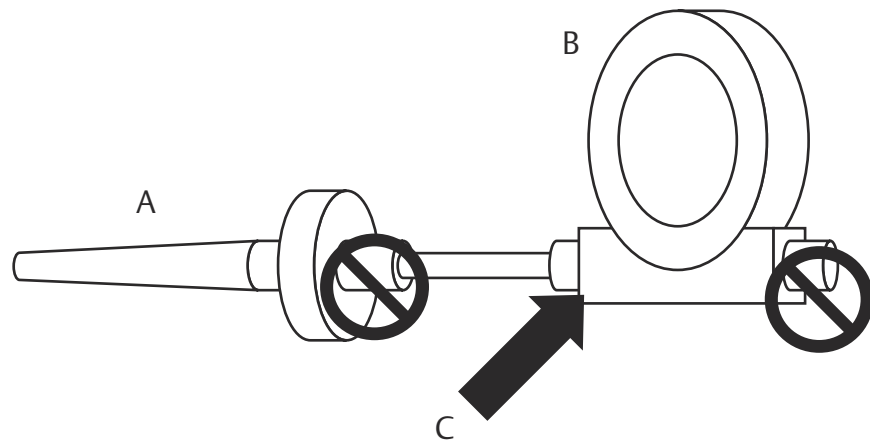

- A. Sensor wires
- B. Transmitter
- C. Shield ground point

Option 2

Procedure

1. Ground sensor wiring shield at the sensor.
2. Ensure the sensor wiring and shield is electrically isolated from the transmitter housing.

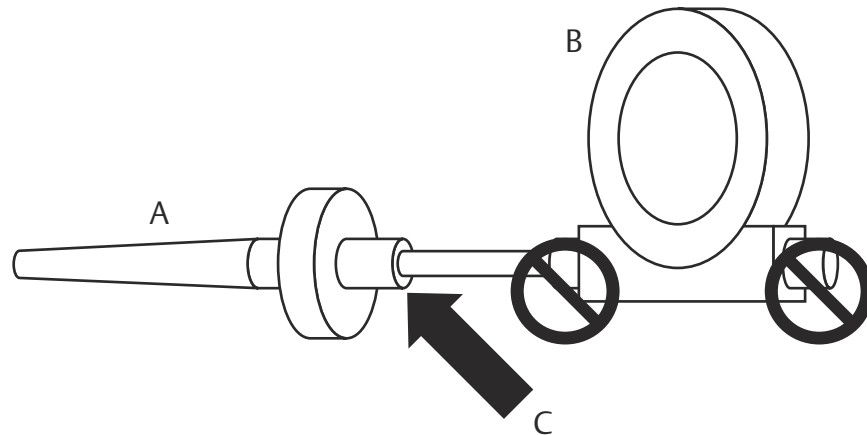

- A. Sensor wires
- B. Transmitter
- C. Shield ground point

Note

Always use facility recommended wiring practices.

3.6 Fast Key sequence

Table 3-1 lists the Fast Key sequences for common transmitter functions.

Table 3-1: Fast Key Sequence

Function	Fast Key sequence	Menu items
Device Information	2, 2, 7	Tag, Long Tag, Descriptor, Message, Date
Guided Setup	2, 1	Configure Sensor, Join to Network, Config Advance Broadcasting, Calibrate Sensor
Manual Setup	2, 2	Wireless, Sensor, Display, HART, Device Temperature, Terminal Temp, Device Information, Power, Security
Wireless Configuration	2, 2, 1	Network ID, Join to Network, Broadcast Info
Sensor Configuration	2, 2, 2, 5	Type, Connection, Units, Serial Number, Transmitter-Sensor Matching, RMT X-well Setup
Sensor Calibration	3, 5, 2	Sensor Value, Sensor Status, Current Lower Trim, Current Upper Trim, RTD 2 Wire Offset, Lower Sensor Trim, Upper Sensor Trim, Device variable trim reset

4 Commissioning

4.1 Overview

The information in this section contains techniques to properly commissioning the device. A Rosemount 648 [Quick Start Guide](#) is shipped with every transmitter to describe basic installation and startup procedures.

4.2 Safety messages

Instructions and procedures in this section may require special precautions to ensure the safety of the personnel performing the operations. Information that potentially raises safety issues is indicated by a warning symbol (⚠). Refer to the following safety messages before performing an operation preceded by this symbol.

⚠ WARNING

Follow instructions

Failure to follow these installation guidelines could result in death or serious injury.
Ensure only qualified personnel perform the installation.

Explosions

Explosions could result in death or serious injury.

Installation of this transmitter in an explosive environment must be in accordance with the appropriate local, national, and international standards, codes, and practices. Review the approvals section of this manual for any restrictions associated with a safe installation.

Before connecting a communicator in an explosive atmosphere, ensure the instruments in the segment are installed in accordance with intrinsically safe or non-incendive field wiring practices.

Process leaks

Process leaks could result in death or serious injury.
Install and tighten process connectors before applying pressure.

Electrical shock

Electrical shock could cause death or serious injury.
Avoid contact with the leads and terminals. High voltage that may be present on leads can cause electrical shock.

⚠ WARNING

This device complies with Part 15 of the FCC Rules. Operation is subject to the following conditions:

This device may not cause harmful interference.

This device must accept any interference received, including interference that may cause undesired operation.

This device must be installed to ensure a minimum antenna separation distance of 8-in. (20 cm) from all persons.

The power module may be replaced in a hazardous area. The power module has surface resistivity greater than one gigaohm and must be properly installed in the wireless device enclosure. Care must be taken during transportation to and from the point of installation to prevent electrostatic charge build-up.

Physical access

Unauthorized personnel may potentially cause significant damage to and/or misconfiguration of end users' equipment. This could be intentional or unintentional and needs to be protected against.

Physical security is an important part of any security program and fundamental to protecting your system. Restrict physical access by unauthorized personnel to protect end users' assets. This is true for all systems used within the facility.

4.3 Verify operation

The transmitter can be commissioned before or after installation. It may be useful to commission it on the bench, before installation, to ensure proper operation and to become familiar with its functionality. When applicable, make sure the instruments are installed in accordance with intrinsically safe or non-incendive field wiring practices. The device will be powered whenever the power module is installed. To avoid depleting the power module, make sure it is removed when the device is not in use.

Operation can be verified in four locations: at the device via the LCD display, using a Field Communicator, the Wireless Gateway's integrated web interface, or using AMS Suite Wireless Communicator or AMS Device Manager.

4.3.1 LCD display

During normal operation, the LCD display will display the PV value at the wireless transmit rate up to as fast as one minute intervals. Refer to [LCD display screen messages](#) for error codes and other LCD display messages. Press the Diagnostic button to display the TAG, Device ID, Network ID, Network Join Status and Device Status screens. For Device Status screens, see .

Figure 4-1: Diagnostic Screen Sequence

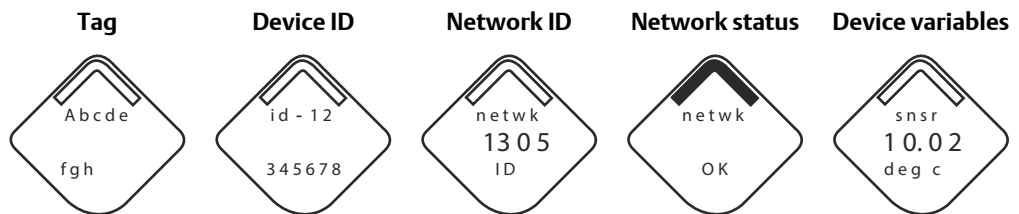
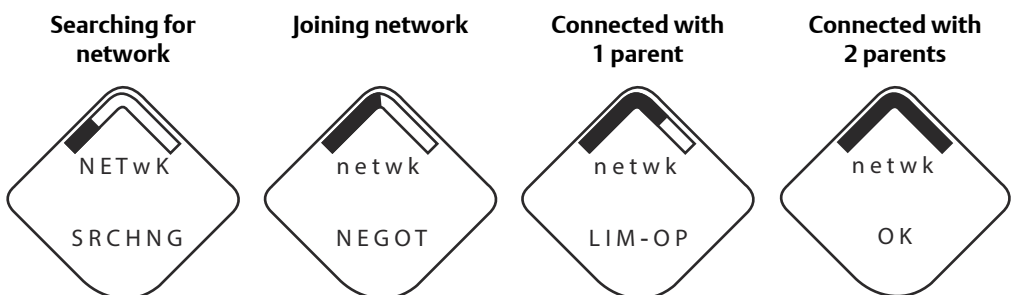

Figure 4-2: Network Status Screens



4.3.2 Field Communicator

For HART Wireless transmitter communication via a Field Communicator, a Rosemount 648 Wireless Device Dashboard (DD) is required. Rosemount 648 Wireless Transmitter equipped with Rosemount X-well Technology requires DD revision 648 Dev. 4 Rev. 1 or higher to view Rosemount X-well functionality. To obtain the latest DD, visit the Emerson.com/Field-Communicator.

The communication status may be verified in the wireless device using the following Fast Key sequence.

Function	Fast Key sequence	Menu items
Communication	3, 4	Comm, Join Mode, Neighbor Count, Advertisement Count, Join Attempts

4.3.3 Wireless Gateway

If the Rosemount 648 Wireless was configured with the Network ID and Join Key and sufficient time for network polling has passed, the transmitter will be connected to the network. To verify device operation and connectivity using the Wireless Gateway's web based user interface, navigate to the Devices page. This page will also display the transmitter's tag, PV, SV, TV, QV, and Last Update time. Refer to Emerson Wireless Gateway [Manual Supplement](#) for terms, user fields, and parameters used in the Wireless Gateway web based user interface.

Note

The time to join the new device(s) to the network is dependent upon the number of devices being joined and the number of devices in the current network. For one device joining an existing network with multiple devices, it may take up to five minutes. It may take up to 60 minutes for multiple new devices to join the existing network.

Figure 4-3: Wireless Gateway Devices Page

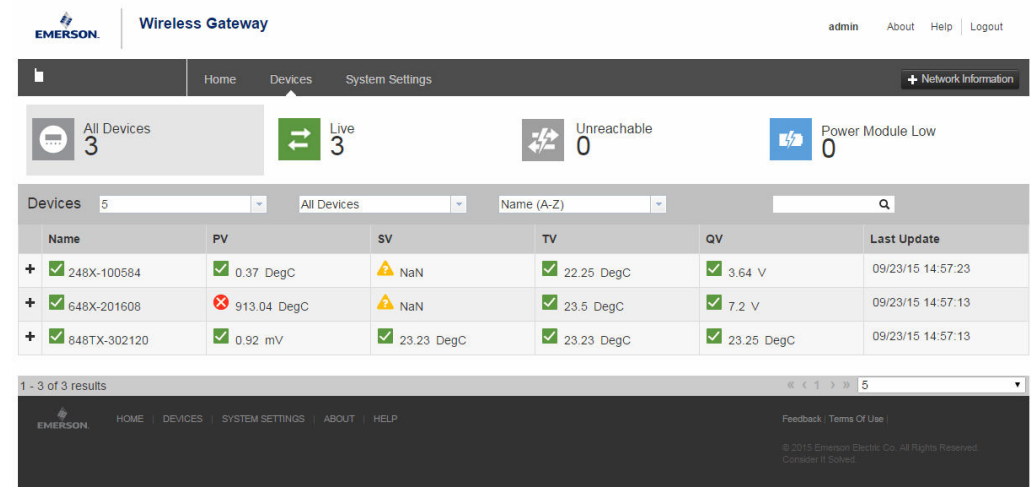

4.3.4 AMS Wireless Configurator

For HART Wireless transmitter communication via AMS Wireless Configurator, a Rosemount 648 Wireless Device Dashboard (DD) is required. Rosemount 648 Wireless Transmitters equipped with Rosemount X-well technology requires DD revision 648 Dev. 4 Rev. 1 or higher to view Rosemount X-well functionality. To obtain the latest DD, visit the Emerson.com/Field-Communicator.

Figure 4-4: AMS Wireless Configurator Explorer Window

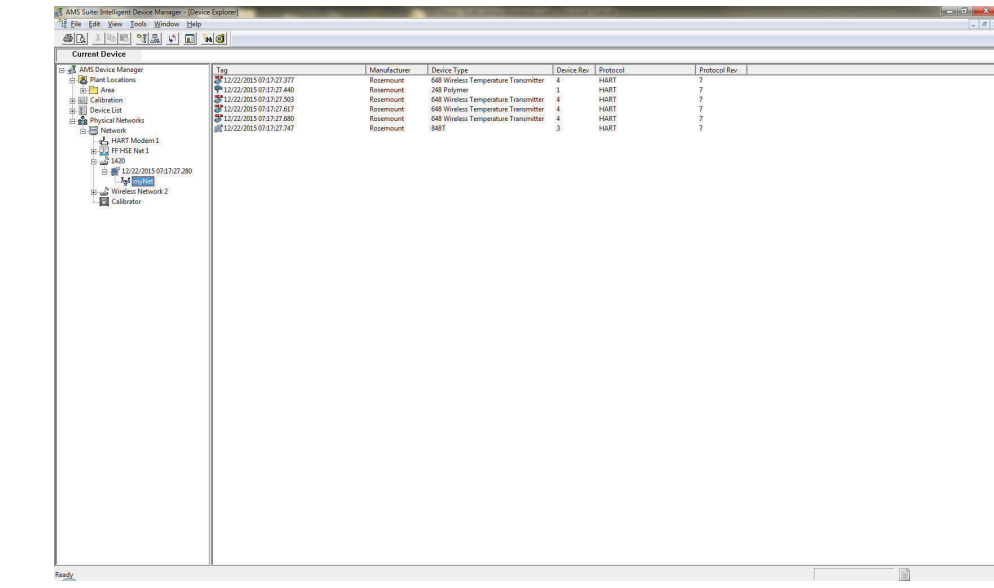



5 Operation and maintenance

5.1 LCD display screen messages

5.1.1 Startup screen sequence

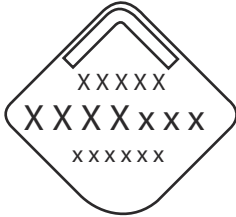
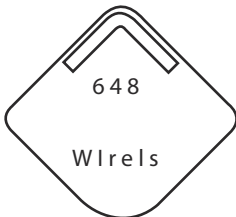
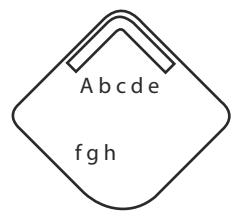
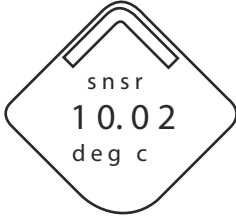
The following screens will display when the power module is first connected to the Rosemount™ 648 Wireless Temperature Transmitter.

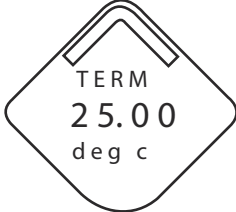
	<p>All Segments On: used to visually determine if there are any bad segments on the LCD display</p>
	<p>Device Identification: used to determine Device Type</p>
	<p>Device Information - Tag: user entered tag which is eight characters long - will not display if all characters are blank</p>
	<p>PV Screen: process temperature, ohms or mV value depending on how the device is configured</p>

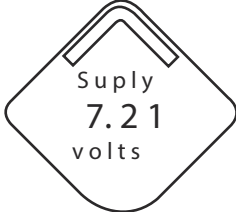
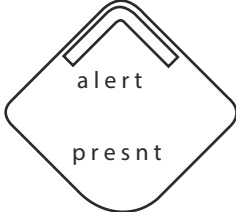
 <p>TERM 25.00 deg c</p>	<p>SV Screen: terminal temperature value</p>
 <p>DEV 25.25 deg c</p>	<p>TV Screen: feature board temperature value</p>
 <p>Suply 7.21 volts</p>	<p>QV Screen: voltage reading at the power module terminals</p>
 <p>alert presnt</p>	<p>Alert Screen: at least one alert is present - this screen will not display if no alerts are present</p>

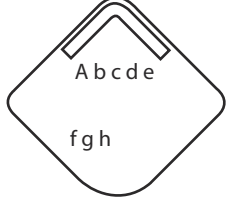
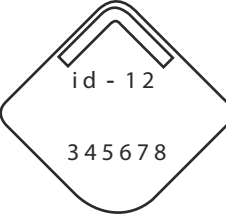
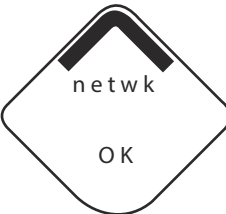
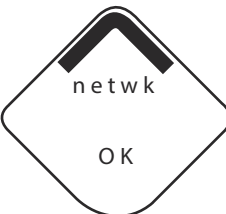
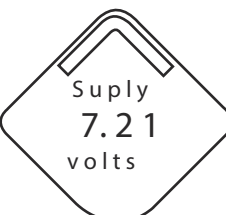

5.1.2 Diagnostic button screen sequence

The following five screens will display when the device is operating properly and the Diagnostic Button has been pressed.

	<p>Device Information - Tag: user entered tag which is 8 characters long - will not display if all characters are blank</p>
	<p>Device Identification: used to determine Device ID</p>
	<p>Diagnostic Button Screen 3: assuming the device has the correct join key, this ID tells the user what network the device can connect with</p>
	<p>Diagnostic Button Screen 4.11: the device has joined a network and has been fully configured and has multiple parents</p>
	<p>Diagnostic Button Screen 5: voltage reading at the power module terminals</p>

5.1.3 Network diagnostic status screens

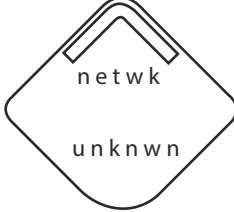
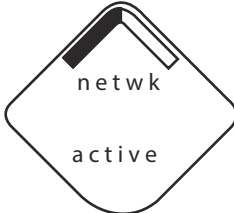

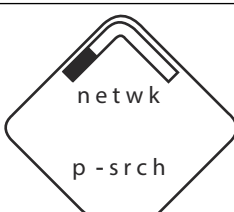

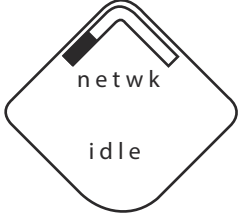
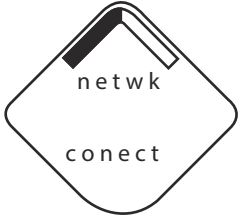
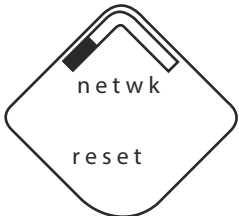
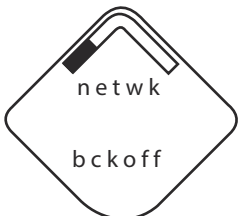
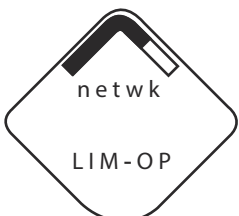
These screens display the network status of the device. Only one will be shown during the startup sequence or diagnostic sequence.

	<p>Diagnostic Button Screen 4.1: the device has yet to retrieve the information from the Smart Wireless Gateway and is still in the process of being activated</p>
	<p>Diagnostic Button Screen 4.2: the device has received the ACTIVATE command from the Smart Wireless Gateway, but is in the process of being configured to the wireless network</p>
	<p>Diagnostic Button Screen 4.3: the device has sent JOIN request and is waiting for the ACTIVATE command</p>
	<p>Diagnostic Button Screen 4.4: the device is in active search</p>
	<p>Diagnostic Button Screen 4.5: the device is in passive search</p>

	<p>Diagnostic Button Screen 4.6: the device couldn't find the network and is in deep sleep mode to preserve power module life</p>
	<p>Diagnostic Button Screen 4.7: the device synchronized to a network</p>
	<p>Diagnostic Button Screen 4.8: the device will reset</p>
	<p>Diagnostic Button Screen 4.9: the device couldn't join because of dropped packets and will reset</p>
	<p>Diagnostic Button Screen 4.10: the device has joined a network and has been fully configured but has only one parent device</p>

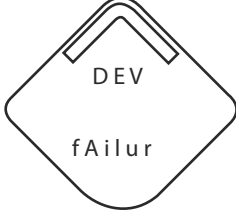
5.1.4 Device diagnostic screens

The following screens will show the device diagnostics depending on the state of the device.

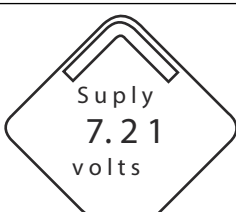
	<p>Device Information - Status: there is a critical error which may prevent the device from operating correctly. Check additional status screens for more information.</p>
	<p>PV Screen: process temperature, ohms or mV value depending on how the device is configured</p>
	<p>SV Screen: terminal temperature value</p>
	<p>TV Screen: feature board temperature value</p>
	<p>QV Screen: voltage reading at the power module terminals</p>

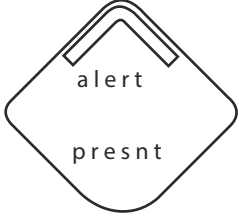
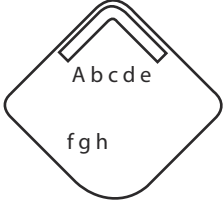
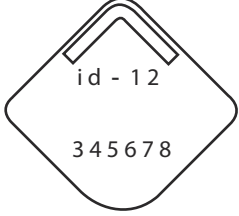
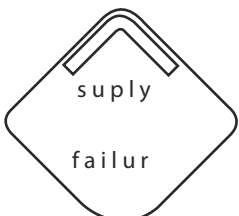
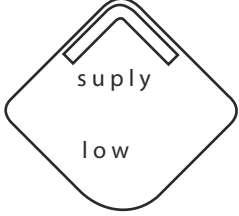
	<p>Alert Screen: at least one alert is present - this screen will not display if no alerts are present</p>
	<p>Diagnostic Button Screen 1 - Tag: user entered tag which is 8 characters long - will not display if all characters are blank</p>
	<p>Diagnostic Button Screen 2: the device's identifier that is used to make up the HART long address - the Smart Wireless Gateway may use this to help identify devices if no unique user tag is available</p>
	<p>Diagnostic Button Screen 7.1: the terminal voltage has dropped below level of operating limit. Replace the Power Module (Part Number: 00753-9220-0001)</p>
	<p>Diagnostic Button Screen 7.2: the terminal voltage is below the recommended operating range - if this is a self-powered device, the power module should be replaced - for line powered devices, the supply voltage should be increased</p>

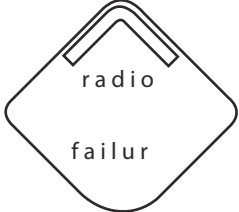
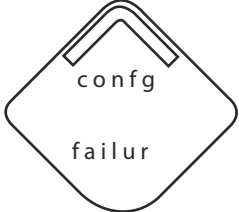
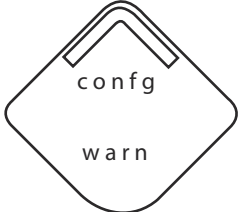
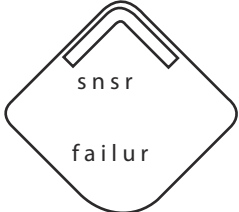
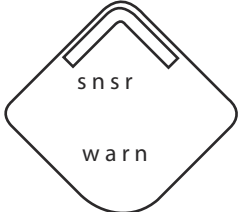
	<p>Diagnostic Button Screen 8: the device cannot retrieve information from the radio in the device - the device may still be operational and publishing HART data</p>
	<p>Diagnostic Button Screen 9.1: configuration of the transmitter is invalid such that critical operation of the device may be affected - check the extended configuration status to identify which configuration item(s) need to be corrected</p>
	<p>Diagnostic Button Screen 9.2: configuration of the transmitter is invalid such that non-critical operation of the device may be affected - check the extended configuration status to identify which configuration item(s) need to be corrected</p>
	<p>Diagnostic Button Screen 10.1: a sensor attached to the transmitter has failed, and valid readings from that sensor are no longer possible - check the sensor and sensor wiring connections - check additional status for more detailed information of the failure source</p>
	<p>Diagnostic Button Screen 10.2: a sensor attached to the transmitter is degraded, readings from that sensor may not be within accuracy specifications - check the process, and sensor wiring connections - check additional status for more detailed information of the warning source</p>

Note

Use the Rosemount Wireless LCD display part number: 00753-9004-0002.

5.2 Power module replacement

Expected black power module life is 10 years at reference conditions. ⁽¹⁾

When module replacement is required perform the following procedure.

5.2.1 Replace the power module

Procedure

1. Remove the cover and module.
2. Replace the module (part number 701PBKKF) and cover.
3. Tighten to specification and verify operation.

5.2.2 Handling considerations

The Black Power Module with the wireless unit contains two “C” size primary lithium-thionyl chloride battery (Black Power Module, model number 701PBKKF). Each battery contains approximately 5.0 grams of lithium. Under normal conditions, the battery materials are self-contained and are not reactive as long as the batteries and the pack integrity are maintained. Care should be taken to prevent thermal, electrical, or mechanical damage.

Contacts should be protected to prevent premature discharge.

Black Power Module should be stored in a clean and dry area. For maximum Black Power Module life, storage temperature should not exceed 86 °F (30 °C).

Note

Continuous exposure to ambient temperature limits of –40 °F or 185 °F (–40 °C or 85 °C) may reduce specified life by less than 20 percent.

Use caution when handling the Black Power Module, it may be damaged if dropped from heights in excess of 20 ft.

Battery hazards remain when cells are discharged.

5.2.3 Environmental considerations

As with any battery, local environmental rules and regulations should be consulted for proper management of spent batteries. If no specific requirements exist, recycling through a qualified recycler is encouraged. Consult the materials safety data sheet for battery specific information.

5.2.4 Shipping considerations

The unit was shipped to you without the Black Power Module installed. Remove the module prior to shipping the unit.

(1) Reference conditions are 70 °F (21° C), transmit rate of once per minute, and routing data for three additional network devices.

6 Troubleshooting

6.1 Overview

The following tables provide summarized maintenance and troubleshooting suggestions for the most common operating problems. If you suspect malfunction despite the absence of any diagnostic messages on the Field Communicator display, follow the procedures described here to verify transmitter hardware and process connections are in good working order. Always deal with the most likely checkpoints first.

6.1.1 Device status

Electronics failure

Description

An electronics error that could impact the device measurement reading has occurred.

Recommended actions

1. Reset the device.
2. Reconfirm all configuration items in the device.
3. If the condition persists, replace the electronics.

Terminal block failure

Description

A critical failure has occurred in the transmitter's terminal block.

Recommended actions

1. Reset the device.
2. Replace the terminal block.

Sensor failure

Description

The device has detected an open, short, or too much resistance for this sensor.

Recommended actions

1. Verify the sensor connection and wiring. Refer to the wiring diagrams found on the terminal compartment to ensure proper wiring.
2. Verify the integrity of the sensor and sensor lead wires. If the sensor is faulty, repair or replace the sensor.
3. Reconfirm sensor configuration.
4. Replace the sensor.

5. If problem persists, replace the electronics.

Radio failure

Description

The wireless radio has detected a failure or stopped communicating.

Recommended actions

1. Reset the device.
2. If the condition persists, replace the electronics.

Supply voltage failure

Description

The supply voltage is too low for the device to broadcast updates.

Recommended actions

Replace the power module.

Electronics warning

Description

The device has detected an electronics error that does not currently impact the device measurement reading.

Recommended actions

1. Reset the device.
2. Reconfirm all configuration items in the device.
3. If the condition persists, replace the electronics.

Sensor has exceeded limits

Description

The sensor has exceeded the maximum measurement range.

Recommended actions

1. Check process for possible saturation condition.
2. Verify the appropriate sensor was chosen for the application.
3. Reconfirm sensor configuration.
4. Reset the device.
5. Replace the sensor.

Electronics temperatures has exceeded limits

Description

The electronics temperature has exceeded the transmitter's maximum range.

Recommended actions

1. Verify environmental temperature is within the transmitter's range.
2. Remote mount the transmitter away from process and environmental conditions.
3. Reset the device.
4. If the condition persists, replace the electronics.

Terminal temperature has exceeded limits

Description

The terminal temperature has exceed the transmitter's maximum range.

Recommended actions

1. Verify environmental temperature is within the transmitter's range.
2. Remote mount the transmitter away from process and environmental conditions.
3. Reset the device.
4. If the condition persists, replace the electronics.

Supply voltage low

Description

The supply voltage is low and may soon affect broadcast updates.

Recommended actions

Replace the power module.

Database memory warning

Description

The device has failed to write to the database memory. Any data written during this time may have been lost.

Recommended actions

1. Reset the device.
2. Reconfirm all configuration items in the device.
3. If logging dynamic data not needed, this advisory can be safely ignored.
4. If the condition persists, replace the electronics.

Invalid Configuration

Description

The device has detected a configuration error based on a change to the device.

Recommended actions

1. Select details for more information.
2. Correct the parameter that has a configuration error.
3. Reset the device.
4. If the condition persists, replace the electronics.

Hi Hi alarm

Description

The primary variable has surpassed the user defined limit.

Recommended actions

1. Verify the process variable is within user specified limits.
2. Reconfirm the user defined alarm limit.
3. If not needed, disable this alert.

Hi alarm

Description

The primary variable has surpassed the user defined limit.

Recommended actions

1. Verify the process variable is within user specified limits.
2. Reconfirm the user defined alarm limit.
3. If not needed, disable this alert.

Lo alarm

Description

The primary variable has surpassed the user defined limit.

Recommended actions

1. Verify the process variable is within user specified limits.
2. Reconfirm the user defined alarm limit.
3. If not needed, disable this alert.

Lo Lo alarm

Description

The primary variable has surpassed the user defined limit

Recommended actions

1. Verify the process variable is within user specified limits.
2. Reconfirm the user defined alarm limit.

3. If not needed, disable this alert.

Button stuck

Description

A button on the Electronic Board is detected as stuck in the active position.

Recommended actions

1. Check the buttons for obstructions.
2. Reset the device.
3. If conditions persist, replace the electronics.

Simulation active

Description

The device is in simulation mode and may not be reporting actual information.

Recommended actions

1. Verify simulation is no longer required.
2. Disable Simulation mode in Service Tools.
3. Reset the device.

6.1.2 Transmitter output

High output temperature detected

Potential cause

Sensor input failure or connection

Recommended actions

1. Connect a Field Communicator and enter the transmitter test mode to isolate a sensor failure.
2. Check for a sensor open or short circuit.
3. Check the process variable to see if it is out of range.

Potential cause

Electronics module

Recommended actions

1. Connect a Field Communicator and enter the transmitter status mode to isolate module failure.
2. Connect a Field Communicator and check the sensor limits to ensure calibration adjustments are within the sensor range.

Digital temperature output is erratic

Potential cause

Wiring

Recommended actions

Check sensor wiring integrity at all junctions to ensure proper connections.

Potential cause

Electronics module

Recommended actions

Connect a Field Communicator and enter the transmitter test mode to isolate module failure.

Low output or no output

Potential cause

Sensor element

Recommended actions

1. Connect a Field Communicator and enter the transmitter test mode to isolate a sensor failure.
2. Check the process variable to see if it is out of range.

6.1.3 LCD display

LCD display not operating

Potential cause

Electronic module

Recommended actions

Ensure the LCD display is enabled.

Potential cause

Connector

Recommended actions

Ensure the LCD display pins are not bent.

Potential cause

LCD display

Recommended actions

Ensure the LCD display is properly seated with the tabs snapped in place and fully engaged.

6.1.4 Wireless network

Device not joining the network

Recommended actions

1. Verify network ID and join key.
2. Verify network is in active network advertise.
3. Wait longer (30 minutes).
4. Check power module.
5. Verify device is within range of at least one other device.
6. Power cycle device to try again.
7. Verify device is configured to join. Ensure the Join Mode is configured to “Join on Powerup or Reset”.

Short battery life

Recommended actions

1. Check that “Power Always On” mode is off.
2. Verify device is not installed in extreme temperatures.
3. Verify device is not a network pinch point.
4. Check for excessive network rejoins due to poor connectivity.

Limited bandwidth error

Recommended actions

1. Reduce the update rate on transmitter.
2. Increase communication paths by adding more wireless points.
3. Check that device has been on line for at least an hour.
4. Check that device is not routing through a “limited” routing node.
5. Create a new network with an additional Wireless Gateway.

A Reference data

A.1 Ordering information, specifications, and drawings

To view current Rosemount 648 Wireless Temperature Transmitter ordering information, specifications, and drawings, follow these steps:

Procedure

1. Go to [Emerson.com/Rosemount/Rosemount-648](https://emerson.com/Rosemount/Rosemount-648).
2. Scroll as needed to the green menu bar and click **Documents & Drawings**.
3. For installation drawings, click **Drawings & Schematics**.
4. Select the appropriate Product Data Sheet.
5. For ordering information, specifications, and dimensional drawings, click **Data Sheets & Bulletins**.
6. Select the appropriate Product Data Sheet.

A.2 Product certifications

To view current Rosemount 648 Wireless Temperature Transmitter product certifications, follow these steps:

Procedure

1. Go to [Emerson.com/Rosemount/Rosemount-648](https://emerson.com/Rosemount/Rosemount-648).
2. Scroll as needed to the green menu bar and click **Documents & Drawings**.
3. Click **Manuals & Guides**.
4. Select the appropriate Quick Start Guide.

B Mapping for Non-DD Based Integration with Host Systems

B.1 Alert message mapping

This outlines the most important alerts in the HART command 48 Additional Status Field for the Rosemount 648 Wireless Temperature Transmitter. The information in this section can be used by DeltaV™ for alert monitoring, and in the Rosemount 1420 Wireless Gateway for Additional Status mapping in Modbus®, OPC UA®, etc.

A complete list of additional status bits is available in the Rosemount 1420 [Reference Manual](#).

[Table B-1](#) to [Table B-2](#) shows a list of the most important alert messages that may display in the AMS Wireless Configurator and Field Communicator together with the location of the Alert in the HART command 48 Additional Status field. For recommended actions refer to [Troubleshooting](#).

To view Active Alerts, from the *Home* screen, go to **Service Tools** → **Active Alerts**.

Table B-1: Failure Alerts (F:)

Message	Additional status ⁽¹⁾	Description
Electronics Failure	Byte 0 :: Bit 0 Byte 0 :: Bit 1 Byte 0 :: Bit 3 Byte 0 :: Bit 6 Byte 0 :: Bit 7 Byte 8 :: Bit 1 Byte 8 :: Bit 2 Byte 8 :: Bit 6	An electronics error that could impact the device measurement reading has occurred
Terminal Block Failure	Byte 3 :: Bit 2 Byte 3 :: Bit 3 Byte 3 :: Bit 6	A critical failure has occurred in the transmitter's terminal block
Sensor Failure	Byte 3 :: Bit 7	The device has detected an open, short, or too much resistance for this sensor
Radio Failure	Byte 1 :: Bit 1 Byte 1 :: Bit 7	The wireless radio has detected a failure or stopped communicating
Supply Voltage Failure	Byte 1 :: Bit 4 Byte 5 :: Bit 2	The supply voltage is too low for the device to broadcast
Electronics Warning	Byte 0 :: Bit 4 Byte 0 :: Bit 5	The device has detected an electronics error that does not currently impact the device measurement reading

Table B-1: Failure Alerts (F:) (continued)

Message	Additional status ⁽¹⁾	Description
Sensor has Exceeded Limits	Byte 3 :: Bit 4 Byte 3 :: Bit 5	The sensor has exceeded the maximum measurement range
Electronics Temperature has Exceeded Limits	Byte 1 :: Bit 2 Byte 1 :: Bit 3 Byte 8 :: Bit 5	The terminal temperature has exceeded the transmitter's maximum range
Electronics Temperature has Exceeded Limits	Byte 3 :: Bit 0 Byte 3 :: Bit 1	The electronics temperature has exceeded the transmitter's maximum range.
Supply Voltage Low	Byte 1 :: Bit 6 Byte 8 :: Bit 4	The supply voltage is low and may soon affect broadcast updates

(1) Location of the Alert in the HART command 48 Status field.

Table B-2: Advisory Alerts (A:)

Message	Additional status ⁽¹⁾	Description
Database Memory Warning	Byte 0 :: Bit 2	The device has failed to write to the database memory / Any data written during this time may have been lost
Invalid Configuration	Byte 2 :: Bit 6	The device has detected a configuration error based on a change to the device
HI HI Alarm	Byte 5 :: Bit 4	The primary variable has surpassed the user defined limit
HI Alarm	Byte 5 :: Bit 5	The primary variable has surpassed the user defined limit
LO Alarm	Byte 5 :: Bit 6	The primary variable has surpassed the user defined limit
LO LO Alarm	Byte 5 :: Bit 7	The primary variable has surpassed the user defined limit
Button Stuck	Byte 1 :: Bit 5	A button on the Electronics Board is detected as stuck in the active position
Simulation Active	Byte 8 :: Bit 0	The device is in simulation mode and may not be reporting actual information

(1) Location of the Alert in the HART command 48 Status field.

B.2 Mapping of device variable index numbers

To integrate a device into the host system, it may be necessary to know what each device variable represents, and what index number it has been assigned to. The variable index number is an arbitrary number used to uniquely identify each variable supported in the field device.

Table B-3 to Table B-4 displays the device variable and variable mapping indexes for the Rosemount 648 Wireless.

Table B-3: Device Variable Index

Device variable index	Description
0	Supply Voltage
1	Electronics Temperature
2	Process Temperature
3	Terminal Temperature (for CJC)
244	Percent of Range

Table B-4: Variable Mapping

Process variable	Mapped variable index
PV	2 - Process Temperature
SV	3 - Terminal Temperature
TV	1 - Electronics Temperature
QV	0 - Supply Voltage

Global Headquarters

Emerson Automation Solutions
6021 Innovation Blvd.
Shakopee, MN 55379, USA

+1 800 999 9307 or +1 952 906 8888

+1 952 204 8889

RFQ.RMD-RCC@Emerson.com

North America Regional Office

Emerson Automation Solutions
8200 Market Blvd.
Chanhassen, MN 55317, USA

+1 800 999 9307 or +1 952 906 8888

+1 952 204 8889

RMT-NA.RCCRFQ@Emerson.com

Latin America Regional Office

Emerson Automation Solutions
1300 Concord Terrace, Suite 400
Sunrise, FL 33323, USA

+1 954 846 5030

+1 954 846 5121

RFQ.RMD-RCC@Emerson.com

Europe Regional Office

Emerson Automation Solutions Europe
GmbH
Neuhofstrasse 19a P.O. Box 1046
CH 6340 Baar
Switzerland

+41 (0) 41 768 6111

+41 (0) 41 768 6300

RFQ.RMD-RCC@Emerson.com

Asia Pacific Regional Office

Emerson Automation Solutions
1 Pandan Crescent
Singapore 128461

+65 6777 8211

+65 6777 0947

Enquiries@AP.Emerson.com

Middle East and Africa Regional Office

Emerson Automation Solutions
Emerson FZE P.O. Box 17033
Jebel Ali Free Zone - South 2
Dubai, United Arab Emirates

+971 4 8118100

+971 4 8865465

RFQ.RMTMEA@Emerson.com

 [Linkedin.com/company/Emerson-Automation-Solutions](https://www.linkedin.com/company/Emerson-Automation-Solutions)

 [Twitter.com/Rosemount_News](https://twitter.com/Rosemount_News)

 [Facebook.com/Rosemount](https://www.facebook.com/Rosemount)

 [Youtube.com/user/RosemountMeasurement](https://www.youtube.com/user/RosemountMeasurement)

©2020 Emerson. All rights reserved.

Emerson Terms and Conditions of Sale are available upon request. The Emerson logo is a trademark and service mark of Emerson Electric Co. Rosemount is a mark of one of the Emerson family of companies. All other marks are the property of their respective owners.

