

Operating Instructions

iTEMP TMT112

Dual-Input Temperature Transmitter

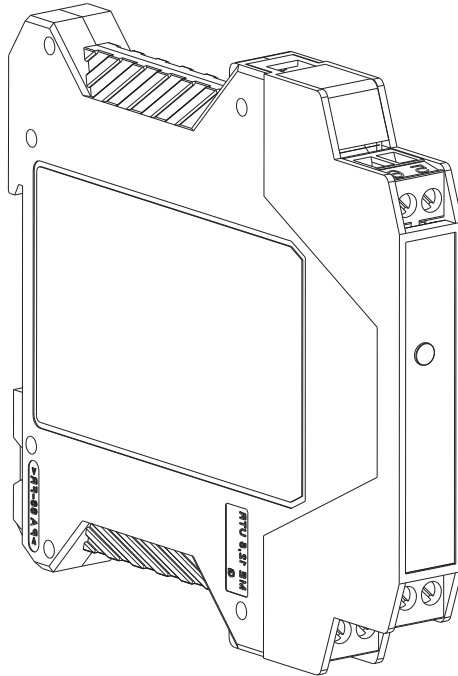

Table of contents

1	About this document	4	8	Diagnostics and troubleshooting	22
1.1	Document function	4	8.1	General troubleshooting	22
1.2	Safety Instructions (XA)	4	8.2	Application fault messages	23
1.3	Symbols used	4	8.3	Application faults without messages ...	23
1.4	Tool symbols	6	8.4	Firmware history	25
1.5	Documentation	6	9	Repair	25
1.6	Registered trademarks	7	9.1	Spare parts	25
2	Basic safety instructions	7	9.2	Return	25
2.1	Requirements for the personnel	7	9.3	Disposal	26
2.2	Designated use	7	10	Maintenance	26
2.3	Operational safety	7	11	Accessories	26
3	Incoming acceptance and product identification	8	12	Technical data	26
3.1	Incoming acceptance	8	12.1	Input	26
3.2	Product identification	9	12.2	Output	28
3.3	Scope of delivery	10	12.3	Power supply	28
3.4	Certificates and approvals	10	12.4	Performance characteristics	29
3.5	Transport and storage	11	12.5	Installations condistions	31
4	Mounting	11	12.6	Environment	31
4.1	Mounting requirements	11	12.7	Mechanical construction	32
4.2	Mounting the DIN rail transmitter	12	12.8	Human interface	32
4.3	Post-installation check	12	12.9	Certificates and approvals	33
5	Electrical connection	12			
5.1	Quick wiring guide	13			
5.2	Connecting the sensor cables	13			
5.3	Connecting the output signal and power supply	13			
5.4	HART [®] connecting	13			
5.5	Shielding and grounding	15			
5.6	Post-connection check	15			
6	Operation options	15			
6.1	Overview of operation options	15			
6.2	Access to the operating menu via the operating tool	15			
7	Commissioning	16			
7.1	Installation and function check	16			
7.2	Commissioning	16			

1 About this document

1.1 Document function





These Operating Instructions contain all the information that is required in various phases of the life cycle of the device: from product identification, incoming acceptance and storage, to mounting, connection, operation and commissioning through to troubleshooting, maintenance and disposal.

1.2 Safety Instructions (XA)



When using in hazardous areas, compliance with national regulations is mandatory. Separate Ex-specific documentation is provided for measuring systems that are used in hazardous areas. This documentation is an integral part of these Operating Instructions. The installation specifications, connection data and safety instructions it contains must be strictly observed! Make sure that you use the right Ex-specific documentation for the right device with approval for use in hazardous areas! The number of the specific Ex documentation (XA...) is provided on the nameplate. If the two numbers (on the Ex documentation and the nameplate) are identical, then you may use this Ex-specific documentation.



1.3 Symbols used

1.3.1 Safety symbols













Symbol	Meaning
	DANGER! This symbol alerts you to a dangerous situation. Failure to avoid this situation will result in serious or fatal injury.
	WARNING! This symbol alerts you to a dangerous situation. Failure to avoid this situation can result in serious or fatal injury.
	CAUTION! This symbol alerts you to a dangerous situation. Failure to avoid this situation can result in minor or medium injury.
	NOTE! This symbol contains information on procedures and other facts which do not result in personal injury.

1.3.2 Electrical symbols



Symbol	Meaning
	Direct current
	Alternating current
	Direct current and alternating current

Symbol	Meaning
	<p>Ground connection</p> <p>A grounded terminal which, as far as the operator is concerned, is grounded via a grounding system.</p>
	<p>Protective Earth (PE)</p> <p>A terminal which must be connected to ground prior to establishing any other connections.</p> <p>The ground terminals are situated inside and outside the device:</p> <ul style="list-style-type: none"> ▪ Inner ground terminal: Connects the protective earth to the mains supply. ▪ Outer ground terminal: Connects the device to the plant grounding system.





1.3.3 Symbols for certain types of information

Symbol	Meaning
	<p>Permitted</p> <p>Procedures, processes or actions that are permitted.</p>
	<p>Preferred</p> <p>Procedures, processes or actions that are preferred.</p>
	<p>Forbidden</p> <p>Procedures, processes or actions that are forbidden.</p>
	<p>Tip</p> <p>Indicates additional information.</p>
	Reference to documentation.
	Reference to page.
	Reference to graphic.
	Notice or individual step to be observed.
	Series of steps.
	Result of a step.
	Help in the event of a problem.
	Visual inspection.

1.3.4 Symbols in graphics

Symbol	Meaning	Symbol	Meaning
1, 2, 3,...	Item numbers		Series of steps
A, B, C, ...	Views	A-A, B-B, C-C, ...	Sections
	Hazardous area		Safe area (non-hazardous area)

1.4 Tool symbols

Symbol	Meaning
 A0011220	Flat blade screwdriver
 A0011219	Phillips head screwdriver
 A0011221	Allen key
 A0011222	Open-ended wrench
 A0013442	Torx screwdriver

1.5 Documentation

Document	Purpose and content of the document
Technical Information TI00114R/09/EN	Planning aid for your device The document contains all the technical data on the device and provides an overview of the accessories and other products that can be ordered for the device.
Brief Operating Instructions KA193R/09/EN	Guide that takes you quickly to the 1st measured value The Brief Operating Instructions contain all the essential information from incoming acceptance to initial commissioning.

 The document types listed are available:
In the Download Area of the Endress+Hauser Internet site: www.endress.com → Download

1.6 Registered trademarks

- HART®
Registered trademark of the HART® FieldComm Group
- Microsoft®, Windows NT® and Windows® 2000
Registered trademarks of Microsoft Corporation, Redmond, USA

2 Basic safety instructions

2.1 Requirements for the personnel

The personnel for installation, commissioning, diagnostics and maintenance must fulfill the following requirements:

- ▶ Trained, qualified specialists must have a relevant qualification for this specific function and task
- ▶ Are authorized by the plant owner/operator
- ▶ Are familiar with federal/national regulations
- ▶ Before beginning work, the specialist staff must have read and understood the instructions in the Operating Instructions and supplementary documentation as well as in the certificates (depending on the application)
- ▶ Following instructions and basic conditions

The operating personnel must fulfill the following requirements:

- ▶ Being instructed and authorized according to the requirements of the task by the facility's owner-operator
- ▶ Following the instructions in these Operating Instructions

2.2 Designated use

The unit is a presettable temperature transmitter for resistance thermometer (RTD), thermocouple (TC) as well as resistance and voltage sensors. The unit is constructed for mounting on a DIN rail.

The manufacturer is not liable for damage caused by improper or non-designated use.

Separate Ex documentation is part of this operating manual, for measurement systems in hazardous areas. The installation conditions and connection values indicated in these instructions must be followed.

2.3 Operational safety

- ▶ Operate the device in proper technical condition and fail-safe condition only.
- ▶ The operator is responsible for interference-free operation of the device.

Hazardous area

To eliminate a danger for persons or for the facility when the device is used in the hazardous area (e.g. explosion protection or safety equipment):

- ▶ Based on the technical data on the nameplate, check whether the ordered device is permitted for the intended use in the hazardous area. The nameplate can be found on the side of the transmitter housing.
- ▶ Observe the specifications in the separate supplementary documentation that is an integral part of these Instructions.

Electromagnetic compatibility

The measuring system complies with the general safety requirements as per EN 61010-1, the EMC requirements as per the IEC/EN 61326 series and the NAMUR recommendations NE 21 and NE 43.

-  The device must only be powered by a power unit that operates using an energy-limited electric circuit according to UL/EN/IEC 61010-1, chapter 9.4 and requirements of table 18.

Technical advancement

The manufacturer reserves the right to modify technical data without prior notice. Your distributor can supply you with current information and updates to these Operating Instructions.

3 Incoming acceptance and product identification

3.1 Incoming acceptance

1. Unpack the temperature transmitter carefully. Is the packaging or content damaged?
 - ↳ Damaged components may not be installed as the manufacturer can otherwise not guarantee compliance with the original safety requirements or the material resistance, and can therefore not be held responsible for any resulting damage.
2. Is the delivery complete or is anything missing? Check the scope of delivery against your order.

3.

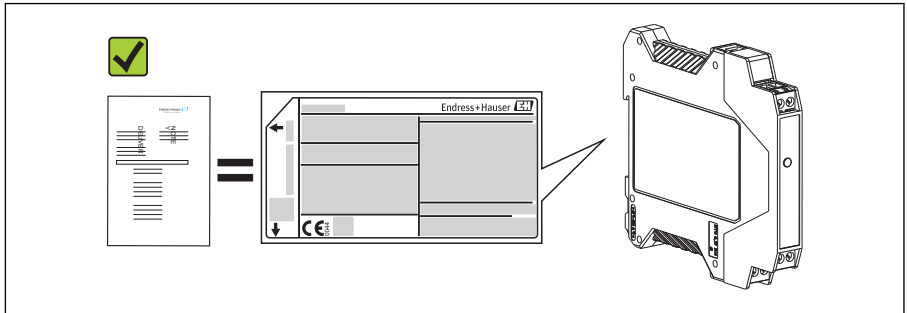

A0040282

Does the nameplate match the ordering information on the delivery note?

4.

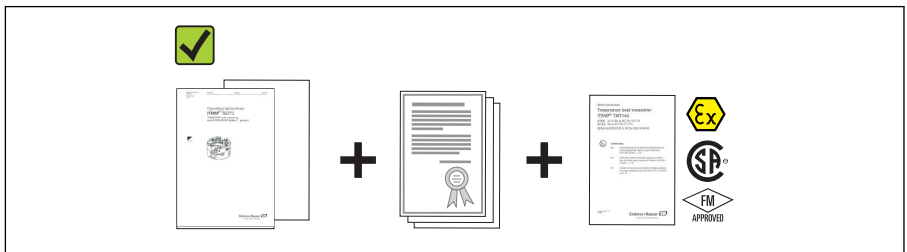

A0024858

Are the technical documentation and all other necessary documents provided? If applicable: are the Safety Instructions (e.g. XA) for hazardous areas provided?



If one of these conditions is not satisfied, contact your Endress+Hauser Sales Center.

3.2 Product identification

The following options are available for identification of the device:

- Nameplate specifications
- Enter the serial number from the nameplate in the *W@M Device Viewer* (www.endress.com/deviceviewer): All data relating to the device and an overview of the Technical Documentation supplied with the device are displayed.
- Enter the serial number on the nameplate into the *Endress+Hauser Operations App* or scan the 2-D matrix code (QR code) on the nameplate with the *Endress+Hauser Operations App*: all the information about the device and the technical documentation pertaining to the device is displayed.

3.2.1 Nameplate

The right device?

Compare and check the data on the nameplate of the device against the requirements of the measuring point:

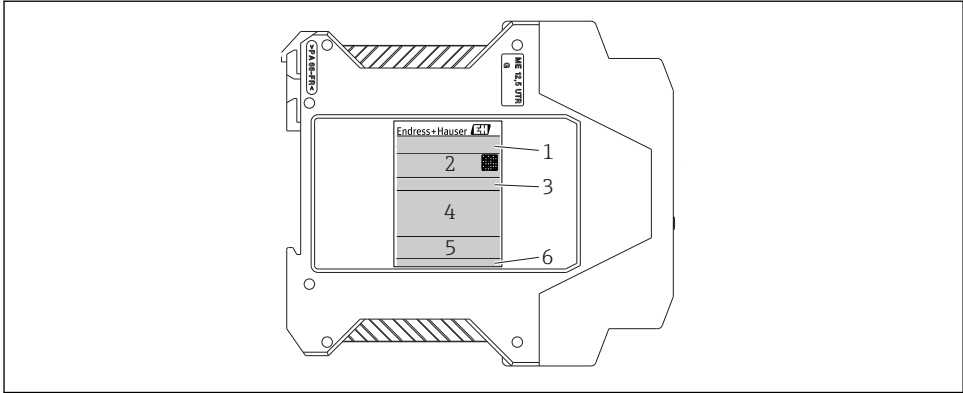

A0040384

1 Nameplate of DIN rail transmitter (example, Ex version)

- 1 Product name
- 2 Order code, extended order code and serial number, firmware version, data matrix 2D code, 2 lines for the TAG name
- 3 Configuration
- 4 Power supply and current consumption, output, approval in hazardous area with connection data
- 5 Approval logos
- 6 Manufacturer ID

3.2.2 Name and address of manufacturer

Name of manufacturer:	Endress+Hauser Wetzter GmbH + Co. KG
Address of manufacturer:	Obere Wank 1, D-87484 Nesselwang oder www.endress.com
Address of manufacturing plant:	See nameplate

3.3 Scope of delivery

The scope of delivery of the device comprises:

- Temperature transmitter
- Additional documentation for devices which are suitable for use in the hazardous area (Ex), such as:
 - XA00018R/09/a3
 - XA00022R/09/a3
 - ZD031R/09/EN
 - ZD037R/09/EN

3.4 Certificates and approvals

The device left the factory in a safe operating condition. The device complies with the requirements of the standards EN 61 010-1 "Safety Requirements for Electrical Equipment for Measurement, Control, and Laboratory Use" and with the EMC requirements as per the IEC/EN 61326 series.

3.4.1 CE/EAC mark, declaration of conformity

The device meets the legal requirements of the EU/EEU guidelines. The manufacturer confirms that the device is compliant with the relevant guidelines by applying the CE/EAC mark.

3.4.2 HART® protocol certification

The temperature transmitter is registered by the HART® FieldComm Group. The device meets the requirements of the HART® Communication Protocol Specifications, Revision 5.

3.5 Transport and storage

Carefully remove all the packaging material and protective covers that are part of the transported package.



Dimensions and operating conditions: → 32

When storing (and transporting) the device, pack it so that it is reliably protected against impact. The original packaging offers the best protection.

Storage temperature

DIN rail device: -50 to +100 °C (-58 to +212 °F)

4 Mounting

4.1 Mounting requirements

When mounting and operating the device, please take note of the allowable ambient temperature → 26.

When using the device in a hazardous area, the limits indicated in the certification must be adhered to (see control drawing).

4.1.1 Dimensions

The dimensions of the device are provided in the "Technical data" section → 26.

4.1.2 Mounting location

Mounting on DIN rail according to IEC 60715, e.g. in control panel.

4.1.3 Mounting angle

There are no limits as to the angle of mounting.

4.2 Mounting the DIN rail transmitter

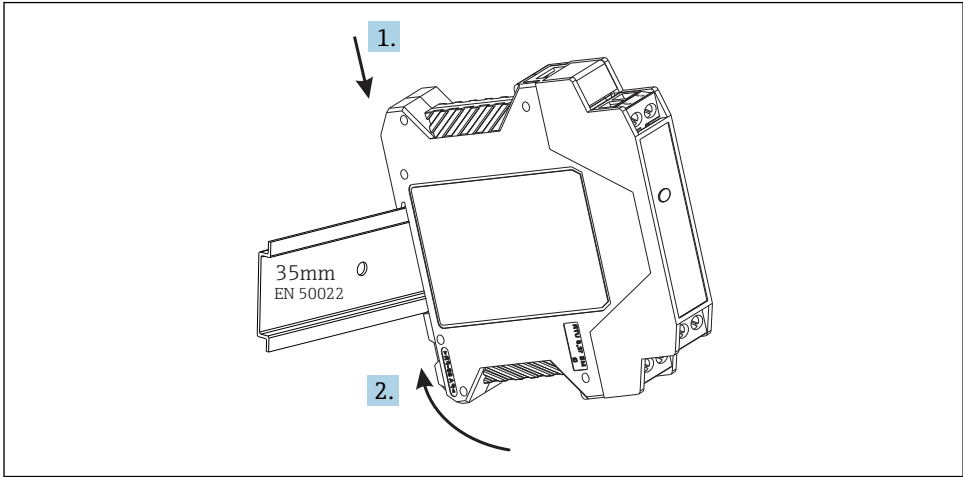

A0040216

4.3 Post-installation check

After installing the device, always run the following final checks:

Device condition and specifications	Notes
Is the device undamaged (visual inspection)?	-
Do the ambient conditions match the device specification (e.g. ambient temperature, measuring range, etc.)?	See 'Technical data' section → 26

5 Electrical connection

⚠ CAUTION

- Switch off the power supply before installing or connecting the device. Failure to observe this may result in the destruction of parts of the electronics.

5.1 Quick wiring guide

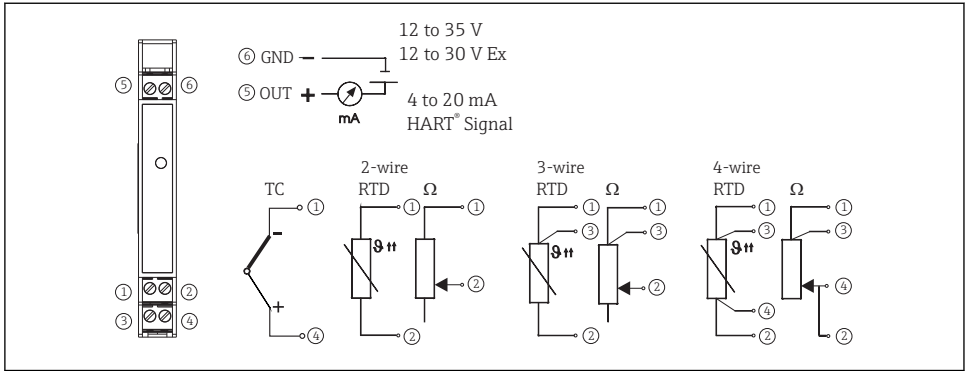

2 DIN rail transmitter wiring

5.2 Connecting the sensor cables

Connect the sensor cables to the respective DIN rail transmitter terminals (Terminals 1 to 4) by following the wiring diagram → 2, 13. Wiring plugs are removable for easy access.

5.3 Connecting the output signal and power supply

Connect the cable wires from the power supply to terminal 5 and 6 according to the wiring diagram → 2, 13. For convenient installation, the connection is designed as a removable plug, so the connection can be made on the terminals, then plug in the connection socket to the transmitter housing.

i The screws on the terminals must be screwed in tightly.

5.4 HART® connecting

Connection is made directly using the 4 to 20 mA signal cables or the communication sockets fitted to a power supply or barrier. In order to connect the transmitter in a hazardous area, please read the separate Ex documentation.

i The measurement circuit must have a load of at least 250 Ω (see → 3, 14 and → 4, 14).

Connection of a HART® communicator Model 375

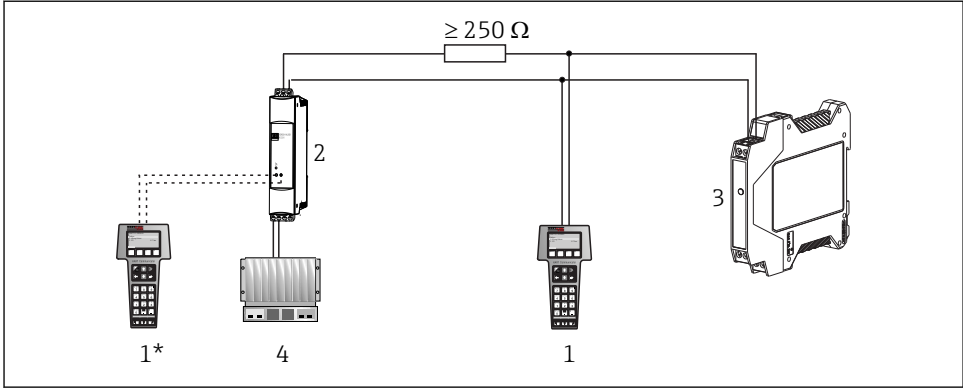

A0040218

3 Electrical connection of the HART® communicator Model 375

- 1 HART® module
- 1* HART® module connected to the communication sockets of a power supply
- 2 Loop power supply
- 3 DIN rail temperature transmitter
- 4 PLC with passive input

Connection of the HART® -modem

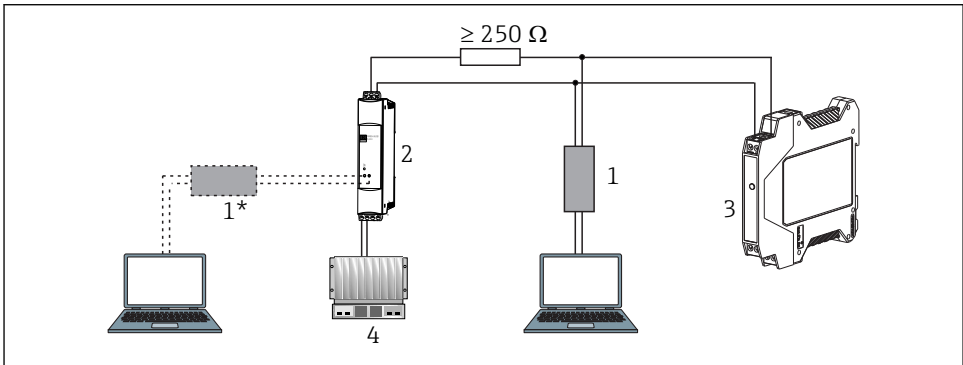

A0040219

4 Electrical connection of the HART® -modem

- 1 HART® -modem (in combination with a PC operating software)
- 1* HART® -modem connected to the communication sockets of a power supply unit
- 2 Loop power supply
- 3 DIN rail temperature transmitter
- 4 PLC with passive input

5.5 Shielding and grounding

The specifications of the HART® FieldComm Group must be observed when installing a HART® transmitter.

5.6 Post-connection check

Device condition and specifications	Notes
Is the device or cable undamaged (visual check)?	--
Electrical connection	Notes
Does the supply voltage match the specifications on the nameplate?	DIN rail transmitter: <ul style="list-style-type: none"> ■ 12 to 35 V_{DC} ■ 12 to 30 V (Ex)
Do the cables have adequate strain relief?	--
Are the power supply and signal cables correctly connected?	→  13
Are all the screw terminals well tightened and checked?	--

6 Operation options

6.1 Overview of operation options

The DIN rail temperature transmitter is set up using the HART® protocol. The values measured can also be read using the HART® protocol. In order to do this the user has two possibilities:

- Operation using a universal hand operated module “HART® Field Communicator 375/475”.
- Operation using a PC and operating software as well as a HART® modem.

6.2 Access to the operating menu via the operating tool

6.2.1 Field Communicator 375/475

Selection of the unit functions using the “HART® Communicator” is done using various menu levels as well as with the help of a special HART® function matrix (see →  16).



- When using the HART® communicator all parameters can be read out, however, programming is locked. It is possible to access the HART® function matrix by entering 281 in the LOCK function. This condition remains even after a power failure. The HART® function matrix can be locked again by entering the personal code number.
- More detailed information on the ‘HART® Communicator’ can be found in the respective operating manual in the carrying case.

Source for device description files

The suitable device driver software (DD/DTM) for the individual operating tools can be acquired from a variety of sources:

- www.endress.com --> Downloads --> Search field: Software --> Software type: Device driver
- www.endress.com --> Products: individual product page, e.g. TMTxy --> Documents/Manuals/Software: Electronic Data Description (EDD) or Device Type Manager (DTM).
- Via DVD (please contact your local Endress+Hauser Sales Center)



Endress+Hauser supports all common operating tools from a variety of manufacturers (e.g. Emerson Process Management, ABB, Siemens, Yokogawa, Honeywell and many others). Endress+Hauser's FieldCare and DeviceCare operating tools are available for download (www.endress.com --> Downloads --> Search field: Software --> Application software) or on the optical data storage medium (DVD) which you can obtain from your local Endress +Hauser Sales Center.

7 Commissioning

7.1 Installation and function check

Installation check

Before commissioning the measuring point make sure that all final checks have been carried out:

- "Post-installation check" checklist →  12
- "Post-connection check" checklist →  15

Function check

Measuring the analog 4 to 20 mA output signal or following failure signals:

Measurement range undercut	linear fall to 3.8 mA
Measurement range excess	linear rise to 20.5 mA Measurement range undercut
Sensor break; sensor short circuit ¹⁾	≤ 3.6 mA or ≥21 mA

1) not for thermocouples

7.2 Commissioning

Once the power supply has been connected, the DIN rail temperature transmitter is operational.

7.2.1 Quick setup

Using the Quick Setup, the operator is led through all the most important unit functions that must be set up for standard measurement operation of the unit. Using the 'HART® Communicator' a quick setup of the black highlighted fields of the HART® function matrix is possible.

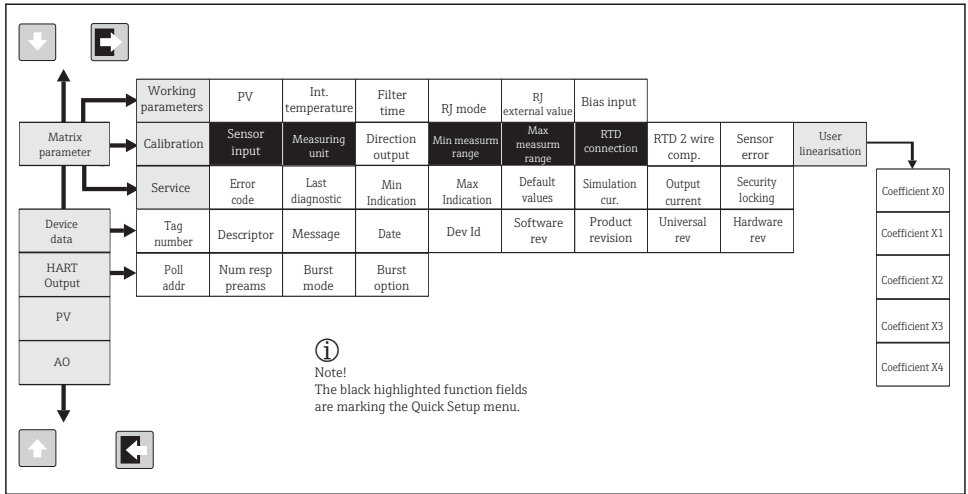

A0040284-EN

5 HART® function matrix

7.2.2 Configuration using HART® protocol and PC configuration software

The configuration of the transmitter can be done using both the HART® protocol and the PC configuration software. The following table shows the structure of the interactive menu led operation of the PC configuration software.

Configurable parameters (Unit function description see "Description of unit functions" on → 18)	
Standard settings	<ul style="list-style-type: none"> ▪ Sensortype ▪ Connection mode (2-, 3-, or 4-wire connection on RTD) ▪ Units (°C, °F or K) ▪ Measurement range start value ▪ Measurement range end value ▪ Coefficient X0 to X4 (on sensor type polynom RTD/TC) ▪ Temp.-compensation (on sensor type polynom TC)
Expanded settings	<ul style="list-style-type: none"> ▪ Cold junction compensation internal/external (on TC) ▪ external temperature (on TC with cold junction compensation external) ▪ Cable resistance compensation (on RTD 2-wire connection) ▪ Fault condition reaction ▪ Output (4 to 20 mA/20 to 4 mA) ▪ Damping (filter) ▪ Offset ▪ TAG (Measurement point description) ▪ Descriptor
Service functions	<ul style="list-style-type: none"> ▪ Output simulation (on/off) ▪ Reset to default ▪ Series number (only display) ▪ Operation code (=release code 281)

For detailed operating instructions for the PC configuration software, please read the documentation (Readme.txt) contained in the PC software (see folder "Doc").

Customer-specific linearization











Customer-specific linearization and sensor matching are activated after the **POLYNOM RTD** sensor type is selected. Pressing the “**LINEARIZATION**” key starts the **SMC 32** module. The sensor's support points and temperature deviation are entered in the **SMC 32**. Pressing the “**CALCULATE**” key calculates the linearization and “**OK**” adopts it into the PC configuration software. Linearization coefficients X0 to X4 are entered into the operating matrix or in the 'HART® Communicator'.

7.2.3 Description of unit functions















The following table contains a listing and description of all unit functions of the HART® protocol that can be used for setting up the DIN rail temperature transmitter.







 **Factory default values are shown in bold text.**

The 'HART® Communicator' display is indicated by the following symbol .

 PV (Primary value)	Display of actual measured temperature. Display: 7-digit number with floating decimal point and engineering unit. (e.g. 199.98 Ω; -62.36 °C, 407.76 °F)		
 Int. temperature	Display of the actual measured temperature of the internal comparison measurement point.  Display: 7-digit number with floating decimal point and engineering unit.		
Damping  Filter time	Digital filter selection 1 st grade. Input: 0 to 100 seconds 0 sec.		
Cold junction  RJ Mode	Selection of internal (Pt100) or external (0 to 80 °C (32 to 176 °F)) cold junction compensation. Entry: internal; external internal  Entry only possible on selection of thermocouple (TC) in unit function SENSOR TYPE. ¹⁾		
External temp. RJ external value	Entry of external cold junction value. Entry: -40 to 185 °F(-40 to 85 °C) (°C, °F, K) 0 °C  Entry only possible on selection of an external cold junction compensation in unit function RJ MODE.		
Offset  Bias input	Entry of zero point correction (Offset). Entry: -18.00 to 18.00 °F (10.00 to 10.00 °C) (°C, °F, K) 0.00 °C  Entry returns to factory default values when changing sensor type!		
Sensortype  Sensor input	Entry of sensor used:		
	Sensor type	Range start	Range end value

	10 to 75 mV	-10 mV	75 mV
	10 to 400 Ω	10 Ω	400 Ω
	10 to 2000 Ω	10 Ω	2000 Ω
	Pt100 DIN	-200 °C (-328 °F)	850 °C (1562 °F)
	Pt100 JIS	-200 °C (-328 °F)	649 °C (482 °F)
	Pt500	-200 °C (-328 °F)	250 °C (482 °F)
	Pt1000	-200 °C (-328 °F)	250 °C (482 °F)
	Ni100	-60 °C (-76 °F)	180 °C (356 °F)
	Ni500	-60 °C (-76 °F)	150 °C (302 °F)
	Ni1000	-60 °C (-76 °F)	150 °C (302 °F)
	Polynom RTD	-270 °C (-454 °F)	2500 °C (4532 °F)
	Type B	0 °C (32 °F)	1820 °C (3308 °F)
	Type C	0 °C (32 °F)	2320 °C (4208 °F)
	Type D	0 °C (32 °F)	2495 °C (4523 °F)
	Type E	-270 °C (-454 °F)	1000 °C (1832 °F)
	Type J	-210 °C (-346 °F)	1200 °C (2192 °F)
	Type K	-270 °C (-454 °F)	1372 °C (2501 °F)
	Type L	-200 °C (-328 °F)	900 °C (1652 °F)
	Type N	-270 °C (-454 °F)	1300 °C (2372 °F)
	Type R	-50 °C (-58 °F)	1768 °C (3214 °F)
	Type S	-50 °C (-58 °F)	1768 °C (3214 °F)
	Type T	-270 °C (-454 °F)	400 °C (752 °F)
	Type U	-200 °C (-328 °F)	600 °C (1112 °F)
	Polynom TC	-270 °C (-454 °F)	2500 °C (4532 °F)
	Pt100 DIN		
Temp. Compensation	Selection of temperature compensation of the cold junction when using customer specific linearization of the TC polynom Input: None, Type B, Type C, Type D, Type E, Type J, Type K, Type L, Type N, Type R, Type S, Type T, Type U None		
Unit Measuring unit	Enter engineering units. Entry: °C °F K °C		

Output current  Direction output	Enter standard (4 to 20 mA) or inverse (20 to 4 mA) current output signal. Entry: 4 to 20 mA 20 to 4 mA 4 to 20 mA
Range start value  Min. measurm. range	Entry: For limits see unit function SENSOR TYPE. 0 °C
Range end value  Max. measurm. range	Entry: For limits see unit function SENSOR TYPE. 100 °C
Connection  RTD RTD connection	Entry of RTD connection mode Entry: 2 wire 3 wire 4 wire 3 wire  Function field is only active on selection of resistance thermometer (RTD) in the unit function SENSOR TYPE.
Cable resistance  RTD 2 wire comp.	Entry of cable compensation on RTD 2 wire connection. Entry: 0.00 to 30.00 Ohm 0.00 Ω  Function field is only active on selection of 2 wire cable connection in unit function CONNECTION TYPE.
Fault condition  Sensor error	Entry of failure signal on sensor open or short circuit. Entry: max (≥ 21 mA) (≥ 3.6 mA) max
Coefficient X0 V3H0	Input of first coefficient for customer-specific linearization (polynome 4 th grade with five coefficients), see →  17.
Coefficient X1 V3H1	Input COEFFICIENT X1, see →  17.
Coefficient X2 V3H2	Input COEFFICIENT X2, see →  17.
Coefficient X3 V3H3	Input COEFFICIENT X3, see →  17.
Coefficient X4 V3H4	Input COEFFICIENT X4, see →  17.
Error code	Display of actual error code. Display: See “Application fault messages” on →  23. 0
Last diagnostic	Display of previous error code. Display: See “Application fault messages” on →  23. 0
Config. changed	Parameter changes are done. Display: Yes/No No

Min indication	<p>Display the minimum process value. The process value is accepted at the beginning of the measurement.</p> <p> Min. process value will be changed to the actual process value on access. On reset to factory default, the default value is entered.</p> <p>+10000</p>
Max indication	<p>Display the maximum process value. The process value is accepted at the beginning of the measurement.</p> <p> Max. process value will be changed to the actual process value on access. On reset to factory default, the default value is entered.</p> <p>-10000</p>
Default values	<p>Entry: 182 (Reset to factory default settings)</p> <p>0</p>
Output simulation  Simulation mode	<p>Entry of simulation mode.</p> <p>Entry: Off</p> <p>On</p> <p>Off</p>
Output current  Simulation value	<p>Entry of simulation value (current).</p> <p>Entry: 3.58 to 21.7 mA</p>
Keycode  Security locking	<p>Release code for setting up.</p> <p>Entry: Lock = 0</p> <p>Release = 281</p> <p>281</p>
Tag  Tag number	<p>Entry and display of measurement point description (TAG).</p> <p>Entry: 8 characters</p> <p>-</p>
Descriptor	<p>Entry and display of plant description.</p> <p>Entry: 16 characters</p> <p>-</p>
Dev ID	<p>Display of device generation</p>
Software rev	<p>Display of software version</p> <p>e.g.: 11 indicates version 1.1</p>
Product rev	<p>Display of unit version</p> <p>e.g.: 1.0000 indicates version 1.00.00</p>

1) Not for thermocouples (TC)

7.2.4 Supported HART® commands

No.	Description	Access
Universal Commands		
00	Read unique identifier	r
01	Read primary variable	r
02	Read p.v. current and percent of range	r

No.	Description	Access
03	Read dynamic variables and p.v. current	r
06	Write polling address	w
11	Read unique identifier associated with tag	r
12	Read message	r
13	Read tag, descriptor, date	r
14	Read primary variable sensor information	r
15	Read primary variable output information	r
16	Read final assembly number	r
17	Write message	w
18	Write tag, descriptor, date	w
19	Write final assembly number	w
Common practice		
34	Write primary variable damping value	w
35	Write primary variable range values	w
38	Reset configuration changed flag	w
40	Enter/Exit fixed primary variable current mode	w
42	Perform master reset	w
44	Write primary variable units	w
48	Read additional transmitter status	r
59	Write number of response preambles	w
108	Write burst mode command number	w
109	Burst mode control	w
Specific		
144	Read matrix parameter	r
145	Write matrix parameter	w

8 Diagnostics and troubleshooting

8.1 General troubleshooting

If faults occur after commissioning or during measurement, always start any trouble-shooting sequence using the following check. The user is led towards the possible fault cause and its rectification via question and answer.

8.2 Application fault messages

Application fault messages are shown in the display of the 'HART® Communicator' once the menu point "ERROR CODE" has been selected.



Fault code	Cause	Action/cure
0	No fault, Warning	None
10	Hardware fault (unit defective)	Replace DIN rail transmitter
11	Sensor short circuit	Check sensor
12	Sensor cable open circuit	Check sensor
13	Reference measurement point defective	None
14	Unit not calibrated	Return DIN rail transmitter to manufacturer
106	Up-/Download active	None (will be automatically acknowledged)
201	Warning: Measured value too small	Enter other values for measured value range start
202	Warning: Measured value too large	Enter other values for measured value range end
203	Unit is reset (to factory default settings)	None

8.3 Application faults without messages

General application faults



Problem	Possible cause	Remedy
No communication	No power supply on 2 wire circuit	Check current loop
	Power supply too low (< 11.5 V)	Connect cables correctly to terminal plan (polarity)
	Defective interface cable	Check interface cable
	Defective interface	Check PC interface
	Defective DIN rail transmitter	Replace DIN rail transmitter

Application faults for RTD connection (Pt100/Pt500/Pt1000/Ni100)

Problem	Pausable cause	Remedy
Fault current (≤ 3.6 mA or ≥ 21 mA)	Defective sensor	Check sensor
	Incorrect RTD connection	Reconnect cables correctly (connection diagram)
	Incorrect 2 wire connection	Connect cables correctly to terminal plan (polarity)
	Transmitter programming faulty (wire number)	Change parameter 'CONNECTION' (See "Description of unit functions" on →  18)
	Programming	Thermocouple set up (See "Description of unit functions" on →  18); change to RTD

Problem	Pausible cause	Remedy
	Defective DIN rail transmitter	Replace DIN rail transmitter
Measured value incorrect/inaccurate	Faulty sensor installation	Install sensor correctly
	Heat conducted via sensor	Take note of sensor installation length
	Transmitter programming faulty (wire number)	Change parameter 'Connection type'
	Transmitter programming faulty (scale)	Change scale
	Wrong RTD used	Change parameter 'Sensor type'
	Sensor connection (2 wire)	Check sensor connections
	Sensor cable (2 wire) not compensated	Compensate cable resistance
	Offset incorrectly set	Check offset

Application faults for TC connection

Problem	Pausible cause	Remedy
Fault current (≤ 3.6 mA or ≥ 21 mA)	Sensor incorrectly connected	Connect sensor correctly to terminal plan (polarity)
	Defective sensor	Replace sensor
	Programming	Sensor type 'RTD' setup; set up correct thermocouple
	Incorrect 2 wire connection (current loop)	Connect the cables correctly (see connection diagram)
	Defective DIN rail transmitter	Replace DIN rail transmitter
Measured value incorrect/inaccurate	Faulty sensor installation	Install sensor correctly
	Heat conducted via sensor	Take note of sensor installation length
	Transmitter programming faulty (scale)	Change scale
	Incorrect thermocouple setup	Change parameter 'Sensor type'
	Incorrect cold junction setup	See chapter →  15'Operation' and →  26
	Offset incorrectly set up	Check offset
	Fault on the thermowell welded thermo wire (coupling of interference voltages)	Use sensor where the thermo wire is not welded

8.4 Firmware history

Revision history

The firmware version (FW) on the nameplate and in the Operating Instructions indicates the device release: XX.YY.ZZ (example 01.02.01).

- XX Change to main version. No longer compatible. The device and Operating Instructions change.
- YY Change to functions and operation. Compatible. The Operating Instructions change.
- ZZ Fixes and internal changes. No changes to the Operating Instructions.

Date	Firmware version	Changes	Documentation
10/2001	01.01.zz	Original firmware	BA01854T/09/en/03.19

9 Repair

Repair is not envisaged for this measuring device.

9.1 Spare parts

Spare parts currently available for the device can be found online at:

http://www.products.endress.com/spareparts_consumables. Always quote the serial number of the device when ordering spare parts!

Type	Order number
Commubox FXA195 HART [®] , for intrinsically safe HART [®] communication with FieldCare via the USB interface.	FXA195-...

9.2 Return

The requirements for safe device return can vary depending on the device type and national legislation.

1. Refer to the website for more information:
<http://www.endress.com/support/return-material>
2. Return the device if repairs or a factory calibration are required, or if the wrong device was ordered or delivered.

9.3 Disposal



If required by the Directive 2012/19/EU on waste electrical and electronic equipment (WEEE), our products are marked with the depicted symbol in order to minimize the disposal of WEEE as unsorted municipal waste. Such products may not be disposed of as unsorted municipal waste and can be returned to Endress+Hauser for disposal at conditions stipulated in our General Terms and Conditions or as individually agreed.

10 Maintenance

The DIN rail temperature transmitter has no moving parts and requires minimal scheduled maintenance.

Sensor Checkout

To determine whether the sensor is at fault, replace it with another sensor or connect a test sensor locally at the transmitter to test remote sensor wiring. Select any standard, off-the-shelf sensor for use with a DIN rail temperature transmitter, or consult the factory for a replacement special sensor or transmitter combination.

11 Accessories

Various accessories, which can be ordered with the device or subsequently from Endress+Hauser, are available for the device. Detailed information on the order code in question is available from your local Endress+Hauser sales center or on the product page of the Endress+Hauser website: www.endress.com.

PC configuration software. Please contact your supplier when ordering!

12 Technical data

12.1 Input

12.1.1 Measured variable

Temperature (temperature-linear transmission behavior), resistance and voltage.

12.1.2 Measuring range

Depending upon the sensor connection and input signal. The transmitter evaluates a number of different measurement ranges.

12.1.3 Type of input

	Description	Measuring range limits	Min. span
Resistance thermometer (RTD)	Pt100 Pt500 Pt1000 acc. to IEC 751 ($\alpha = 0.00835$) Pt100 acc. to JIS C 1604-81 ($\alpha = 0.003916$)	-200 to +850 °C (-328 to +1562 °F) -200 to +250 °C (-328 to +482 °F) -200 to +250 °C (-328 to +482 °F) -200 to +649 °C (-328 to +1200 °F)	10 K (18 °F) 10 K (18 °F) 10 K (18 °F) 10 K (18 °F)
	Ni100 Ni500 Ni1000 acc. to DIN 43760 ($\alpha = 0.006180$)	-60 to +250 °C (-76 to +482 °F) -60 to +150 °C (-76 to +302 °F) -60 to +150 °C (-76 to +302 °F)	10 K (18 °F) 10 K (18 °F) 10 K (18 °F)
	<ul style="list-style-type: none"> ■ Connection type: 2-, 3- or 4-wire connection ■ Software compensation of cable resistance possible in the 2-wire system (0 to 30 Ω) ■ Sensor cable resistance max. 40 Ω per cable ■ Sensor current: ≤ 0.2 mA 		
Resistance transmitter	Resistance Ω	10 to 400 Ω 10 to 2000 Ω	10 Ω 100 Ω
Thermocouples (TC)	B (PtRh30-PtRh6) C (W5Re-W26Re) ¹⁾ D (W3Re-W25Re) ¹⁾ E (NiCr-CuNi) J (Fe-CuNi) K (NiCr-Ni) L (Fe-CuNi) ²⁾ N (NiCrSi-NiSi) R (PtRh13-Pt) S (PtRh10-Pt) T (Cu-CuNi) U (Cu-CuNi) ²⁾ acc. to IEC 584 Part1	+40 to +1820 °C (104 to +3308 °F) 0 to +2320 °C (+32 to +4208 °F) 0 to +2495 °C (+32 to +4523 °F) -270 to +1000 °C (-454 to +1832 °F) -210 to +1200 °C (-346 to +2192 °F) -270 to +1372 °C (-454 to +2501 °F) -200 to +900 °C (-328 to +1652 °F) -270 to +1300 °C (-454 to +2372 °F) -50 to +1768 °C (-58 to +3214 °F) -50 to +1768 °C (-58 to +3214 °F) -279 to +400 °C (-454 to +752 °F) -200 to +600 °C (-328 to +1112 °F)	500 K (900 °F) 500 K (900 °F) 500 K (900 °F) 50 K (90 °F) 50 K (90 °F) 50 K (90 °F) 50 K (90 °F) 50 K (90 °F) 50 K (90 °F) 500 K (900 °F) 500 K (900 °F) 50 K (90 °F) 50 K (90 °F)
	<ul style="list-style-type: none"> ■ Cold junction internal (Pt100) ■ Cold junction accuracy: ± 1 K 		
Voltage transmitters	Millivolt transmitter	-10 to 75 mV	+5 mV

1) According to ASTM E988

2) According to DIN 43710

12.2 Output

12.2.1 Output signal

Output signal	4 to 20 mA, 20 to 4 mA
Signal on alarm	<ul style="list-style-type: none"> ■ Measurement range undercut: Linear drop to 3.8 mA ■ Exceeding measurement range: Linear drop to 20.5 mA ■ Sensor breakage; Sensor short circuit (not for thermocouples TC): ≤3.6 mA or ≥ 21.0 mA (for configuration ≥ 21.0 mA, output is ≥ 21.5 mA)
Load	Max. $(V_{\text{Power supply}} - 12 \text{ V}) / 0.022 \text{ A}$ (Current output)
Linearization / transmission behaviour	Temperature linear, resistance linear, voltage linear
Filter	Digital filter 1. degree: 0 to 100 s
Galvanic isolation	U = 2 kV AC for 1 minute (Input/output)
min. current consumption	≤ 3,5 mA
Current limit	≤ 23 mA
Switch on delay	4 s (during power up I _a 3.8 mA)

12.3 Power supply

12.3.1 Electrical connection

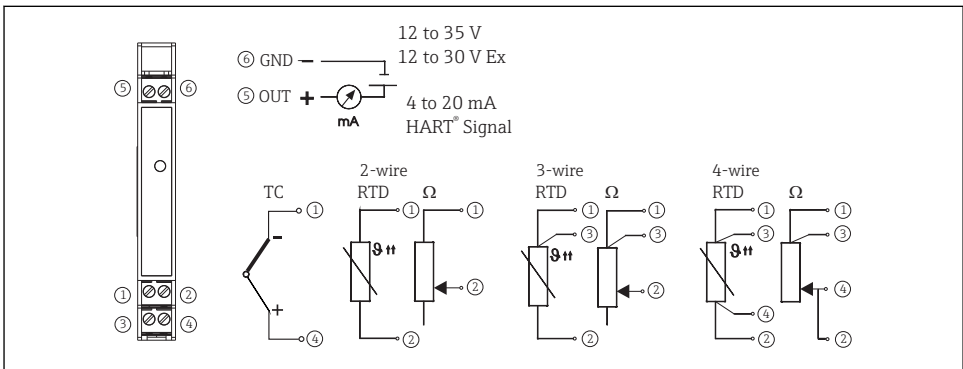

A0040217

6 Temperature transmitter terminal connections

For the unit operation via HART® protocol (terminals 5 and 6) a minimum load resistance of 250 Ω is necessary in the signal circuit!

12.3.2 Supply voltage

Values for non-hazardous areas, protected against polarity reversal:
DIN rail device 12 to 35 V

12.3.3 Residual ripple

Allowable ripple $U_{ss} \leq 3 \text{ V}$ at $U_b \geq 15 \text{ V}$, $f_{\max.} = 1 \text{ kHz}$

12.4 Performance characteristics

12.4.1 Response time

The measured value update depends on the type of sensor and connection method and moves within the following ranges:

Resistance thermometer (RTD)	1 s
------------------------------	-----

12.4.2 Reference operating conditions

Calibration temperature: $+25 \text{ °C} \pm 5 \text{ K}$ ($77 \text{ °F} \pm 9 \text{ °F}$)

12.4.3 Maximum measured error



The accuracy data are typical values and correspond to a standard deviation of $\pm 3 \sigma$ (normal tribution), i.e. 99.8% of all the measured values achieve the given values or better values.

	Type	Measurement accuracy ¹⁾
Resistance thermometer RTD	Pt100, Ni100 Pt500, Ni500 Pt1000, Ni1000	0.2 K or 0.08% 0.5 K or 0.20% 0.3 K or 0.12%
Thermocouple TC	K, J, T, E, L, U N, C, D R, S B	typ. 0.5 K or 0.08% typ. 1.0 K or 0.08% typ. 1.4 K or 0.08% typ. 2.0 K or 0.08%

1) % is related to the adjusted measurement range. The value to be applied is the greater.

	Measurement range	Measurement accuracy ¹⁾
Resistance thermometer Ω	10 to 400 Ω 10 to 2 000 Ω	$\pm 0.1 \Omega$ or 0.08% $\pm 1.5 \Omega$ or 0.12%
Voltage transmitter (mV)	-10 to 75 mV	20 mV or 0.08%

1) % is related to the adjusted measurement range. The value to be applied is the greater.

Physical input measuring range of sensors	
10 to 400 Ω	Polynom RTD, Pt100, Ni100

10 to 2000 Ω	Pt500, Pt1000, Ni1000
-10 to 75 mV	Thermocouple type: C, D, E, J, K, L, N, U
-10 to 35 mV	Thermocouple type: B, R, S, T

12.4.4 Influence of power supply

Sensor input: < 0,003%/V from measurement

Current output: < 0,007%/V of the adjusted measuring span

12.4.5 Influence of ambient temperature (temperature drift)

Total temperature drift = input temperature drift + output temperature drift

Effect on the accuracy when ambient temperature changes by 1 K (1.8 °F):	
Input 10 to 400 Ω	typ. 0.0015% of measured value, min. 4 mΩ
Input 10 to 2000 Ω	typ. 0.0015% of measured value, min. 20 mΩ
Input -10 to 75 mV	typ. 0.005% of measured value, min. 1.2 μV
Input -10 to 35 mV	typ. 0.005% of measured value, min. 0.6 μV
Output 4 to 20 mA	typ. 0.005% of span

Typical sensitivity of resistance thermometers:	
Pt: 0.00385 * R _{nominal} /K	Ni: 0.00617 * R _{nominal} /K

Example Pt100: 0.00385 x 100 Ω/K = 0.385 Ω/K

Typical sensitivity of thermocouples:					
B: 10 μV/K	C: 20 μV/K	D: 20 μV/K	E: 75 μV/K	J: 55 μV/K	K: 40 μV/K
L: 55 μV/K	N: 35 μV/K	R: 12 μV/K	S: 12 μV/K	T: 50 μV/K	U: 60 μV/K

Example for calculating measured error for ambient temperature drift:

Input temperature drift ΔT= 10 K (18 °F), Pt100, measuring range 0 to 100 °C (32 to 212 °F)

Maximum process temperature: 100 °C (212 °F)

Measured resistance value: 138.5 Ω (IEC 60751) at maximum process temperature

Typical temperature drift in Ω: (0.0015% of 138.5 Ω) * 10 = 0.02078 Ω

Conversion to Kelvin: 0.02078 Ω / 0.385 Ω/K = 0.05 K (0.09 °F)

12.4.6 Influence of load

≤ ± 0.02%/100 Ω

Values refer to the full scale value

12.4.7 Long term stability

$\leq \pm 0.1\text{K/year}$ or $\leq 0.05\%/year$

Values under reference operating conditions. % refer to the set span. The highest value is valid.

12.4.8 Influence of cold junction

Pt100 DIN IEC 60751 Cl. B (internal cold junction with thermocouples TC)

12.5 Installations condistions

12.5.1 Installation instructions

Orientation

When using DIN rail transmitters with a thermocouple/mV measurement, increased measurement deviations may occur if the transmitter is mounted in series between other DIN rail devices.

12.6 Environment

12.6.1 Ambient temperature range

-40 to +85 °C (-40 to +185 °F), for Ex-areas see Ex-certification

12.6.2 Storage temperature

-40 to +100 °C (-40 to +212 °F)

12.6.3 Humidity

Permitted

12.6.4 Climate class

As per IEC 60 654-1, Class C

12.6.5 Degree of protection

IP 20 (NEMA 1)

12.6.6 Shock and vibration resistance

4 g / 2 to 150 Hz as per IEC 60 068-2-6

12.6.7 Electromagnetic compatibility (EMC)

CE compliance

Electromagnetic compatibility in accordance with all the relevant requirements of the IEC/EN 61326 series and NAMUR Recommendation EMC (NE21). For details, refer to the Declaration of Conformity.

Maximum measured error <1% of measuring range.

Interference immunity as per IEC/EN 61326 series, industrial requirements

Interference emission as per IEC/EN 61326 series, Class B equipment

12.7 Mechanical construction

12.7.1 Design, dimensions

Dimensions in mm (in)

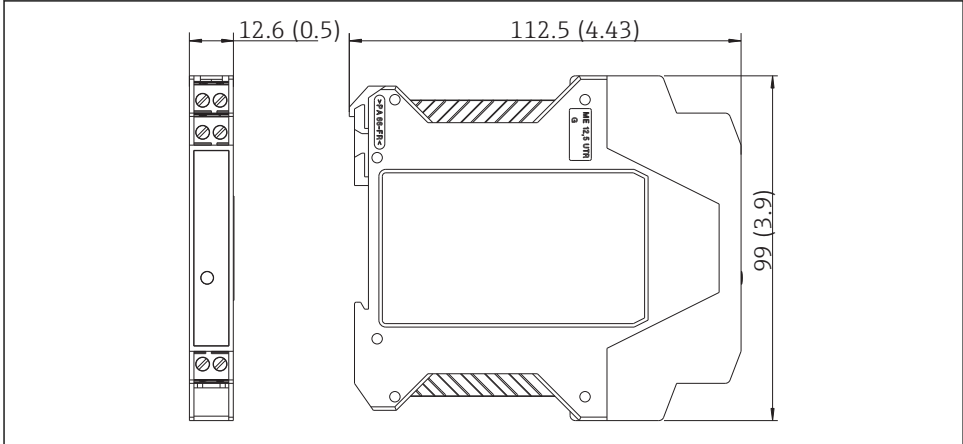

A0040222

7

12.7.2 Weight

Head transmitter: approx. 90 g (3.2 oz)

12.7.3 Materials

- Housing: Plastic Polycarbonate (PC)/ABS, UL 94V0
- Terminals: Keyed plug-in screw terminals, core size max. 16 AWG solid, or strands with ferrules.

12.8 Human interface

12.8.1 Display elements

A yellow illuminated LED signalizes: Device is operational. With the PC software ReadWin® 2000 or FieldCare the current measured value can be displayed.

12.8.2 Operating elements

At the temperature transmitter no operating elements are available directly. The temperature transmitter will be configured by remote operation with the PC software ReadWin® 2000 or FieldCare.

12.8.3 Remote operation

Configuration

HART® communicator or PC with Commubox FXA195 and operating software (ReadWin® 2000 or FieldCare).

Interface

PC interface Commubox FXA195 (USB).

12.9 Certificates and approvals

12.9.1 CE mark

The product meets the requirements of the harmonized European standards. As such, it complies with the legal specifications of the EC directives. The manufacturer confirms successful testing of the product by affixing to it the CE-mark.

12.9.2 EAC conformity

The measuring system meets the legal requirements of the applicable EAC guidelines. These are listed in the corresponding EAC Declaration of Conformity together with the standards applied.

Endress+Hauser confirms successful testing of the device by affixing to it the EAC mark.

12.9.3 Hazardous area approvals

FM IS, Class I, Div. 1+2, Group A, B, C, D

CSA IS, Class I, Div. 1+2, Group A, B, C, D

ATEX II2(1) G EEx ia IIC T4/T5/T6

12.9.4 Other standards and guidelines

- IEC 60529:
Degree of protection provided by housing (IP code)
- IEC/EN 61010-1:
Safety requirements for electrical equipment for measurement, control and laboratory use
- IEC/EN 61326-Series:
Electromagnetic compatibility (EMC requirements)

www.addresses.endress.com
