

ARTICULO: 2528

Válvula de esfera paso total Bridada, Acero Inoxidable Stainless Steel full port ball valve, Flanged ends

Características

1. Válvula de esfera paso total, 2 piezas.
2. Extremos Bridados según EN 1092-1.
PN 40 desde DN 15 hasta DN 50.
PN 16 desde DN 65 hasta DN 200.
3. Construcción en Acero Inoxidable 1.4408 (CF8M).
4. Longitud entre caras según EN 558 serie 27.
5. Asientos PTFE + 15 % F.V.
(otro material consultar)
6. Junta cuerpo espirometálica desde DN 32.
7. Tórica en el eje de FKM (Viton).
8. Vástago inextinguible.
9. Montaje actuador directo según ISO 5211.
10. Sistema de bloqueo incorporado.
11. Dispositivo Anti-estático.
12. Diseño anti-fuego.
13. Presión de trabajo máxima 40 / 16 bar.
14. Temperatura de trabajo -30 °C + 180 °C.

Features

1. Full port ball valve, 2 pieces.
2. Flanged ends according to EN 1092-1.
PN 40 DN 15 to DN 50.
PN 16 DN 65 to DN 200.
3. Made of Stainless Steel 1.4408 (CF8M).
4. Face to Face according to EN 558 series 27.
5. Ball seats PTFE + 15 % G.F.
(please ask for other materials)
6. From DN 32 with spiral wound gasket..
7. FKM (Viton) stem O' ring.
8. Blow-out proof stem.
9. Direct mounting actuator according to ISO 5211.
10. Block System included.
11. Anti-static device.
12. Fire-safe design.
13. Max. Working pressure 40 / 16 bar.
14. Working Temperature -30 °C + 180 °C.

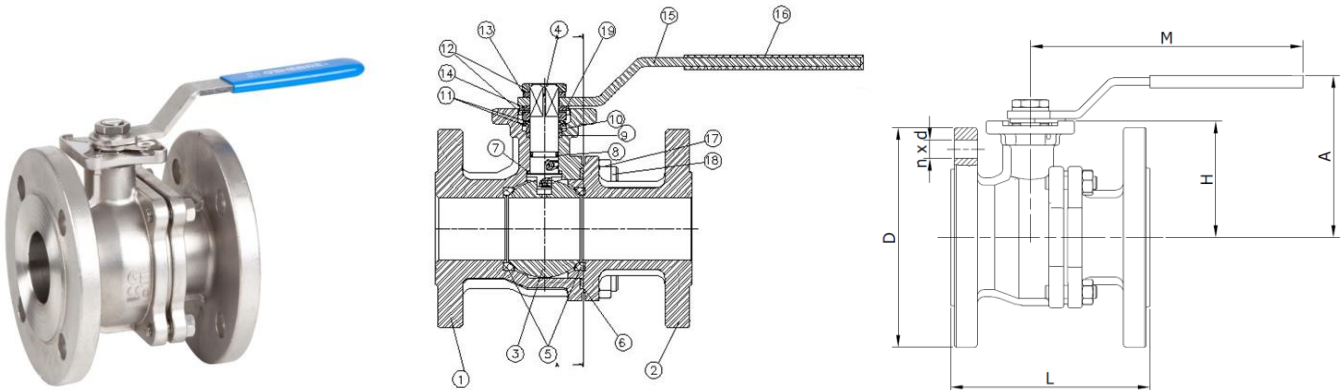

Nº	Denominación / Name	Material	Acabado Superficial / Surface Treatment	Cód. Recambio Spare Part Code
1	Cuerpo / Body	Acero Inox. / Stainless Steel 1.4408	Granallado / Shot blasting	-----
2	Tapa / Cap	Acero Inox. / Stainless Steel 1.4408	Granallado / Shot blasting	-----
3*	Bola / Ball	Acero Inox. / Stainless Steel 1.4408	Pulido / Polishing	2907
4*	Eje / Stem	Acero Inox. / Stainless Steel AISI 316	-----	2908
5*	Asiento / Ball Seat	PTFE+15% FV/GF	-----	2909
6*	Junta / Gasket	PTFE (hasta / until DN25) SS+Graphite (desde / from DN32)	-----	2909
7*	A. fricción / Thrust Washer	PTFE + grafito / graphite	-----	2909
8*	Tórica / O' ring	FKM	-----	2909

Nº	Denominación / Name	Material	Acabado Superficial / Surface Treatment	Cód. Recambio Spare Part Code
9*	Empaquetadura / Stem packing	PTFE	-----	2909
10	Anillo Prensa / Gland	Acero Inox. / Stainless Steel AISI 304	-----	-----
11	Arandela / Spring Washer	Acero Inox. / Stainless Steel AISI 301	-----	-----
12	Tuerca / Nut	Acero Inox. / Stainless Steel AISI 304	-----	-----
13	Arandela / Washer	Acero Inox. / Stainless Steel AISI 304	-----	-----
14	Tope / Stopper	Acero Inox. / Stainless Steel AISI 304	-----	-----
15	Maneta / Handle	Acero Inox. / Stainless Steel AISI 304	-----	-----
16	Funda / Handle Sleeve	Vynil	-----	-----
17	Tuerca / Nut	Acero Inox. / Stainless Steel AISI 304	-----	-----
18	Perno / Stud Bolt	Acero Inox. / Stainless Steel AISI 304	-----	-----
19	Antigiro / Lock Washer	Acero Inox. / Stainless Steel AISI 304	-----	-----

* Piezas de recambio disponibles / Available spare parts

Únicamente en medidas de 2 ½" a 8" / For 2 ½"–8" Sizes Only.

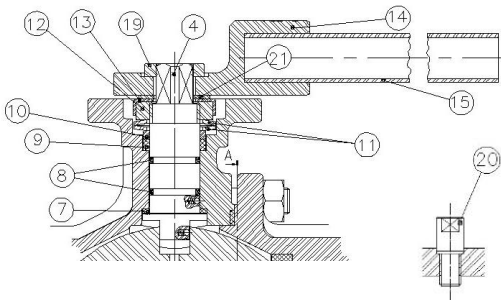

Nº	Denominación/Name	Material	Acabado Superficial/ Surface Treatment
14	Cuerpo maneta / Body Handle	1.4408	Granallado / Shot blasting
19	Tuerca / Nut	AISI 304	-----
20	Perno tope / Stopper	AISI 304	-----
21	Antigiro / Lock Washer	AISI 304	-----

Dispositivo Antiestático / Anti-static Device.

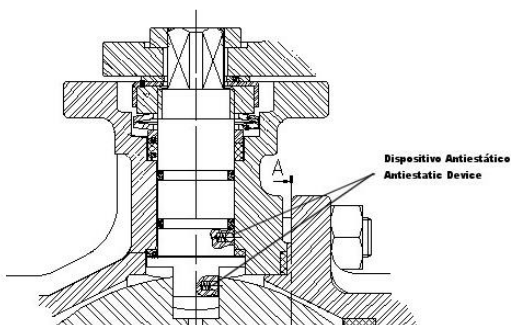

Este dispositivo nos garantiza la continuidad eléctrica entre esfera - eje - cuerpo, esto es de especial necesidad en fluidos inflamables. / This device provides Ball - Stem - Body electric continuity. It is specially required with flammable fluids.

Detalle de la zona de Eje / Stem detail

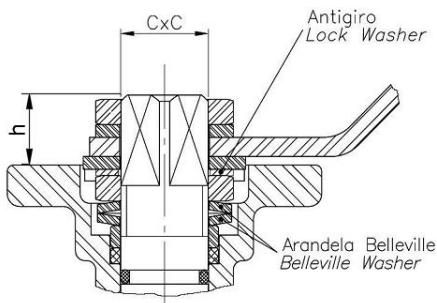

Antigiro / Lock Washer: Previene el desajuste de la tuerca del eje en elevados ciclos de maniobra / *Prevents unthreading of stem nut in high cycle automation applications.*

Arandela Belleville / Belleville Washer: Las arandelas belleville proporcionan una carga constante sobre el prensa asegurando un cierre firme en variaciones de condiciones de trabajo. / *Standard belleville washers provide constant "live load" on the stem seals, assuring a tight seal even varying service parameters*

DIMENSIONES GENERALES / GENERAL DIMENSIONS

Ref.	Medida / Size	PN	Dimensiones/Dimensions (mm)									Peso/ Weight (Kg)
			D	A	L	M	n x d	ISO 5211	H	h	C x C	
2528 04	1/2"	40	95	85	115	170	4 x 14	F04	46	9,5	9 x 9	2,200
2528 05	3/4"	40	105	85	120	170	4 x 14	F04/F05	51	10	9 x 9	3,050
2528 06	1"	40	116	95	125	170	4 x 14	F04/F05	57	11	11 x 11	3,750
2528 07	1 1/4"	40	140	106	130	200	4 x 18	F05/F07	71	15,5	14 x 14	5,750
2528 08	1 1/2"	40	150	110	140	200	4 x 18	F05/F07	76	15,5	14 x 14	7,000
2528 09	2"	40	165	118	150	200	4 x 18	F05/F07	83	15,5	14 x 14	9,500
2528 10	2 1/2"	16	185	170	170	380	4 x 18	F07/F10	119	21	17 x 17	14,750
2528 11	3"	16	200	170	180	380	8 x 18	F07/F10	130	21	17 x 17	18,850
2528 12	4"	16	220	170	190	380	8 x 18	F07/F10	145	21	17 x 17	26,250
2528 13	5"	16	250	200	325	520	8 x 18	F10/F12	163	34	27 x 27	38,000
2528 14	6"	16	285	220	350	620	8 x 22	F10/F12	180	34	27 x 27	51,000
2528 16	8"	16	340	334	400	800	12 x 22	F12	253	27	27 x 27	119,500

CURVA PRESIÓN TEMPERATURA / PRESSURE TEMPERATURE RATING

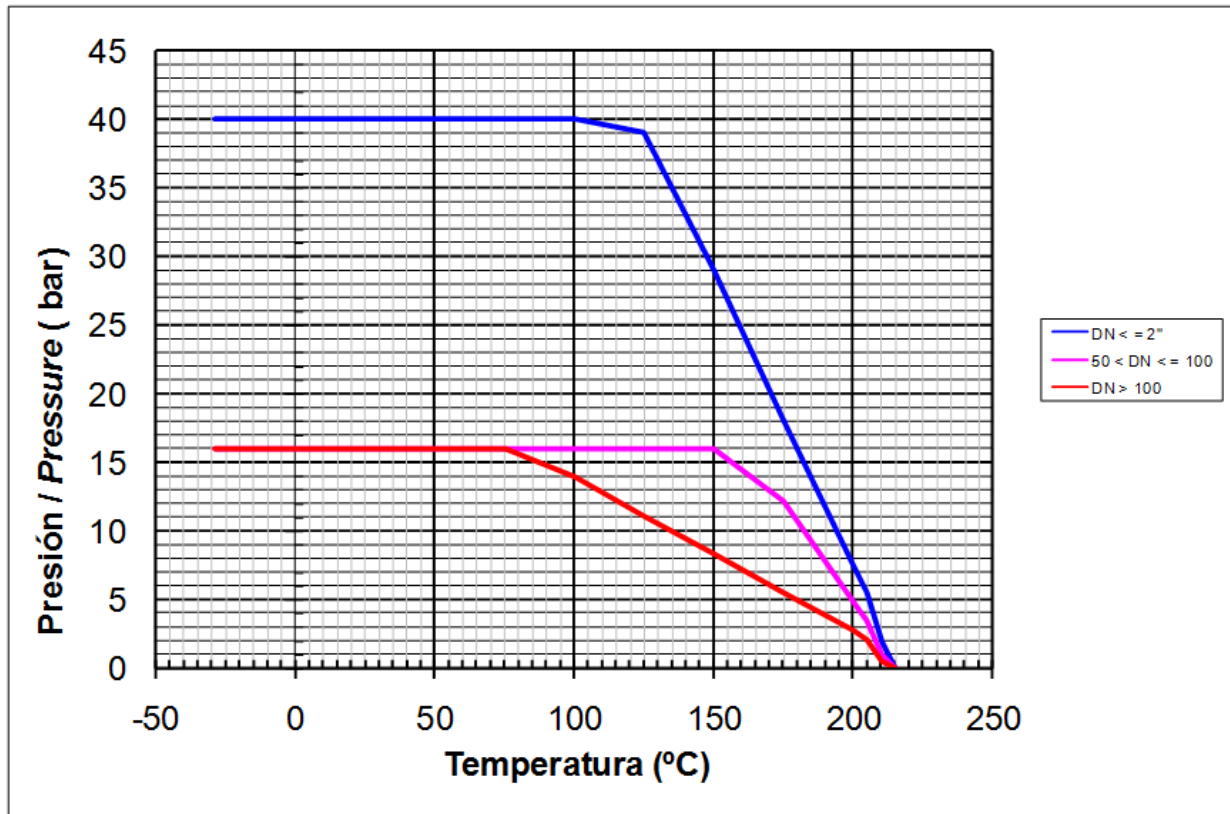

(1 bar = 0,1 MPa ; 1 MPa = 1 N/mm²)

VALORES DE Kv / Kv VALUES

Kv = Es la cantidad de metros cúbicos por hora (m³/h) que pasará a través de la válvula generando una pérdida de carga de 1 bar.

Kv = Flow rate of water in cubic meter per hour (m³/h) generating a pressure drop of 1 bar across the valve.

1/2"	3/4"	1"	1 1/4"	1 1/2"	2"	2 1/2"	3"	4"	5"	6"	8"
19	40	65	110	180	365	495	970	1620	2530	4050	8650

DIAGRAMA DE PERDIDA DE CARGA / HEADLOSS CHART
VÁLVULAS PASO TOTAL BRIDADAS / FLANGED ENDS FULL BORE BALL VALVES

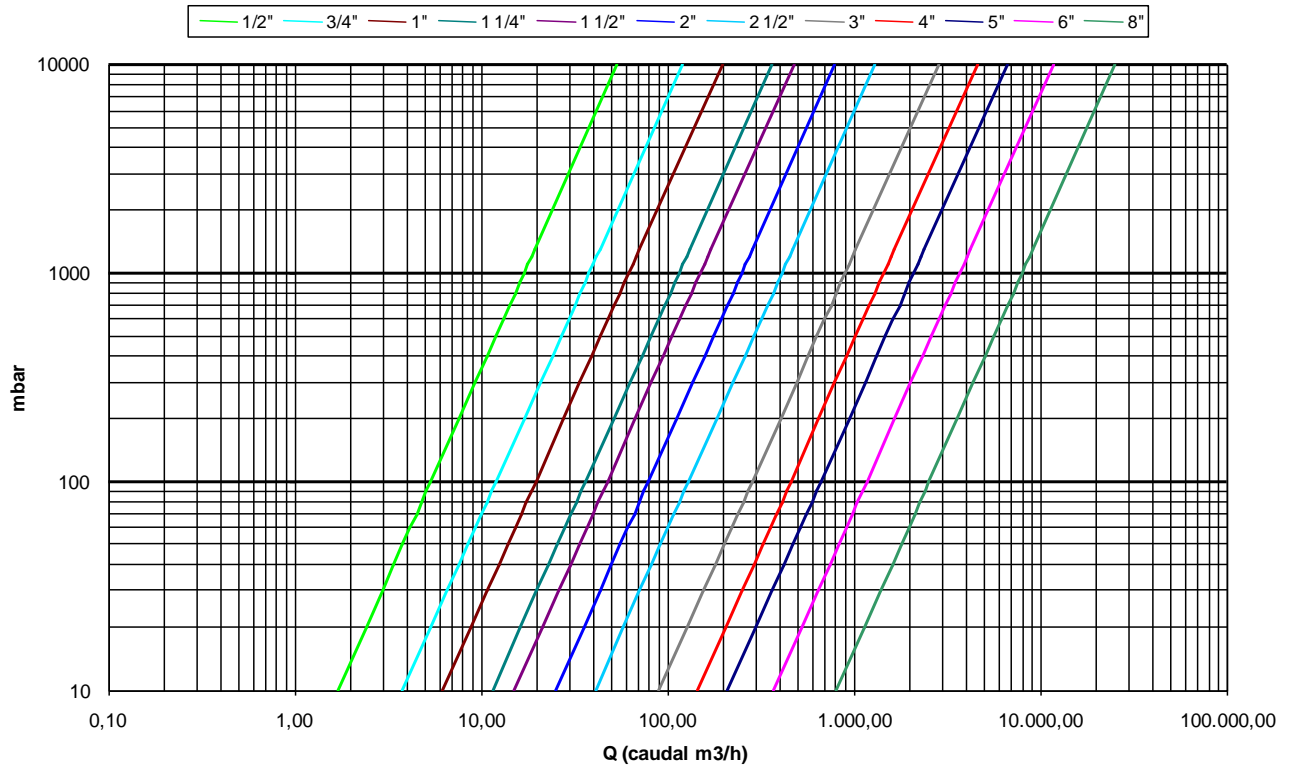

DECLARACIÓN DE CONFORMIDAD CE

GENEBRE, S.A.

Av. Juan Carlos I, 46-48 – EDIFICIO GENE BRE
08908 L'HOSPITALET DE LLOBREGAT (BCN)

DECLARA bajo su única responsabilidad, que el producto suministrado:

Válvula de esfera paso total Bridada Art. 2528

es conforme con los Requisitos Esenciales de Seguridad establecidos en el Anexo II de la Directiva 2014/34/UE.

Para el cumplimiento de los requisitos, el producto es conforme con las normas:

- UNE-EN 13463-1: 2009
- UNE-EN 13463-5: 2003

El modelo dispone de un EXPEDIENTE TÉCNICO EN CUSTODIA nº LOM 11ATEX0067, y ha sido fabricado en:

GENEBRE, S.A.

Av. Juan Carlos I, 46-48 – EDIFICIO GENE BRE
08908 L'HOSPITALET DE LLOBREGAT (BCN)

Lo que le autoriza a colocar sobre el producto el marcado legal:

CE  **II 2 GD c T6 - T3/125 °C**

Fecha: 10 Noviembre de 2011

Firma:  A. Martinez Romay

Director de Producto, División Industrial

“CE” DECLARATION OF CONFORMITY

GENEBRE, S.A.

Av. Juan Carlos I, 46-48 – EDIFICIO GENE BRE
08908 L'HOSPITALET DE LLOBREGAT (BCN)

DECLARES under its own responsibility that the supplied product:

Full Port Ball Valve Flanges ends Art. 2528

Is in accordance with the Essential Safety Requirements established in Annex II of the 2014/34/EU Directive.

For the fulfillment of the requirements, the product is according to the standards:

- UNE-EN 13463-1: 2009
- UNE-EN 13463-5: 2003

Technical Custody File nº LOM 11ATEX0067.

The product has been manufactured in

GENEBRE, S.A.

Av. Juan Carlos I, 46-48 – EDIFICIO GENE BRE
08908 L'HOSPITALET DE LLOBREGAT (BCN)

who has the authorization to mark the product as following:

CE  **II 2 GD c T6 - T3/125 °C**

Date: November 10th, 2011

Sign:  **A. Martinez Romay**

Product Manager, Industrial Division