

Altistart 48

Guide d'exploitation
User manual
Benutzerhandbuch
Guía de explotación
Guida all'impiego
用户手册

12/2012



Démarrateurs-ralentisseurs progressifs,
Soft start- soft stop units,
Sanftanlasser,
Arrancadores, ralentizadores
progresivos,
Avviatori-rallentatori progressivi,
软起动器

Altistart 48

Démarreurs-ralentisseurs progressifs

5

FRANÇAIS

Soft start-soft stop units

87

ENGLISH

Sanftanlasser

169

DEUTSCH

Arrancadores, ralentizadores progresivos

251

ESPAÑOL

Avviatori-rallentatori progressivi

333

ITALIANO

中文

页 415

中文

As a rule, the Altistart 48 control (CL1 - CL2) and power (1/L1 - 3/L2 - 5/L3) supplies must be disconnected before any operation on either the electrical or mechanical parts of the installation or machine.

During operation the motor can be stopped by cancelling the run command. The starter remains powered up. If personnel safety requires prevention of sudden restarts, this electronic locking system is not sufficient: fit a breaker on the power circuit.

The starter is fitted with safety devices which, in the event of a fault, can stop the starter and consequently the motor. The motor itself may be stopped by a mechanical blockage. Finally, voltage variations or line supply failures can also cause shutdowns.

If the cause of the shutdown disappears, there is a risk of restarting which may endanger certain machines or installations, especially those which must conform to safety regulations.

In this case the user must take precautions against the possibility of restarts, in particular by using a low speed detector to cut off power to the starter if the motor performs an unprogrammed shutdown.

The products and equipment described in this document may be changed or modified at any time, either from a technical point of view or in the way they are operated. Their description can in no way be considered contractual.

This starter must be installed and set up in accordance with both international and national standards. Bringing the device into conformity is the responsibility of the systems integrator who must observe the EMC directive among others within the European Union.

The specifications contained in this document must be applied in order to comply with the essential requirements of the EMC directive.

The Altistart 48 must be considered as a component: it is neither a machine nor a device ready for use in accordance with European directives (machinery directive and electromagnetic compatibility directive). It is the responsibility of the final integrator to guarantee conformity to the relevant standards.

Contents

Steps for setting up the starter _____	88
Factory configuration _____	90
Preliminary recommendations _____	91
Technical specifications _____	92
Operating recommendations _____	93
Starter-motor combinations _____	96
Dimensions _____	102
Mounting recommendations _____	104
Mounting in a wall-fixing or floor-standing enclosure _____	105
Power terminals _____	106
Control terminals _____	111
Wiring/RUN - STOP commands _____	112
Application diagram _____	113
Thermal protection _____	123
Display unit and programming _____	127
Remote terminal option _____	130
Settings menu (Set) _____	131
Protection menu (PrO) _____	136
Advanced settings menu (drC) _____	140
I/O menu (IO) _____	144
2nd motor parameters menu (St2) _____	148
Communication menu (COP) _____	152
Parameter displayed menu (SUP) _____	154
Compatibility table _____	157
Maintenance _____	158
Faults - causes - remedies _____	159
Configuration/Settings tables _____	165

Steps for setting up the starter

1 - Check the delivery of the Altistart 48

- Check that the starter reference printed on the label is the same as that on the delivery note corresponding to the purchase order.
- Remove the Altistart 48 from its packaging and check that it has not been damaged in transit.

⚠ WARNING

DAMAGED SOFT STARTER EQUIPMENT

Do not operate or install any soft starter or soft starter accessory that appears damaged.

Failure to follow these instructions can result in death, serious injury or equipment damage.

2 - Mount the soft starter vertically

- Fit the Altistart 48 in accordance with the recommendations on [page 104](#) and [page 105](#).

3 - Connect the Altistart 48:

- Wire the soft starter to the ground.
- The control line supply (CL1 – CL2), ensuring that it is off
- The power line supply (1/L1 - 3/L2 - 5/L3), ensuring that it is off
- The motor (2/T1 - 4/T2 - 6/T3), ensuring that its coupling corresponds to the supply voltage

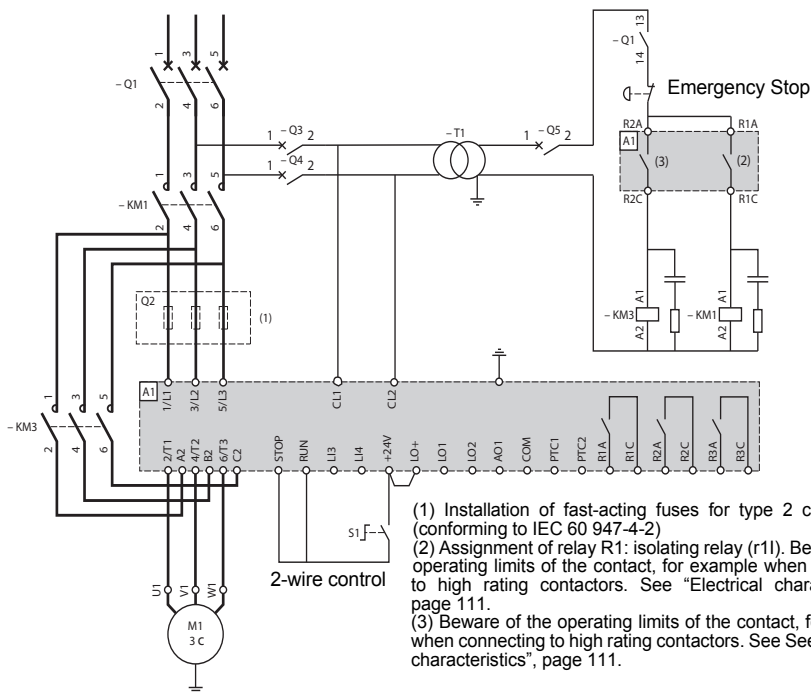

Note: For other wiring diagrams, see [page 113](#) to [page 117](#).

If the ATS48●●●Q / ATS48●●●YS316 is used in the motor delta windings, follow the recommendations on [page 94](#), [page 95](#) and the diagrams on [page 115](#).

Steps for setting up the starter

4 - Powering up the control part (CL1-CL2)

- Powering up without the power part and without giving the run command.
- Check that S1 is open.
- Switch on: Q1, then Q3, then Q4.
- The starter displays: nLP (to indicate that the power is switched off).

CAUTION

RISK OF DAMAGE TO THE SOFT STARTER

- Check the power supply on CL1 - CL2:
ATS48●●●Q must be 220 - 415 V AC
ATS48●●●Y must be 110 - 230 V AC
- Failure to follow these instructions can result in equipment damage**

5 - Adjust I_n nominal motor current

- See Nominal Motor Current on Motor Nameplate

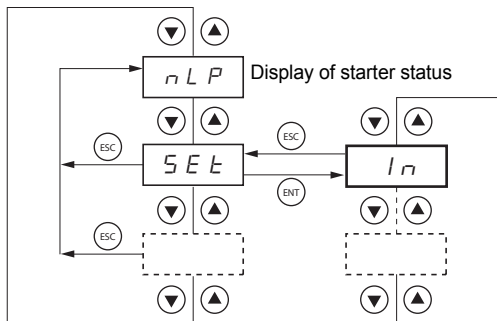

6 - Powering up the power part (1/L1 - 3/L2 - 5/L3)

- Switch on: Q5.
- The soft starter displays: r d Y (to indicate that the starter is powered up and ready).

7 - Start the motor

- Push S1, the motor starts

8 - Troubleshooting information

- See Faults - causes - remedies [page 159](#)

CAUTION

MOTOR OVERHEATING HAZARD

The ATS 48 starter is factory-configured for a standard application which does not require specific functions. It has motor protection class 10.

The settings can be changed by accessing the parameters as described [on page 128](#).

In all cases the I_n parameter must be set to the current value indicated on the motor rating plate.

Failure to follow these instructions can result in equipment damage

Factory settings

The Altistart 48 is factory-set for the most common operating conditions:

- The ATS 48 is used on the motor line supply (it is not inserted as a delta connection in the motor windings)
- Nominal motor current I_n :
 - ATS 48 ***Q: preset for a standard 400 V 4-pole motor
 - ATS 48 ***Y: preset for NEC current, 460 V motor
- Limiting current (ILt): 400% of the motor current I_n
- Acceleration ramp (ACC): 15 seconds
- Initial torque on starting (tq_0): 20% of the nominal torque
- Stop (StY): Freewheel stop (-F-)
- Motor thermal protection (tHP): class 10 protection curve
- Display: rdY (starter ready) with power and control voltage present, motor current operating
- Logic inputs:
 - LI1: STOP
 - LI2: RUN
 - LI3: Forced freewheel stop (LIA)
 - LI4: Forced local mode (LIL)
- Logic outputs:
 - LO1: Motor thermal alarm (tA1)
 - LO2: Motor powered (ml)
- Relay outputs:
 - R1: Fault relay (r1l)
 - R2: Bypass relay at the end of starting
 - R3: Motor powered (ml)
- Analog output:
 - AO: Motor current (OCr, 0 - 20 mA)
- Communication parameters:
 - Connected via the serial link, the starter has the logic address (Add) = "0"
 - Transmission speed (tbr): 19200 bits per second
 - Communication format (FOr): 8 bits, no parity, 1 stop bit (8nl)

If the above values are compatible with the application, the starter can be used without changing the settings.

Preliminary recommendations

Handling and storage

To ensure the starter is protected before installation, handle and store the device in its packaging.

Handling on installation

The Altistart 48 range comprises 6 sizes of device, with various weights and dimensions.

Small starters can be removed from their packaging and installed without a handling device.

A handling device must be used with large starters; for this reason they are supplied with handling "lugs". The precautions described below must be observed:

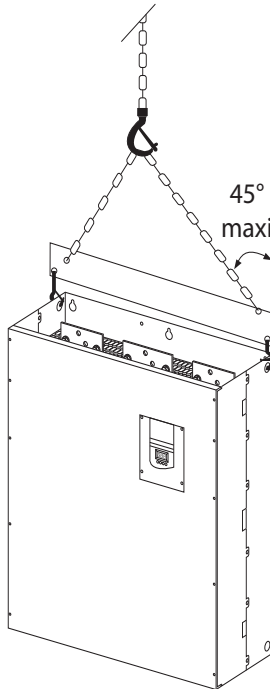

Do not handle the starter by the power rails

Technical specifications

Environment

Degree of protection	<ul style="list-style-type: none">• IP 20 for ATS 48D17• to C11•• IP00 for ATS 48C14• to M12• (1)
Vibration resistance	Conforming to IEC 68-2-6: <ul style="list-style-type: none">• 1.5 mm peak from 2 to 13 Hz• 1 gn from 13 to 200 Hz
Shock resistance	Conforming to IEC 68-2-27: <ul style="list-style-type: none">• 15 g, 11 ms
Maximum ambient pollution	Degree 3 conforming to IEC 947-4-2
Maximum relative humidity	93% without condensation or dripping water conforming to IEC 68-2-3
Ambient temperature around the unit	Storage: - 25 °C to + 70 °C Operation: <ul style="list-style-type: none">• - 10 °C to + 40 °C without derating• up to +60 °C, derating the current by 2% for each °C above 40 °C
Maximum operating altitude	1000 m without derating (above this, derate the current by 2 % for each additional 100 m)
Operating position	Vertical at ± 10°



(1) ATS 48 starters with degree of protection IP00 must be fitted with a protective bar to protect personnel against electrical contact

Available torque

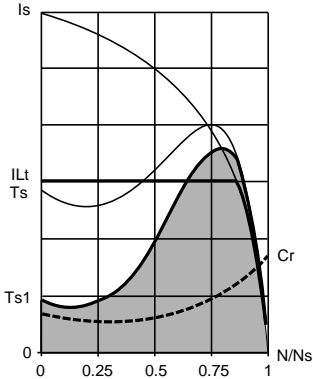

Curves T_s and I_s represent the direct line starting of an asynchronous motor.

Curve T_{a1} indicates the total torque range available with an ATS 48, which is dependent on the limiting current I_{Lt} . The progression of the starter is controlled by the motor torque within this range.

T_r : Resistive torque, which must always be less than the T_{s1} torque.

Selecting the soft start - soft stop unit

S1 motor duty corresponds to starting followed by operation at constant load enabling the thermal equilibrium to be reached.

S4 motor duty corresponds to a cycle comprising starting, operation at constant load and an idle period. This cycle is characterised by a load factor.

The Altistart 48 must be selected depending on the type of application ("standard" or "severe") and the nominal power of the motor. "Standard" or "severe" applications define the limiting values of the current and the cycle for motor duties S1 and S4.



Caution: Do not use the Altistart 48 upstream of loads other than motors (for example transformers and resistors are forbidden). Do not connect power factor correction capacitors to the terminals of a motor controlled by an Altistart 48

Standard application

Example: centrifugal pump

In standard applications, the Altistart 48 is designed to provide:

- in S1 duty: starting at 4 I_n for 23 seconds or starting at 3 I_n for 46 seconds from a cold state.
- in S4 duty: a load factor of 50% and 10 starts per hour, with 3 I_n for 23 seconds or 4 I_n for 12 seconds or an equivalent thermal cycle.

In this case, the motor thermal protection must conform to protection class 10.

Severe application

Example: grinder

In severe applications, the Altistart 48 is designed for S4 duty with a load factor of 50% and 5 starts per hour at 4 I_n for 23 seconds or an equivalent thermal cycle.

In this case, the motor thermal protection must conform to protection class 20. Current **in must not remain at its factory setting** but must be set to the value indicated on the motor rating plate.

Note: The starter can be oversized by one rating, for example by selecting an ATS 48D17Q for an 11 kW - 400 V motor in motor duty S4.

To do this, short-circuit the Altistart at the end of starting. This permits 10 starts per hour at 3 times I_n for 23 seconds maximum or equivalent and the thermal motor protection must conform to class 10.

Operating recommendations

The Altistart 48 Q range (230-415 V) connected in line with the motor or in the motor delta winding

The Altistart 48 connected in the motor supply line

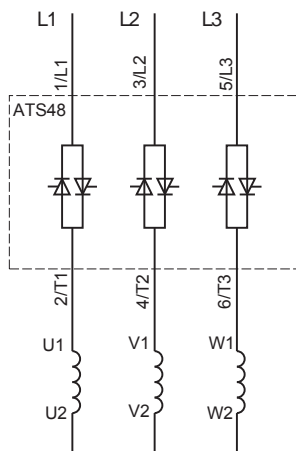

The motor connection depends on the supply voltage, which in this example is a star connection.

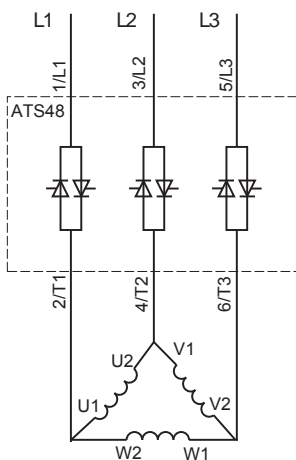

The motor connection depends on the supply voltage, which in this example is a delta connection.

See application diagram **page 114**

Operating recommendations

The Altistart 48 connected in the motor delta winding in series with each winding

ATS48●●●Q or ATS48●●●YS316 starters connected to motors with delta connections can be inserted in series in the motor windings. They are powered by a current which is less than the line current by a factor of $\sqrt{3}$, which enables a starter with a lower rating to be used.

Note: This option can be configured in the Advanced settings menu (dLt = On).

The nominal current and limiting current settings as well as the current displayed during operation are on-line values and so do not have to be calculated by the user.



The Altistart 48 can only be connected in the motor delta winding for ATS48●●●Q or ATS48●●●YS316 starters. This means that:

- dynamic braking stop is not possible
- cascading is not possible
- preheating is not possible

See the tables on page 96 for more information about starter-motor combinations.

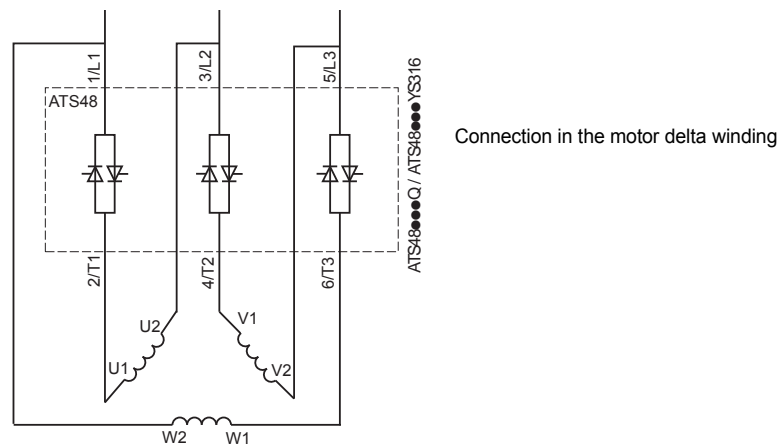

See application diagram **page 115**

Example:

A 400 V - 110 kW motor with a line current of 195 A (nominal current for the delta connection).

The current in each winding is equal to $195/1.7$ or 114 A.

The rating is determined by selecting the starter with a maximum permanent nominal current just above this current, i.e. 140 A (ATS48C14Q for a standard application).

To avoid having to calculate the rating in this way, use the tables on page 98 and 99 which indicate the rating of the starter corresponding to the motor power for each application type.



Standard application, 230/415 V supply, starter with line connection

Motor		Starter 230/415 V (+ 10% - 15%) - 50/60 Hz		
Nominal motor power		Max. permanent current in class 10	ICL rating	Starter reference
230 V	400 V			
kW	kW	A	A	
4	7.5	17	17	ATS 48D17Q
5.5	11	22	22	ATS 48D22Q
7.5	15	32	32	ATS 48D32Q
9	18.5	38	38	ATS 48D38Q
11	22	47	47	ATS 48D47Q
15	30	62	62	ATS 48D62Q
18.5	37	75	75	ATS 48D75Q
22	45	88	88	ATS 48D88Q
30	55	110	110	ATS 48C11Q
37	75	140	140	ATS 48C14Q
45	90	170	170	ATS 48C17Q
55	110	210	210	ATS 48C21Q
75	132	250	250	ATS 48C25Q
90	160	320	320	ATS 48C32Q
110	220	410	410	ATS 48C41Q
132	250	480	480	ATS 48C48Q
160	315	590	590	ATS 48C59Q
(1)	355	660	660	ATS 48C66Q
220	400	790	790	ATS 48C79Q
250	500	1000	1000	ATS 48M10Q
355	630	1200	1200	ATS 48M12Q

The nominal motor current I_n must not exceed the max. permanent current in class 10.

(1) Value not indicated when there is no corresponding standardised motor.

Temperature derating

The information in the table above is based on operation at a maximum ambient temperature of 40°C.

The ATS 48 can be used up to an ambient temperature of 60°C as long as the max. permanent current in class 10 is derated by 2% for each degree above 40°C.

Example: ATS 48D32Q at 50°C derated by $10 \times 2\% = 20\%$, 32 A becomes $32 \times 0.8 = 25.6$ A (max. nominal motor current).



Severe application, 230/415 V supply, starter with line connection

Motor		Starter 230/415 V (+ 10% - 15%) - 50/60 Hz		
Nominal motor power		Max. permanent current in class 20	ICL rating	Starter reference
230 V	400 V			
kW	kW	A	A	
3	5.5	12	17	ATS 48D17Q
4	7.5	17	22	ATS 48D22Q
5.5	11	22	32	ATS 48D32Q
7.5	15	32	38	ATS 48D38Q
9	18.5	38	47	ATS 48D47Q
11	22	47	62	ATS 48D62Q
15	30	62	75	ATS 48D75Q
18.5	37	75	88	ATS 48D88Q
22	45	88	110	ATS 48C11Q
30	55	110	140	ATS 48C14Q
37	75	140	170	ATS 48C17Q
45	90	170	210	ATS 48C21Q
55	110	210	250	ATS 48C25Q
75	132	250	320	ATS 48C32Q
90	160	320	410	ATS 48C41Q
110	220	410	480	ATS 48C48Q
132	250	480	590	ATS 48C59Q
160	315	590	660	ATS 48C66Q
(1)	355	660	790	ATS 48C79Q
220	400	790	1000	ATS 48M10Q
250	500	1000	1200	ATS 48M12Q

The nominal motor current I_n must not exceed the max. permanent current in class 20.

(1) Value not indicated when there is no corresponding standardised motor.

Temperature derating

The information in the table above is based on operation at a maximum ambient temperature of 40°C.

The ATS 48 can be used up to an ambient temperature of 60°C as long as the max. permanent current in class 20 is derated by 2% for each degree above 40°C.

Example: ATS 48D32Q at 50°C derated by $10 \times 2\% = 20\%$, 22 A becomes $22 \times 0.8 = 17.6$ A (max. nominal motor current).



Standard application, 230/415 V supply, starter with delta connection

Motor		Starter 230/415 V (+ 10% - 15%) - 50/60 Hz		
Nominal motor power		Max. permanent current in class 10	ICL rating	Starter reference
230 V	400 V			
kW	kW	A	A	
7.5	15	29	29	ATS 48D17Q
9	18.5	38	38	ATS 48D22Q
15	22	55	55	ATS 48D32Q
18.5	30	66	66	ATS 48D38Q
22	45	81	81	ATS 48D47Q
30	55	107	107	ATS 48D62Q
37	55	130	130	ATS 48D75Q
45	75	152	152	ATS 48D88Q
55	90	191	191	ATS 48C11Q
75	110	242	242	ATS 48C14Q
90	132	294	294	ATS 48C17Q
110	160	364	364	ATS 48C21Q
132	220	433	433	ATS 48C25Q
160	250	554	554	ATS 48C32Q
220	315	710	710	ATS 48C41Q
250	355	831	831	ATS 48C48Q
(1)	400	1022	1022	ATS 48C59Q
315	500	1143	1143	ATS 48C66Q
355	630	1368	1368	ATS 48C79Q
(1)	710	1732	1732	ATS 48M10Q
500	(1)	2078	2078	ATS 48M12Q

The nominal motor current I_n must not exceed the max. permanent current in class 10.

(1) Value not indicated when there is no corresponding standardised motor.

Temperature derating

The information in the table above is based on operation at a maximum ambient temperature of 40°C.

The ATS 48 can be used up to an ambient temperature of 60°C as long as the max. permanent current in class 10 is derated by 2% for each degree above 40°C.

Example: ATS 48D32Q at 50°C derated by $10 \times 2\% = 20\%$, 55 A becomes $55 \times 0.8 = 44$ A (max. nominal motor current).



Severe application, 230/415 V supply, starter with delta connection

Motor		Starter 230/415 V (+ 10% - 15%) - 50/60 Hz		
Nominal motor power		Max. permanent current in class 20	ICL rating	Starter reference
230 V	400 V			
kW	kW	A	A	
5.5	11	22	29	ATS 48D17Q
7.5	15	29	38	ATS 48D22Q
9	18.5	38	55	ATS 48D32Q
15	22	55	66	ATS 48D38Q
18.5	30	66	81	ATS 48D47Q
22	45	81	107	ATS 48D62Q
30	55	107	130	ATS 48D75Q
37	55	130	152	ATS 48D88Q
45	75	152	191	ATS 48C11Q
55	90	191	242	ATS 48C14Q
75	110	242	294	ATS 48C17Q
90	132	294	364	ATS 48C21Q
110	160	364	433	ATS 48C25Q
132	220	433	554	ATS 48C32Q
160	250	554	710	ATS 48C41Q
220	315	710	831	ATS 48C48Q
250	355	831	1022	ATS 48C59Q
(1)	400	1022	1143	ATS 48C66Q
315	500	1143	1368	ATS 48C79Q
355	630	1368	1732	ATS 48M10Q
(1)	710	1732	2078	ATS 48M12Q

The nominal motor current I_n must not exceed the max. permanent current in class 20.

(1) Value not indicated when there is no corresponding standardised motor.

Temperature derating

The information in the table above is based on operation at a maximum ambient temperature of 40°C.

The ATS 48 can be used up to an ambient temperature of 60°C as long as the max. permanent current in class 20 is derated by 2% for each degree above 40°C.

Example: ATS 48D32Q at 50°C derated by $10 \times 2\% = 20\%$, 38 A becomes $38 \times 0.8 = 30.4$ A (max. nominal motor current).



Standard application, 208/690 V supply, starter with line connection

Motor							Starter 208/690 V (+ 10% - 15%) - 50/60 Hz		
Nominal motor power							Max. permanent current in class 10	ICL rating	Starter reference
208 V	230 V	440 V	460 V	500 V	575 V	690 V			
HP	HP	kW	HP	kW	HP	kW	A	A	
3	5	7.5	10	9	15	15	17	17	ATS 48D17Y
5	7.5	11	15	11	20	18.5	22	22	ATS 48D22Y
7,5	10	15	20	18.5	25	22	32	32	ATS 48D32Y
10	(1)	18.5	25	22	30	30	38	38	ATS 48D38Y
(1)	15	22	30	30	40	37	47	47	ATS 48D47Y
15	20	30	40	37	50	45	62	62	ATS 48D62Y
20	25	37	50	45	60	55	75	75	ATS 48D75Y
25	30	45	60	55	75	75	88	88	ATS 48D88Y
30	40	55	75	75	100	90	110	110	ATS 48C11Y
40	50	75	100	90	125	110	140	140	ATS 48C14Y
50	60	90	125	110	150	160	170	170	ATS 48C17Y
60	75	110	150	132	200	200	210	210	ATS 48C21Y
75	100	132	200	160	250	250	250	250	ATS 48C25Y
100	125	160	250	220	300	315	320	320	ATS 48C32Y
125	150	220	300	250	350	400	410	410	ATS 48C41Y
150	(1)	250	350	315	400	500	480	480	ATS 48C48Y
(1)	200	355	400	400	500	560	590	590	ATS 48C59Y
200	250	400	500	(1)	600	630	660	660	ATS 48C66Y
250	300	500	600	500	800	710	790	790	ATS 48C79Y
350	350	630	800	630	1000	900	1000	1000	ATS 48M10Y
400	450	710	1000	800	1200	(1)	1200	1200	ATS 48M12Y

The nominal motor current I_n must not exceed the max. permanent current in class 10.

(1) Value not indicated when there is no corresponding standardised motor.

Temperature derating

The information in the table above is based on operation at a maximum ambient temperature of 40°C.

The ATS 48 can be used up to an ambient temperature of 60°C as long as the max. permanent current in class 10 is derated by 2% for each degree above 40°C.

Example: ATS 48D32Y at 50°C derated by $10 \times 2\% = 20\%$, 32 A becomes $32 \times 0.8 = 25.6$ A (max. nominal motor current).



Severe application, 208/690 V supply, starter with line connection

Motor								Starter 208/690 V (+ 10% - 15%) - 50/60 Hz		
Nominal motor power								Max. permanent current in class 20	ICL rating	Starter reference
208 V	230 V	440 V	460 V	500 V	575 V	690 V				
HP	HP	kW	HP	kW	HP	kW	A	A		
2	3	5.5	7.5	7.5	10	11	12	17	ATS 48D17Y	
3	5	7.5	10	9	15	15	17	22	ATS 48D22Y	
5	7.5	11	15	11	20	18.5	22	32	ATS 48D32Y	
7,5	10	15	20	18.5	25	22	32	38	ATS 48D38Y	
10	(1)	18.5	25	22	30	30	38	47	ATS 48D47Y	
(1)	15	22	30	30	40	37	47	62	ATS 48D62Y	
15	20	30	40	37	50	45	62	75	ATS 48D75Y	
20	25	37	50	45	60	55	75	88	ATS 48D88Y	
25	30	45	60	55	75	75	88	110	ATS 48C11Y	
30	40	55	75	75	100	90	110	140	ATS 48C14Y	
40	50	75	100	90	125	110	140	170	ATS 48C17Y	
50	60	90	125	110	150	160	170	210	ATS 48C21Y	
60	75	110	150	132	200	200	210	250	ATS 48C25Y	
75	100	132	200	160	250	250	250	320	ATS 48C32Y	
100	125	160	250	220	300	315	320	410	ATS 48C41Y	
125	150	220	300	250	350	400	410	480	ATS 48C48Y	
150	(1)	250	350	315	400	500	480	590	ATS 48C59Y	
(1)	200	355	400	400	500	560	590	660	ATS 48C66Y	
200	250	400	500	(1)	600	630	660	790	ATS 48C79Y	
250	300	500	600	500	800	710	790	1000	ATS 48M10Y	
350	350	630	800	630	1000	900	1000	1200	ATS 48M12Y	

The nominal motor current I_n must not exceed the max. permanent current in class 20.

(1) Value not indicated when there is no corresponding standardised motor.

Temperature derating

The information in the table above is based on operation at a maximum ambient temperature of 40°C.

The ATS 48 can be used up to an ambient temperature of 60°C as long as the max. permanent current in class 20 is derated by 2% for each degree above 40°C.

Example: ATS 48D32Y at 50°C derated by $10 \times 2\% = 20\%$, 22 A becomes $22 \times 0.8 = 17.6$ A (max. nominal motor current).

Dimensions

ATS 48D17 • ...C66 •

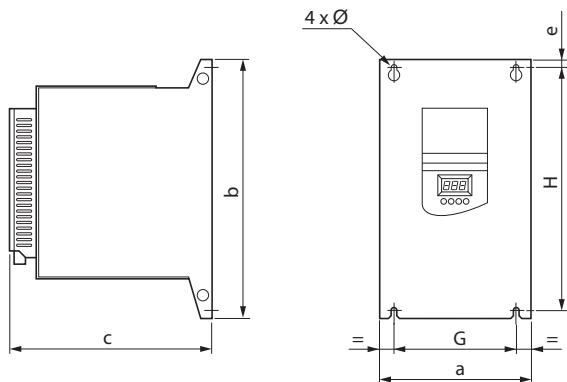

ATS 48	a mm	b mm	c mm	e mm	G mm	H mm	Ø mm	Weight kg
D17Q, D17Y D22Q, D22Y D32Q, D32Y D38Q, D38Y D47Q, D47Y	160	275	190	6.6	100	260	7	4.9
D62Q, D62Y D75Q, D75Y D88Q, D88Y C11Q, C11Y	190	290	235	10	150	270	7	8.3
C14Q, C14Y C17Q, C17Y	200	340	265	10	160	320	7	12.4
C21Q, C21Y C25Q, C25Y C32Q, C32Y	320	380	265	15	250	350	9	18.2
C41Q, C41Y C48Q, C48Y C59Q, C59Y C66Q, C66Y	400	670	300	20	300	610	9	51.4

Dimensions

ATS 48C79 • ...M12 •

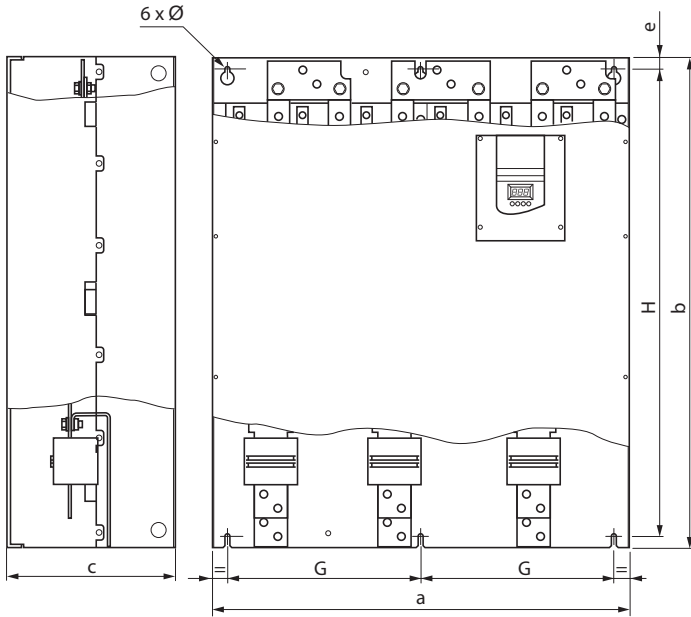

ENGLISH

ATS 48	a mm	b mm	c mm	e mm	G mm	H mm	Ø mm	Weight kg
C79Q, C79Y M10Q, M10Y M12Q, M12Y	770	890	315	20	350	850	11	115

Mounting recommendations

Install the unit vertically, at $\pm 10^\circ$.

Do not install the unit close to, especially above, heating elements.

Leave sufficient free space to ensure that the air required for cooling purposes can circulate from the bottom to the top of the unit.

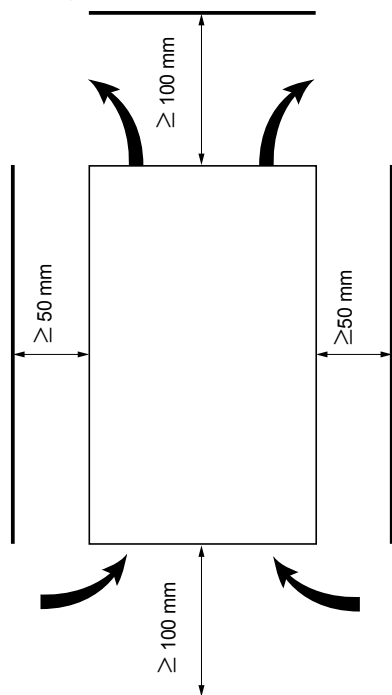

Check that no liquids, dust or conductive objects can fall into the starter (degree of protection IP00 from above)

Starter ventilation

On starters fitted with a cooling fan, the fan is switched on automatically as soon as the heatsink temperature reaches 50°C . It is switched off when the temperature falls back to 40°C .

Fan flow rate:

ATS 48 D32 • and D38 •	: 14 m ³ /hour
ATS 48 D47 •	: 28 m ³ /hour
ATS 48 D62 • to C11 •	: 86 m ³ /hour
ATS 48 C14 • and C17 •	: 138 m ³ /hour
ATS 48 C21 • to C32 •	: 280 m ³ /hour
ATS 48 C41 • to C66 •	: 600 m ³ /hour
ATS 48 C79 • to M12 •	: 1,200 m ³ /hour

Mounting in a wall-fixing or floor-standing enclosure

Metal wall-fixing or floor-standing enclosure with IP 23 degree of protection

Observe the mounting recommendations on the previous page.

To ensure proper air circulation in the drive:

- Fit ventilation grilles.
- Ensure that ventilation is adequate: if not install a forced ventilation unit, with a filter if necessary.

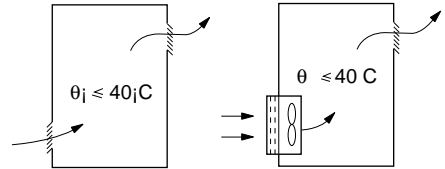

Power dissipated by the starters, not bypassed, at their nominal current

Starter reference ATS 48	Power in W	Starter reference ATS 48	Power in W
D17Q, D17Y	59	C21Q, C21Y	580
D22Q, D22Y	74	C25Q, C25Y	695
D32Q, D32Y	104	C32Q, C32Y	902
D38Q, D38Y	116	C41Q, C41Y	1339
D47Q, D47Y	142	C48Q, C48Y	1386
D62Q, D62Y	201	C59Q, C59Y	1731
D75Q, D75Y	245	C66Q, C66Y	1958
D88Q, D88Y	290	C79Q, C79Y	2537
C11Q, C11Y	322	M10Q, M10Y	2865
C14Q, C14Y	391	M12Q, M12Y	3497
C17Q, C17Y	479		

Note: When the starters are bypassed the amount of power dissipated is extremely small (between 15 and 30 W)

- Control consumption (all ratings): 25 W non-ventilated
- Control consumption with fan ventilated :

Soft start	Power consumption (W)	Apparent power (VA)
ATS 48D17● to C17●	30	80
ATS 48C21● to C32●	50	130
ATS 48C41● to M12●	80	240

Power terminals

Terminals	Functions	Maximum connection capacity Terminal tightening torque					
		ATS 48 D17 • D22 • D32 • D38 • D47 •	ATS 48 D62 • D75 • D88 • C11 •	ATS 48 C14 • C17 •	ATS 48 C21 • C25 • C32 •	ATS 48 C41 • C48 • C59 • C66 •	ATS 48 C79 • M10 • M12 •
⏚	Earth connections connected to earth	10 mm ² 1.7 N.m	16 mm ² 3 N.m	120 mm ² 27 N.m	120 mm ² 27 N.m	240 mm ² 27 N.m	2x240 mm ² 27 N.m
		8 AWG 15 lb.in	4 AWG 26 lb.in	Busbar 238 lb.in	Busbar 238 lb.in	Busbar 238 lb.in	Busbar 238 lb.in
1/L1 3/L2 5/L3	Power supply	16 mm ² 3 N.m	50 mm ² 10 N.m	95 mm ² 34 N.m	240 mm ² 34 N.m	2x240 mm ² 57 N.m	4x240 mm ² 57 N.m
		8 AWG 26 lb.in	2/0 AWG 88 lb.in	2/0 AWG 300 lb.in	Busbar 300 lb.in	Busbar 500 lb.in	Busbar 500 lb.in
2/T1 4/T2 6/T3	Outputs to motor	16 mm ² 3 N.m	50 mm ² 10 N.m	95 mm ² 34 N.m	240 mm ² 34 N.m	2x240 mm ² 57 N.m	4x240 mm ² 57 N.m
		8 AWG 26 lb.in	2/0 AWG 88 lb.in	2/0 AWG 300 lb.in	Busbar 300 lb.in	Busbar 500 lb.in	Busbar 500 lb.in
A2 B2 C2	Starter bypass	16 mm ² 3 N.m	50 mm ² 10 N.m	95 mm ² 34 N.m	240 mm ² 34 N.m	2x240 mm ² 57 N.m	4x240 mm ² 57 N.m
		8 AWG 26 lb.in	2/0 AWG 88 lb.in	2/0 AWG 300 lb.in	Busbar 300 lb.in	Busbar 500 lb.in	Busbar 500 lb.in

Layout of the power terminals, ATS 48D17 • to C11 •

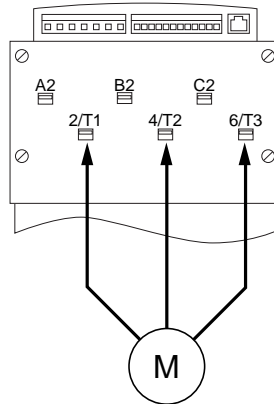
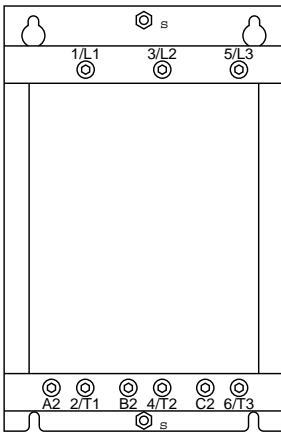

Motor to be connected to 2/T1, 4/T2, 6/T3

Power terminals

Layout of the power terminals, ATS 48C14 • and C17 •

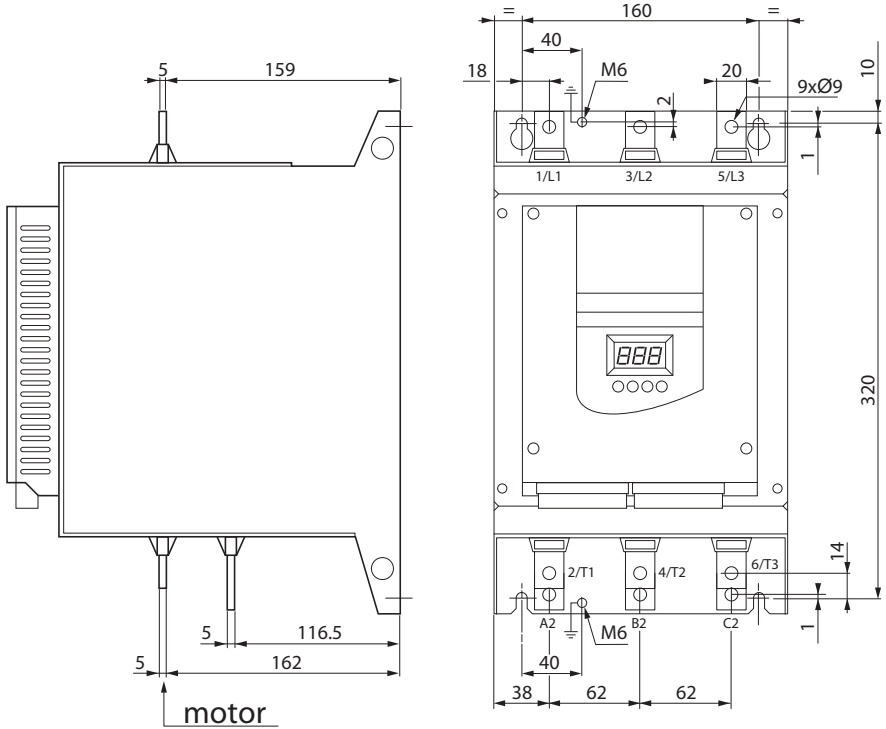

Power terminals

Layout of the power terminals, ATS 48C41 • to C66 •

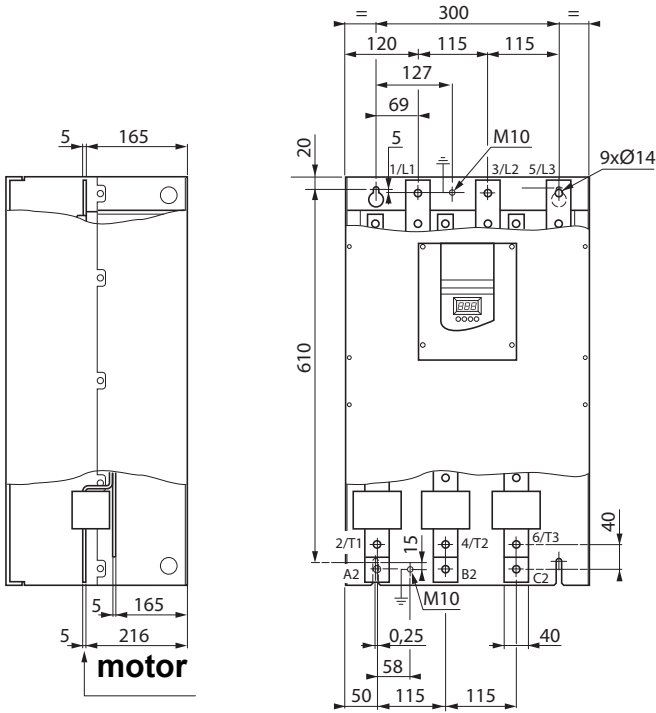

Power terminals

Layout of the power terminals, ATS 48C79 • to M12 •

ENGLISH

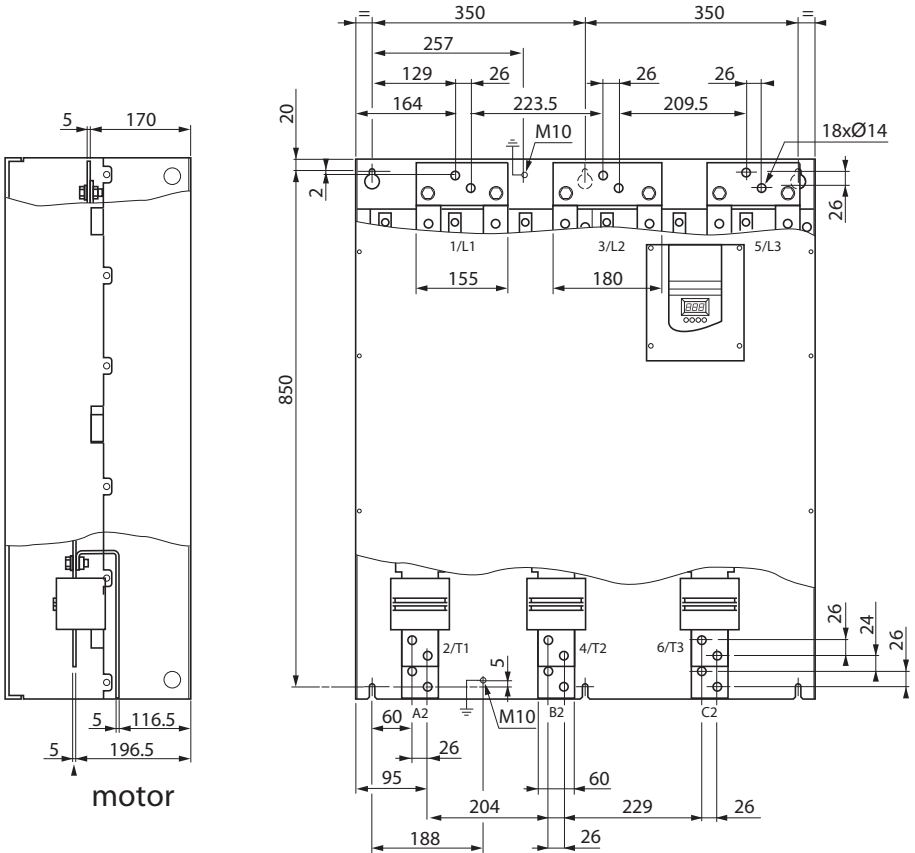

Control terminals

The control terminals are fitted with one way plug-in connectors.

Maximum connection capacity : 2.5 mm² (12 AWG)
 Maximum tightening torque : 0.4 N.m (3.5 lb.in)

In order to access the control terminals on ATS 48C17 • to M12 • starters, the protective cover must be removed.

Electrical characteristics

Terminals	Function	Characteristics
CL1 CL2	Altistart control power supply	ATS 48 ●●● Q: 220 to 415 V + 10% - 15%, 50/60 Hz ATS 48 ●●● Y: 110 to 230 V + 10% - 15%, 50/60 Hz Consumption see page 105.
R1A R1C	Normally open (N/O) contact of programmable relay r1	Min. switching capacity • 10 mA for 6 V --- Max. switching capacity on inductive load (cos φ = 0.5 and L/R = 20 ms): • 1.8 A for 230 V~ and 30 V --- Max. voltage 400 V
R2A R2C	Normally open (N/O) contact of end of starting relay r2	
R3A R3C	Normally open (N/O) contact of programmable relay r3	
STOP RUN LI3 LI4	Stop starter (state 0 = stop) Run starter (state 1 = run if STOP is at 1) Programmable input Programmable input	4 x 24 V logic inputs with 4.3 kW impedance U _{max} = 30 V, I _{max} = 8 mA state 1: U > 11 V - I > 5 mA state 0: U < 5 V - I < 2 mA
24V	Logic input power supply	+24 V ± 25% isolated and protected against short-circuits and overloads, maximum current: 200 mA
LO+	Logic output power supply	To be connected to 24 V or an external source
LO1 LO2	Programmable logic outputs	2 open collector outputs, compatible with level 1 PLC, IEC 65A-68 standard. • Power supply +24 V (min. 12 V, max. 30 V) • Max. current 200 mA per output with an external source
AO1	Programmable analog output	Output can be configured as 0 - 20 mA or 4 - 20 mA • accuracy ± 5% of the max. value, max. load impedance 500 Ω
COM	I/O common	0 V
PTC1 PTC2	Input for PTC probes	Total resistance of probe circuit 750 W at 25°C (3 x 250 W probes in series, for example)
(RJ 45)	Connector for • remote terminal • PowerSuite • communication bus	RS 485 Modbus

Layout of control terminals

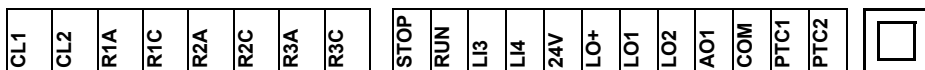

(RJ 45)

Wiring recommendations

Power

Observe the cable cross-sectional areas recommended in the standards.

The starter must be earthed to conform to the regulations concerning leakage currents. When the use of an upstream "residual current device" for protection is required by the installation standards, an A-Si type device must be used (to avoid accidental tripping during power up). Check its compatibility with the other protective devices. If the installation involves several starters on the same line, each starter must be earthed separately. If necessary, fit a line choke (consult the catalogue).

Keep the power cables separate from circuits in the installation with low-level signals (detectors, PLCs, measuring apparatus, video, telephone).

Control

Keep the control circuits away from the power cables.

Functions of the RUN and STOP logic inputs (See application diagram see page 114)

2-wire control

Run and stop are controlled by state 1 (run) or 0 (stop), which is taken into account at the same time on the RUN and STOP inputs.

On power-up or a manual fault reset the motor will restart if the RUN command is present.

3-wire control

Run and stop are controlled by 2 different logic inputs.
A stop is obtained on opening (state 0) the STOP input.
The pulse on the RUN input is stored until the stop input opens.

On power-up or a manual fault reset or after a stop command, the motor can only be powered once the RUN input has been opened (state 0) followed by a new pulse (state 1).

Application diagram



ATS 48: Non-reversing, with line contactor, freewheel stop, type 1 coordination

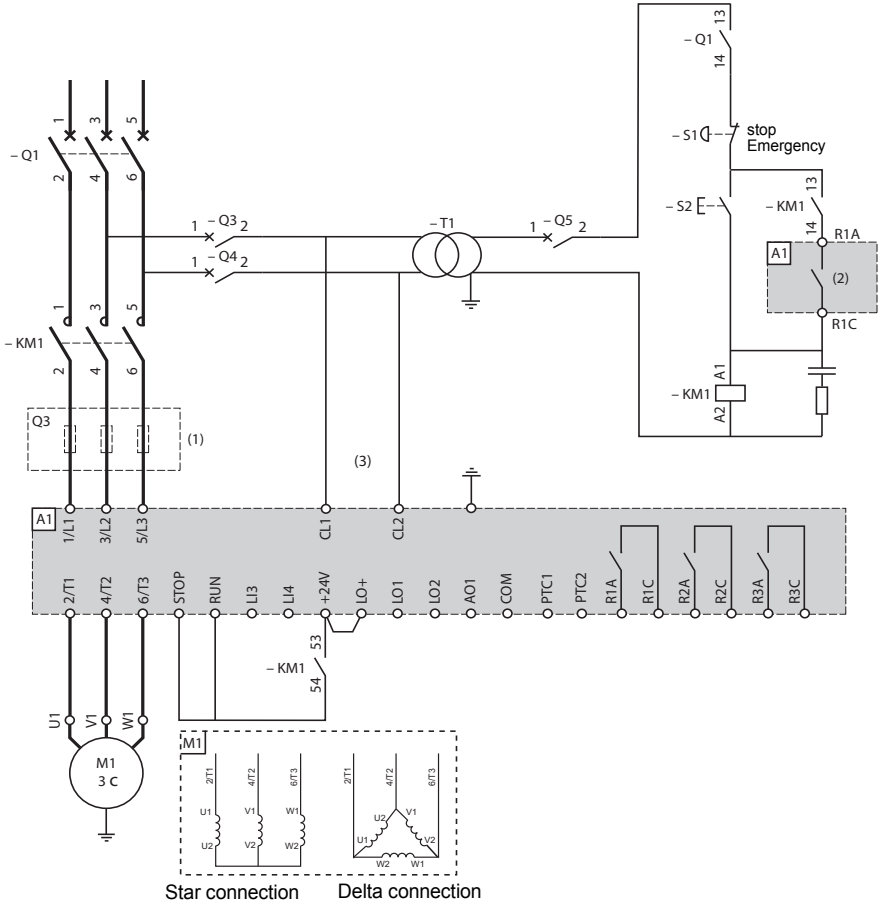

ENGLISH



- (1) Installation of fast-acting fuses for type 2 coordination (conforming to IEC 60 947-4-2)
- (2) Assignment of relay R1: isolating relay (r1l). See "Electrical characteristics", page 111. Beware of the operating limits of the contact, for example when connecting to high rating contactors.
- (3) Insert a transformer if the supply voltage is different to that permitted by the ATS 48 control. See "Electrical characteristics", page 111.

Application diagram



ATS 48: Non-reversing with line contactor, bypass, freewheel or controlled stop, type 1 coordination

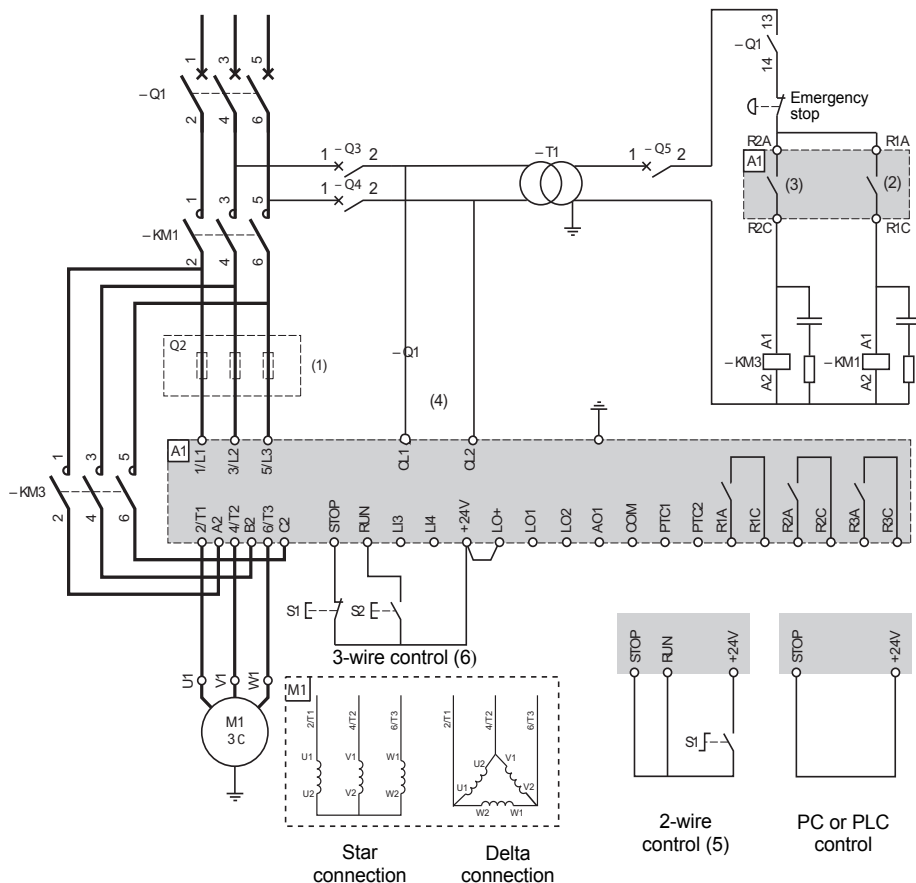

- (1) Installation of fast-acting fuses for type 2 coordination (conforming to IEC 60 947-4-2)
- (2) Assignment of relay R1: isolating relay (r11). Beware of the operating limits of the contact, for example when connecting to high rating contactors. See "Electrical characteristics", page 111.
- (3) Beware of the operating limits of the contact, for example when connecting to high rating contactors. See "Electrical characteristics", page 111.
- (4) Insert a transformer if the supply voltage is different to that permitted by the ATS 48 control. See "Electrical characteristics", page 111.
- (5) See "2-wire control", page 112.
- (6) See "3-wire control", page 112.

Application diagram



ATS 48: Non-reversing, freewheel stop, type 1 coordination, with line contactor, bypass, connection to delta in the motor, ATS 48...Q or ATS 48...YS316

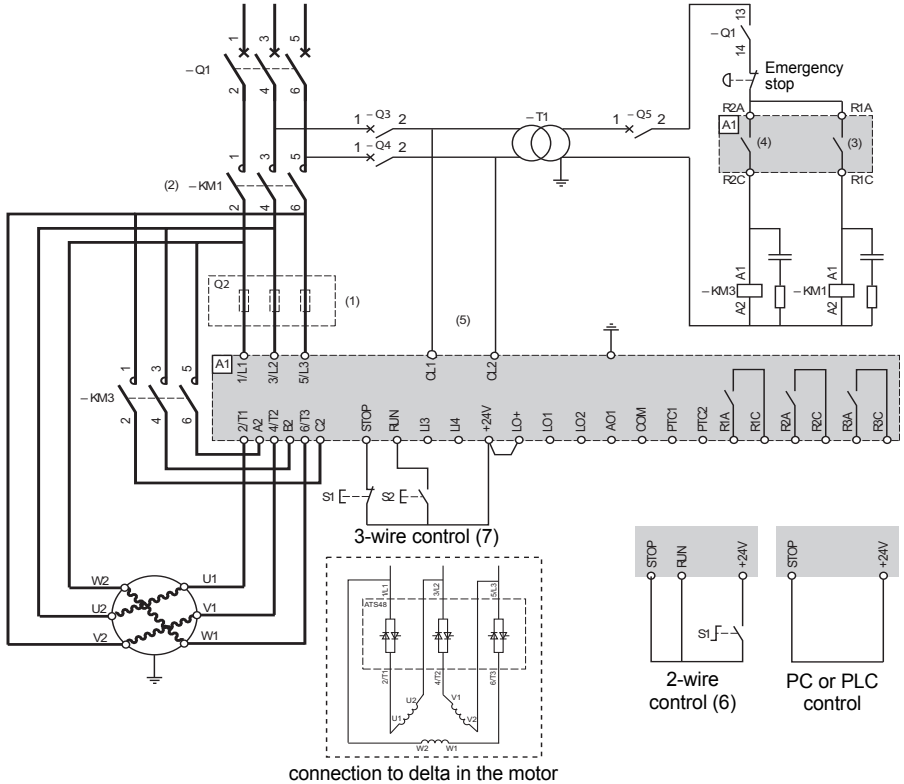

ENGLISH

Note: Set *dlk* to *on* (see "Advanced settings menu (drC)", page 141)



- (1) Installation of fast-acting fuses for type 2 coordination (conforming to IEC 60 947-4-2).
- (2) It is mandatory to use KM1. External differential thermal protection will need to be added type Vigirex pour Compact NS80, bloc Vigi pour Compact NS400 à 630, consulter le catalogue Merlin Gérin pour les calibres supérieurs.
- (3) Assignment of relay R1: isolating relay (r1l). Beware of the operating limits of the contact, for example when connecting to high rating contactors. See "Electrical characteristics", page 111.
- (4) Beware of the operating limits of the contact, for example when connecting to high rating contactors. See "Electrical characteristics", page 111.
- (5) Insert a transformer if the supply voltage is different to that permissible by the ATS 48 control. See "Electrical characteristics", page 111.
- (6) See "2-wire control", page 112.
- (7) See "3-wire control", page 112.
- (8) Inductances de lignes éventuelles



If the bypass contactor is used, "PHF" fault detection can be extended.

Application diagram



ATS 48: Non-reversing, freewheel or controlled stop, line contactor, motor bypass, LSP/HSP with two sets of parameters

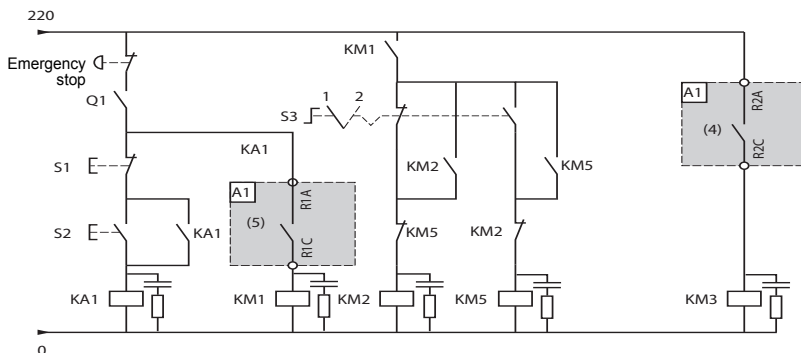
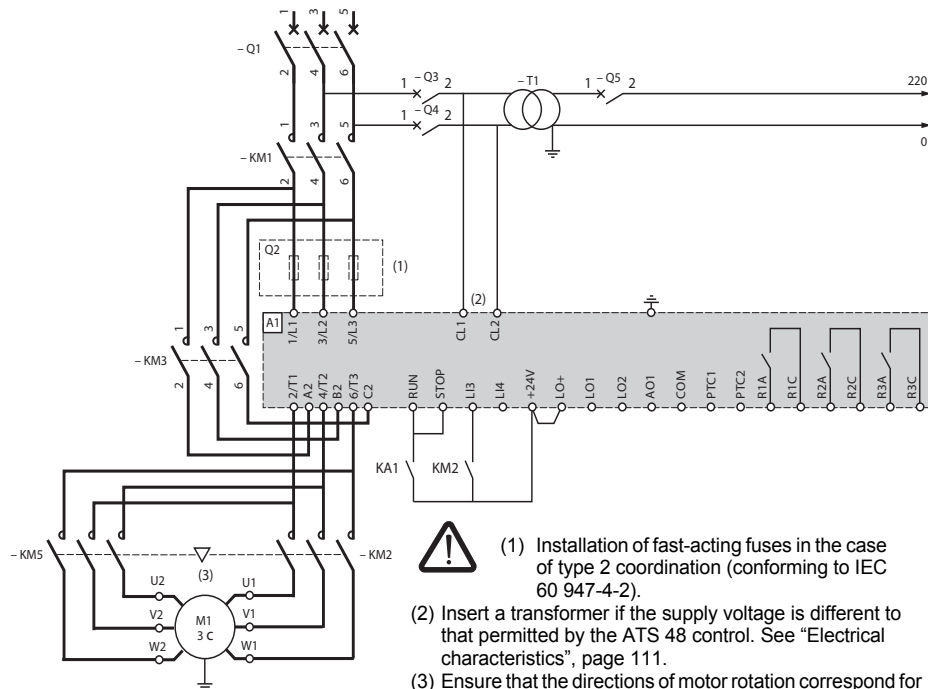



ATS 48: Non-reversing with line contactor, starting and deceleration of several cascaded motors with a single Altistart

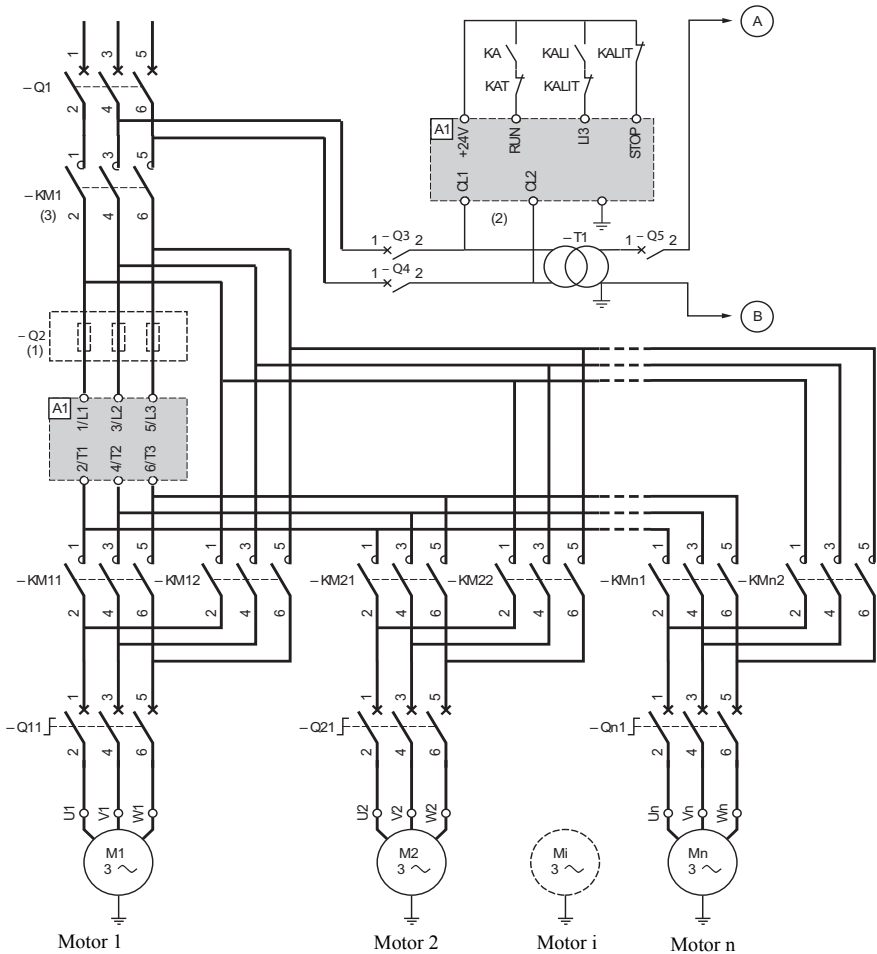

- (1) Installation of fuses for type 2 coordination (conforming to IEC 60 947-4-2)
- (2) Insert a transformer if the supply voltage is different to that permitted by the ATS 48 control. See "Electrical characteristics", page 111.
- (3) KM1: Must be sized in accordance with the total power of the motors.

Important:

- A "cascading" logic input must be configured on the ATS48 (LI3 = LIC). See "Activation of the cascade function", page 142.
- In the event of a fault it will not be possible to decelerate or brake any motors that may be running at that time.
- Adjust the thermal protection of each circuit breaker Qn1 to the nominal motor current.

Application diagram

ATS 48: Non-reversing with line contactor, starting and deceleration of several cascaded motors with a single Altistart

Motor 1 control

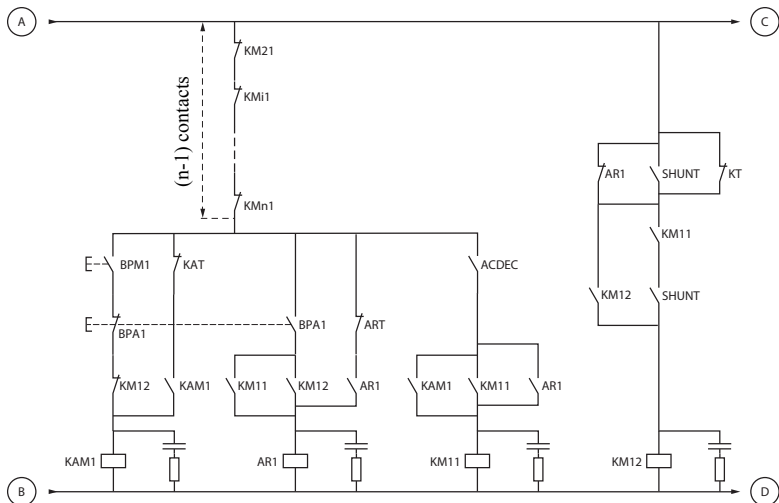

Motor 2 control

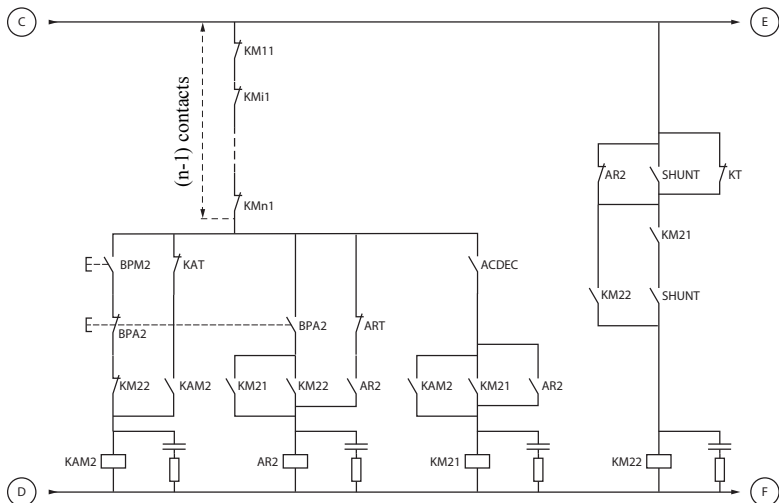

BPM1: "Run" button motor 1
BPM2: "Run" button motor 2

BPA1: "Stop" button motor 1
BPA2: "Stop" button motor 2

Application diagram

ATS 48: Non-reversing with line contactor, starting and deceleration of several cascaded motors with a single Altistart

Motor n control

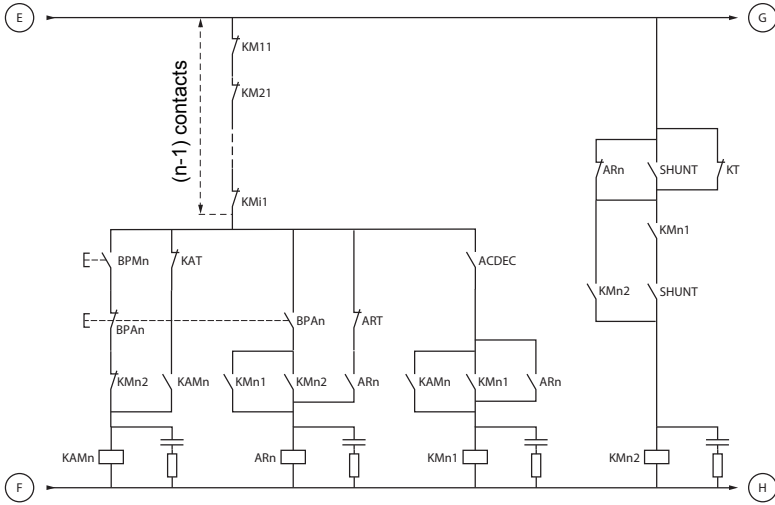

Cascade control

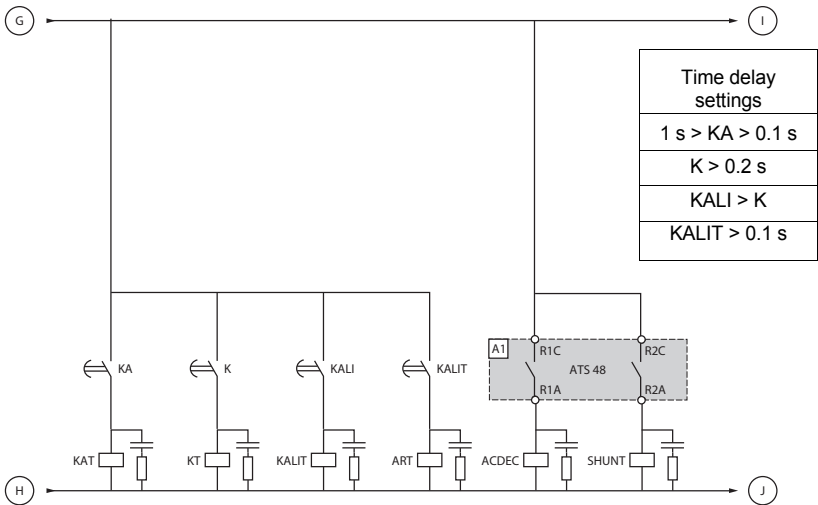

BPMn: "Run" button motor n
BPAn: "Stop" button motor n

R1 must be configured as an isolating relay ($r1 = r11$)



Wait for the end of the timer KALIT between 2 consecutive stop requests

Application diagram

ATS 48: Non-reversing with line contactor, starting and deceleration of several cascaded motors with a single Altistart

Cascade control

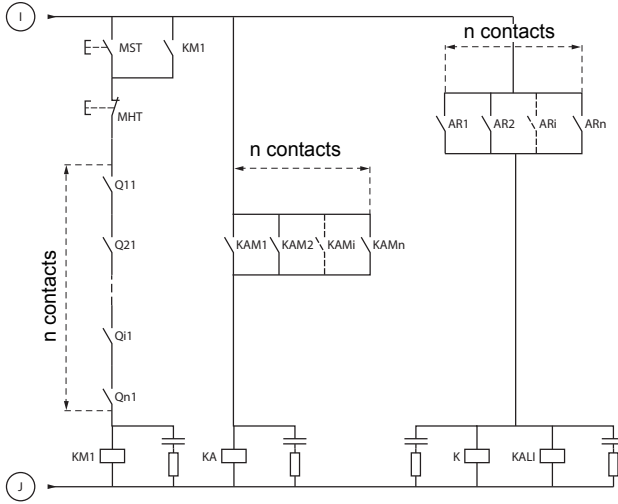

MST: General "Run" button
MHT: General "Stop" button

ATS 48: Non-reversing with line contactor, starting and deceleration of several cascaded motors with a single Altistart

Description of the complete sequence

Start with MST so that KM1 rises (line contactor)

1 - 2 - 3

Press BPM1 to start motor 1. Press BPM2 to start motor 2, press BPMn to start motor n.

When BPM1 is pressed, KAM1 rises, as does KM11 because ACDEC is activated (the ATS48 is powered by MST and KM1).

KA rises because KAM1 is closed. KAT also rises after an adjustable time delay.

4 - 5

The ATS48 starts the motor following a run command on RUN with KA and KAT.

KAM1 drops out due to KAT.

KM11 remains closed.

6 - 7

At the end of starting, R2 on the ATS48 rises, SHUNT is closed, KM12 is closed by SHUNT and KM11 remains closed.

8 - 9

After a short time R2 drops out followed by R1 (starter bypass function).

KM11 opens because ACDEC is open.

The motor continues to be powered by KM12.

ATS48 display a status code.

Follow the same procedure to start the next motor. To start motor n use BPMn and to stop motor n use BPA_n. The motors can be started and stopped in any order.

To stop motor 1 press BPA1. AR1 closes

a - b - c - d

K and KAL1 are closed.

LI on the ATS48 receives a command from KALI and KALIT (LI must be adjusted to value LIC).

R1 and R2 on the ATS48 rise (a pulse on R2 and R1 remains closed until the motor has come to a complete stop).

e

KM11 closes.

After an adjustable time delay, KT and KALIT rise.

f

The ATS48 receives a stop command from KALIT.

g

KM12 drops out.

The ATS48 decelerates the motor.

h

R1 on the ATS48 opens when the motor has come to a complete stop.

i

KM11 opens.

The ATS48 is ready to start or stop another motor.

Application diagram

ATS 48: Non-reversing with line contactor, starting and deceleration of several cascaded motors with a single Altistart

Trend diagram

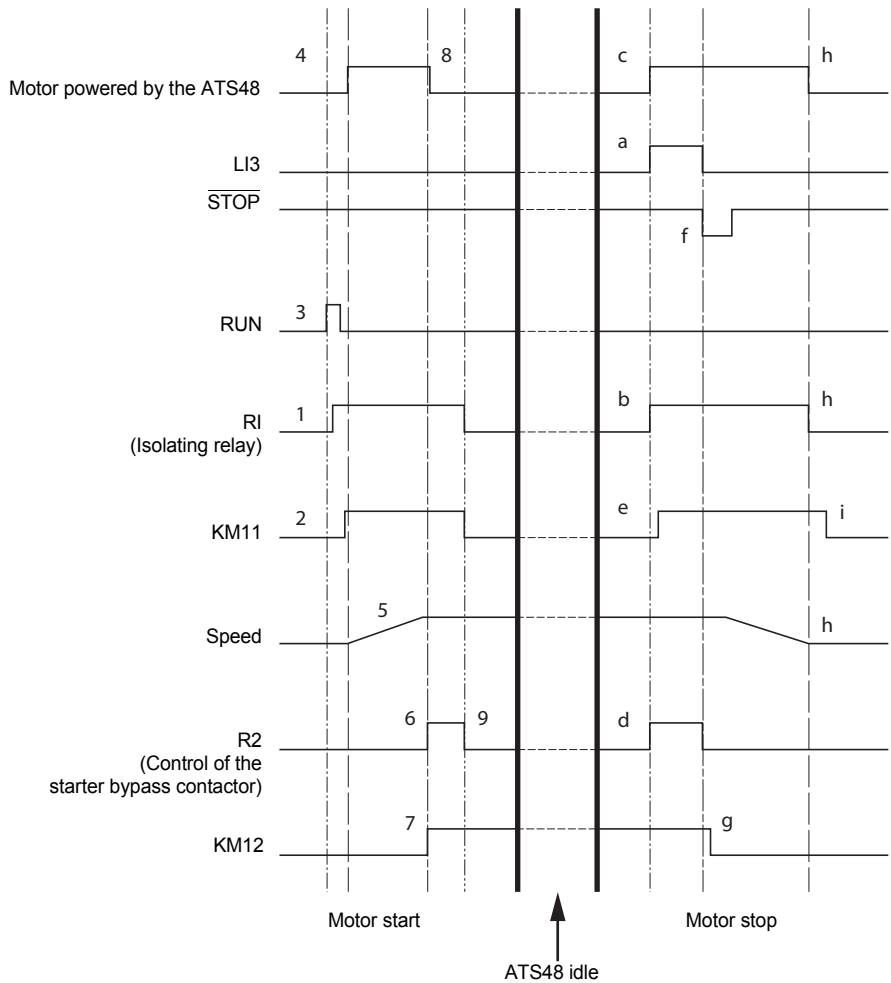

Starter thermal protection

Thermal protection is provided by the PTC probe fitted on the heatsink and by calculating the temperature rise of the thyristors.

Motor thermal protection

The starter continuously calculates the temperature rise of the motor based on the controlled nominal current I_n and the actual current absorbed.

Temperature rises can be caused by a low or high overload with a long or short duration. The tripping curves on the following pages are based on the relationship between the starting current I_s and the (adjustable) motor current I_n .

Standard IEC60947-4-2 defines the protection classes giving the starting capacities of the motor (warm or cold start) without thermal faults. Different protection classes are given for a COLD state (corresponding to a stabilised motor thermal state, switched off) and for a WARM state (corresponding to a stabilised motor thermal state, at nominal power).

The starter is factory-set to protection class 10.
This protection class can be modified using the PrO menu.

The thermal protection displayed by the starter corresponds to the iron time constant.

- An overload alarm is activated if the motor exceeds its nominal temperature rise threshold (motor thermal state = 110%).
- A thermal fault stops the motor if it exceeds the critical temperature rise threshold (motor thermal state = 125%).

In the event of a prolonged start, the starter can trip on a fault or thermal alarm even if the value displayed is less than the trip value.

The thermal fault can be indicated by relay R1 if thermal protection has not been disabled.

After the motor has stopped or the starter has been switched off, the thermal state is calculated even if the control circuit is not powered. The Altistart thermal control prevents the motor from restarting if the temperature rise is too high.

If a special motor is used (flameproof, submersible, etc.) thermal protection should be provided by PTC probes.

Thermal protection

Motor thermal protection

Cold curves

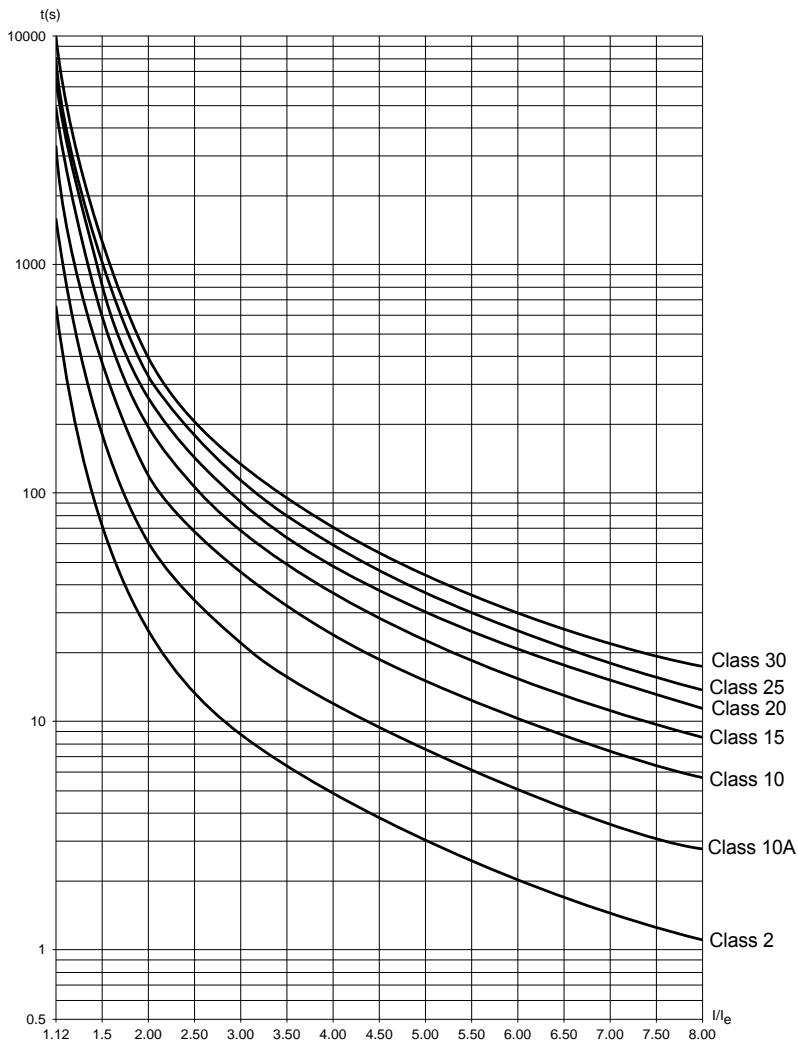

Trip time for a standard application (class 10)		Trip time for a severe application (class 20)	
3 In	5 In	3.5 In	5 In
46 s	15 s	63 s	29 s

Motor thermal protection

Warm curves

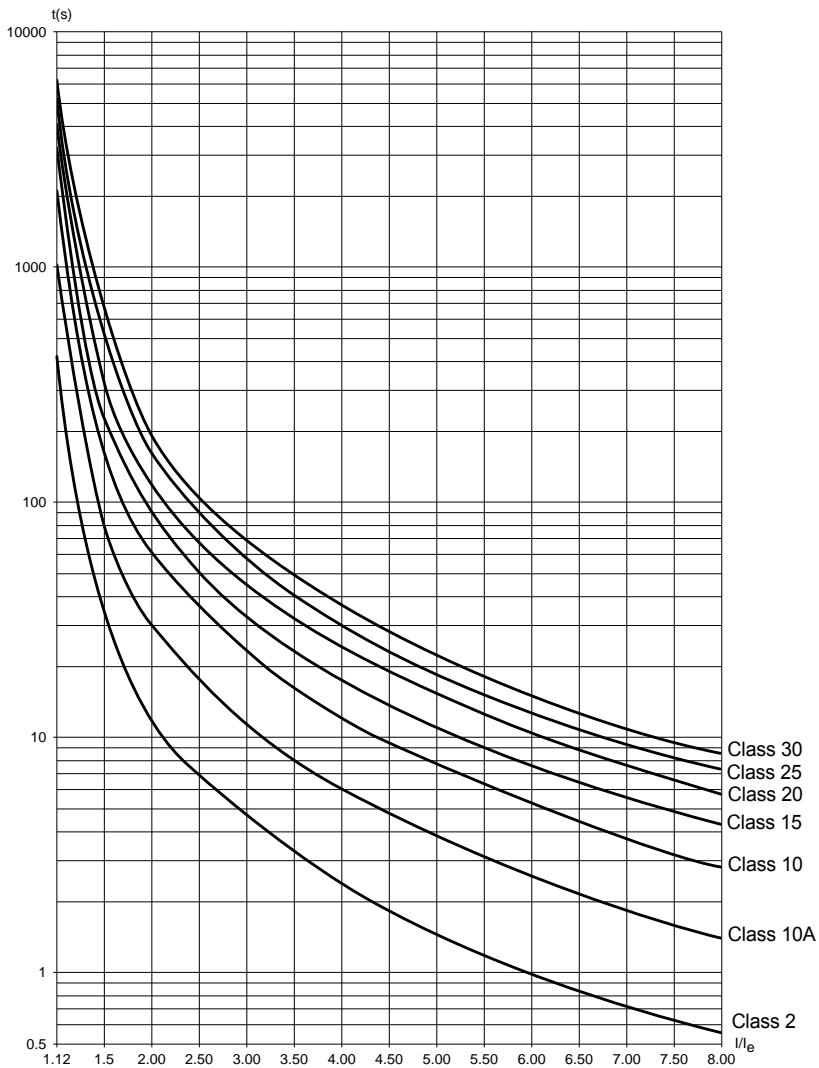

Trip time for a standard application (class 10)		Trip time for a severe application (class 20)	
3 In	5 In	3.5 In	5 In
23 s	7.5 s	32 s	15 s

Motor thermal protection with PTC probes

PTC probes integrated in the motor to measure its temperature can be connected to the control card terminals. This analog value is managed by the starter.

The "PTC probe thermal overshoot" value can be processed and used in two ways:

- stop in the event of a fault if the signal is active
- activate an alarm if the signal is active. This alarm can be displayed in a starter status word (serial link) or on a configurable logic output.



Note:

PTC probe protection does not deactivate the motor thermal protection provided by the calculation. Both types of protection can operate in parallel.

Display unit and programming

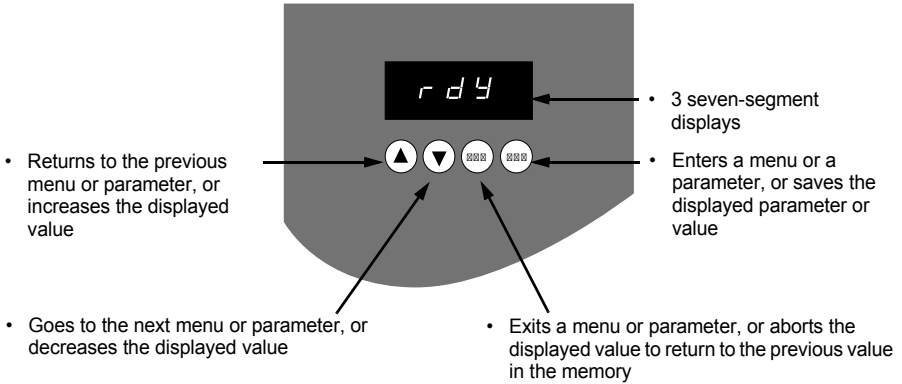
Functions of the keys and the display



Pressing  or  does not store the choices.

Store, save the displayed choice: 

The display flashes when a value is stored.

Display principle

The display principle for numbers differs depending on the maximum scale of the parameter and its value.

- Max. scale 9990:
 - values 0.1 to 99.9 (examples: 05.5 = 5.5; 55.0 = 55; 55.5 = 55.5)
 - values 100 to 999 (example: 555 = 555)
 - values 1000 to 9990 (example: 5.55 = 5550)
- Max. scale 99900:
 - values 1 to 999 (examples: 005 = 5; 055 = 55; 550 = 550)
 - values 1000 to 9990 (example: 5.55 = 5550)
 - values 10000 to 99900 (example: 55.5 = 55500)

Display unit and programming

Accessing menus

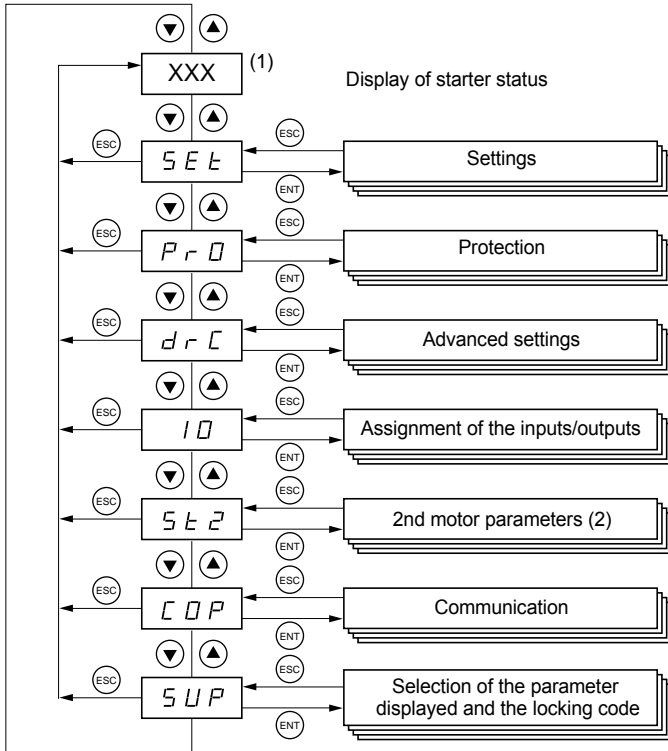

- (1) Management of the displayed value "XXX" is given in the table on the next page.
 (2) Menu St2. is only visible if the "second set of motor parameters" function is configured.

Accessing parameters

Store, save the displayed choice: (ENT)

The display flashes when a value is stored.

Example:

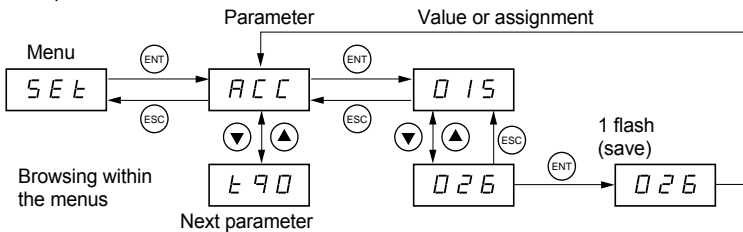

Display unit and programming

Display of starter status

The displayed value "XXX" follows the following rules:

Value displayed	Condition
Fault code	Faulty starter
nLP rdY	Starter without run command and: <ul style="list-style-type: none">• Power not supplied• Power supplied
tbS	Starting time delay not elapsed
HEA	Motor heating in progress
Monitoring parameter selected by the user (SUP menu). Factory setting: motor current	Starter with run command
brL	Starter braking
Stb	Waiting for a command (RUN or STOP) in cascade mode

When current limiting is applied to the starter, the displayed value "XXX" flashes.

It is still possible to modify the parameters even if a fault occurs on the starter.

Remote terminal option

The **VW3 G48101** remote terminal can be mounted on the door of the wall-mounted or floor-standing enclosure with a seal which offers IP 65 protection. It has a 3 m cable with connectors and communication is via the RJ45/Modbus connection on the starter (**see the manual supplied with the terminal**). It has the same display and the same programming buttons as the Altistart 48 with the addition of a menu access locking switch.

View of the front panel:

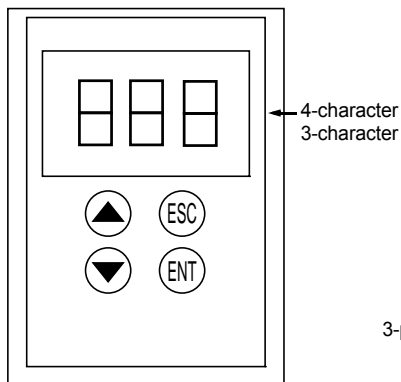

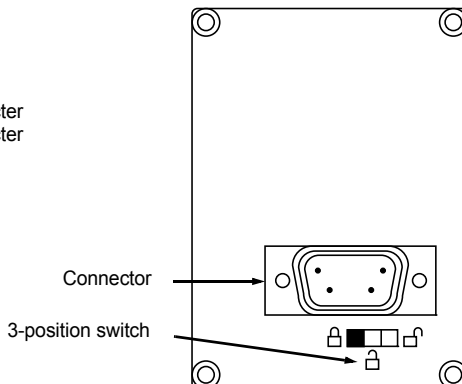

View of the rear panel:



Control of the remote terminal switch

The 3-position switch on the terminal is used as follows:

- locked position  : only the monitoring parameters can be accessed. When the starter is running, it is not possible to select a different parameter to be displayed.
- partly locked position  : limited access to the SEt, PrO and SUP menu parameters.
- unlocked position  : all parameters can be accessed.

Any display restrictions applied to the starter by the remote terminal switch will still be in force once the starter has been disconnected and even after it has been switched off.

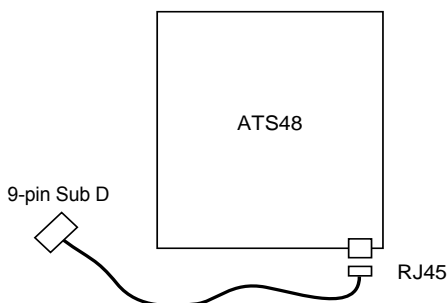

Settings menu (Set)

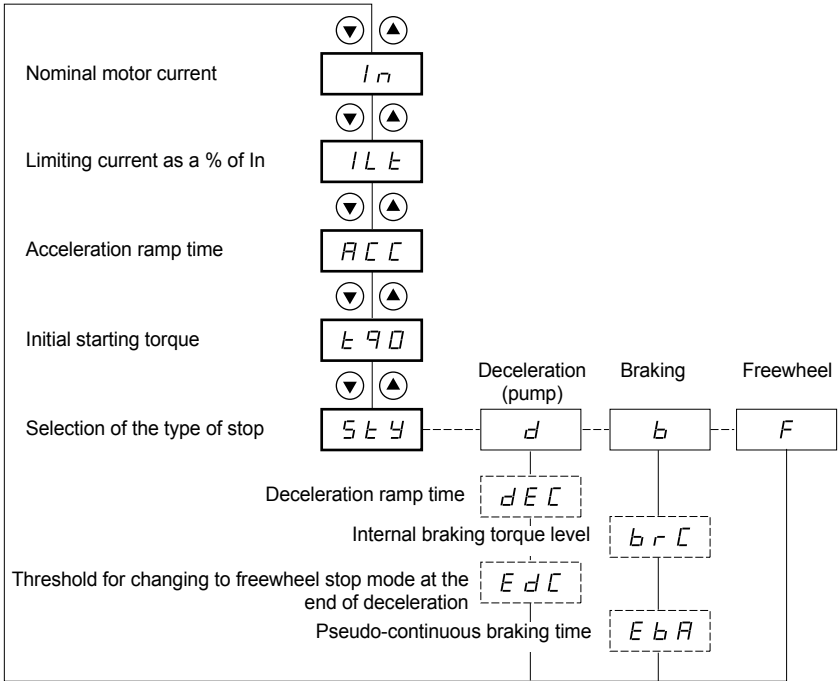

- Parameters in menu
- Can be selected
- Parameter appears according to selection

To access the parameters, see page 128.

Settings menu (Set)

The settings parameters can only be modified when the motor is stopped.

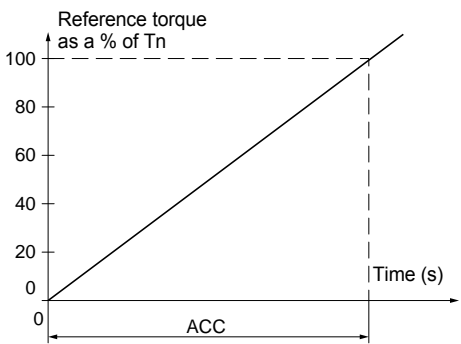
Code	Description	Setting range	Factory setting
I_n	Nominal motor current Adjust the value of the nominal motor current indicated on the rating plate, even if the starter is connected in the motor delta winding (dLt in the PrO menu). Check that the current is between 0.4 and 1.3 ICL (ICL: starter rating).	0.4 to 1.3 ICL	(1)
ILt	Limiting current The limiting current ILt is expressed as a % of In. With the maximum load, the ILt should be set at a high enough value to allow the motor to start. If the application requires more than 500% Icl, the starter must be oversized. It is limited to 500% of ICL (starter rating, see "Starter-motor combinations", page 96.) Limiting current = ILt x In. Example 1: In = 22 A, ILt = 300%, limiting current = 300% x 22 A = 66 A Example 2: ATS 48C21Q, with ICL = 210 A In = 195 A, ILt = 700%, limiting current = 700% x 195 = 1365, limited to 500% x 210 = 1050 A	150 to 700% of In, limited to 500% of ICL	400% of In
RCC	Acceleration ramp time This is the rise time of the starter torque between 0 and the nominal torque Tn, i.e. the gradient of the torque ramp on acceleration. 	1 to 60 s	15 s

- (1) Factory setting of In corresponding to the usual value of a 4-pole 400 V standardised motor with class 10 protection (for ATS 48***Q).
Factory setting of In corresponding to the usual value of a 460 V standardised motor in accordance with NEC and with class 10 protection (for ATS 48***Y).

Settings menu (Set)

Code	Description	Setting range	Factory setting
4 9 0	Initial starting torque Initial torque setting during the starting phases, varies from 0 to 100% of the nominal torque. Initial starting torque should be set in order to produce motor rotation as soon as the order is applied to the motor. If set too low, the motor will rotate later after the "Run" signal.	0 to 100% of T _n	20%
5 4 4	Selection of the type of stop Three types of stop are possible: - d -: Soft stopping by control of torque. The starter applies a motor torque in order to decelerate progressively on the ramp, avoiding a rapid stop. This type of stop reduces the risk of water hammer on a pump. - b -: Dynamic braking stop: The starter generates a braking torque in the motor which will slow the motor down if there is considerable inertia. - F -: Freewheel stop: No torque is applied to the motor by the starter. Note : If the starter is connected to "delta in the motor", stop type b is not permitted.	d-b-F	-F-

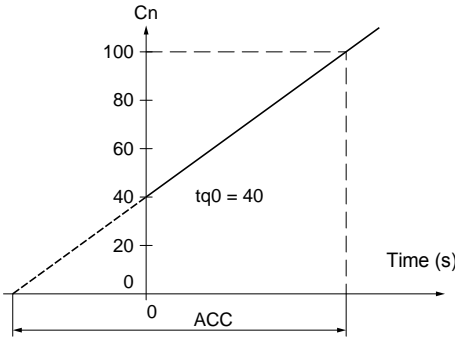

Settings menu (Set)

ENGLISH

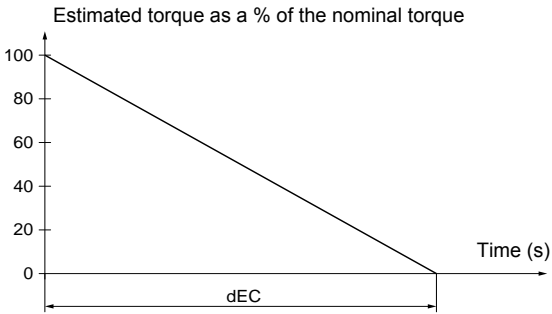
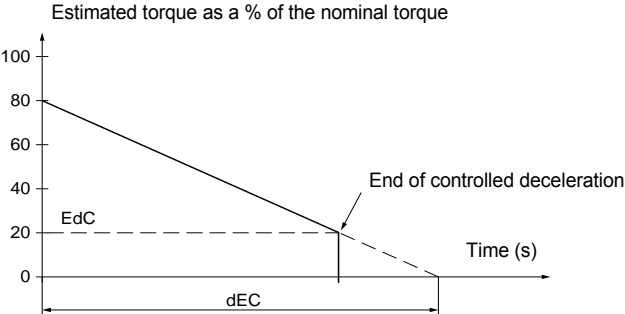
Code	Description	Setting range	Factory setting
dEC	<p>Deceleration ramp time</p> <p>This parameter can only be accessed if StY = -d-. Can be used to set a time between 1 to 60 s to switch from the estimated torque to zero torque (= gradient of the torque ramp on deceleration when a -d- stop is applied). This modifies the progression of the deceleration and avoids hydraulic shocks in pump applications by modifying the gradient of the torque reference.</p>  <p style="text-align: center;">Estimated torque as a % of the nominal torque</p>	1 to 60 s	15 s
EdC	<p>Threshold for changing to freewheel stop mode at the end of deceleration</p> <p>This parameter can only be accessed if StY = -d- and if the CLP parameter in the drive menu (drC) is still set to the factory setting (On). Can be used to set the final torque level between 0 and 100% of the estimated torque at the start of deceleration. In pump applications, deceleration control is not necessarily effective below a load level set by Edc. If the estimated torque at the start of deceleration is below 20, i.e. 20% of the nominal torque, controlled deceleration is not activated, and the motor changes to freewheel mode.</p>  <p style="text-align: center;">Estimated torque as a % of the nominal torque</p>	0 to 100%	20%

Settings menu (Set)

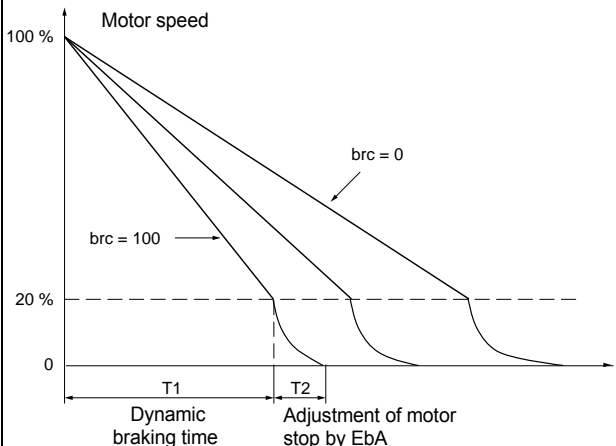
Code	Description	Setting range	Factory setting
b r C	<p>Internal braking torque level</p> <p>This parameter can only be accessed if StY = -b-. For stop type -b-, used to adjust the braking intensity.</p> <p>Braking is active up to 20% of the nominal speed. The total stop of the motor is configured by adjusting the injection time of the pseudo-continuous current in the motor (on two phases). See the next parameter EbA.</p>  <p>Pseudo-continuous injection time: $T2 = T1 \times EbA$</p> <p>Note: Time T1 is not determined by brC. T1 is the time required in seconds for the motor to fall from 100% of the nominal speed to 20% (depends on the motor and application characteristics).</p>	0 to 100%	50%
E b A	<p>Pseudo-continuous braking time</p> <p>This parameter can only be accessed if StY = -b-. For stop type -b-, adjustment of the current injection time at the end of braking. Can be used to adjust the current injection time. Can be set at 20 to 100% of the dynamic braking time (T1).</p> <p>Example: Dynamic braking = 10 s (T1) The stopping time can vary from 2 to 10 s (T2)</p> <p>EbA = 20 Corresponds to an injection time of 2 s EbA = 100 Corresponds to an injection time of 10 s</p> <p>Factory setting: 20</p>	20 to 100%	20%

Protection menu (PrO)

ENGLISH

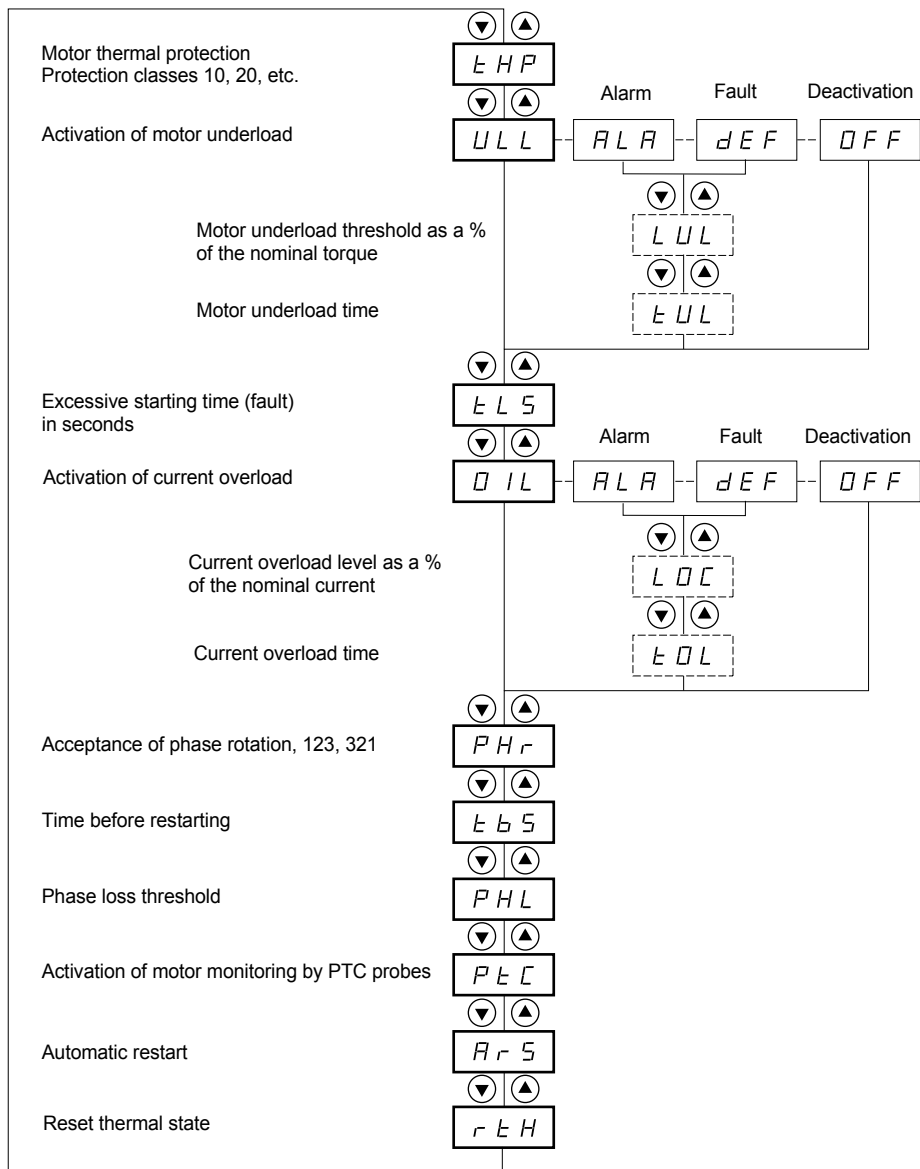

- Parameters in menu
- Can be selected
- Parameter appears according to selection

To access the parameters, see page 128.

Protection menu (PrO)

The protection parameters can only be modified when the motor is stopped.

Code	Description	Setting range	Factory setting
t HP	Motor thermal protection		10
	See "Thermal protection", page 123. 30: class 30 25: class 25 20: class 20 (severe application) 15: class 15 10: class 10 (standard application) 10A: class 10A 2: sub-class 2 OFF: no protection		
ULL	Activation of motor underload		OFF
	If the motor torque is less than an adjustable threshold LUL for a period of time longer than an adjustable value tUL: - ALA: an alarm is activated (internal bit and configurable logic output) - dEF: the starter is locked and the ULF fault is displayed - OFF: no protection		
	<p>The graph plots torque T (Cn) on the y-axis against time t on the x-axis. The nominal torque is 100%. A horizontal line represents the Motor Underload Limit (LUL). A hysteresis band is shown above LUL, with a +10% margin. The torque curve starts at 100%, dips below LUL for a duration labeled <math>t_{UL}</math>, then rises back above LUL. The time from the start of the dip to the end of the hysteresis band is labeled <math>< t_{UL}</math>. The time from the end of the hysteresis band to the point where the torque reaches the ULL (Underload Limit) is labeled <math>t_{UL}</math>. The ULL is shown as a dashed line at 20% torque. The detection time is marked as 'detection'.</p>		
L UL	Motor underload threshold	20% to 100% of Tn	60%
	This parameter is not available if ULL = OFF. LUL can be set at between 20% and 100% of the nominal motor torque.		
t UL	Motor underload time	1 to 60 s	60 s
	This parameter is not available if ULL = OFF. Time delay tUL is activated as soon as the motor torque falls below threshold LUL. It is reset to zero if the torque rises above this threshold LUL by + 10% (hysteresis).		
t L 5	Excessive starting time	10 to 999 s or OFF	OFF
	If the starting time exceeds the value of tLS, the starter is locked and displays the fault StF. The conditions for the end of starting are: line voltage applied to the motor (min. firing angle) and motor current less than 1.3 In. - OFF: no protection		



The configuration of a monitoring alarm (ALA) indicates the presence of a fault but will not directly protect the installation

Protection menu (PrO)

Code	Description	Setting range	Factory setting
0 IL	Activation of current overload		OFF
	<p>Function active only in steady state If the motor current exceeds an adjustable threshold LOC for a period of time longer than an adjustable value tOL:</p> <ul style="list-style-type: none"> - ALA: an alarm is activated (internal bit and configurable logic output) - dEF: the starter is locked and the OLC fault is displayed - OFF: no protection 		
	<p style="text-align: center;">detection OIL</p>		
L OL	Current overload threshold	50% to 300% of In	80%
	<p>This parameter is not available if OIL = OFF. LOC can be set at between 50% and 300% of the nominal motor current.</p>		
t OL	Current overload time	0.1 to 60 s	10 s
	<p>This parameter is not available if OIL = OFF. Time delay tOL is activated as soon as the motor current rises above threshold LOC. It is reset to zero if the current falls below this threshold LOC again by at least 10% (hysteresis).</p>		



The factory configuration of a monitoring alarm (ALA) indicates the presence of a fault but will not directly protect the installation

Protection menu (PrO)

Code	Description	Setting range	Factory setting
<i>PHr</i>	Protection against line phase inversion	321 or 123 or no	no
	If the line phases are not in the order configured, the starter locks and displays the fault PIF. - 321: reverse (L3 - L2 - L1) - 123: forward (L1 - L2 - L3) - no: no monitoring		
<i>tbS</i>	Time before starting	0 to 999 s	2 s
	Avoids starts in quick succession which may overheat the motor. The time delay starts when the motor changes to freewheel mode. In 2-wire control, the motor is restarted after the time delay if the RUN command input is still activated. In 3-wire control, the motor is restarted after the time delay if a new RUN command is sent (rising edge). The starter displays "tbS" during the time delay.		
<i>PHL</i>	Phase loss threshold	5 to 10%	10%
	If the motor current falls below this threshold in one phase for 0.5 s or in all three phases for 0.2 s, the starter locks and displays the fault PHF. Can be set at between 5 and 10% of the ICL starter rating.		
<i>PtC</i>	Activation of motor monitoring by PTC probes		OFF
	The PTC probes on the motor must be connected to the correct analog input. This protection is independent of the calculated thermal protection (tHP parameter). Both types of protection can be used simultaneously. - ALA: an alarm is activated (internal bit and assignable logic output) - dEF: the starter is locked and the OtF fault is displayed - OFF: no protection		
<i>RrS</i>	Automatic restart	On - OFF	OFF
	After locking on a fault, if the fault has disappeared and the other operating conditions permit the restart. A series of automatic attempts are made to restart the starter at intervals of 60 s. If a restart has not been possible after 6 attempts, the procedure is abandoned and the starter remains locked until it is switched off then switched on again or reset manually (see "Faults - causes - remedies" page 159). The following faults permit this function: PHF, FrF, CLF, USF. The starter fault relay remains activated if this function is active. The run command must be maintained. This function can only be used in 2-wire control. - OFF: Function inactive - On: Function active  Check that an accidental start will not endanger personnel or equipment in any way		
<i>rLH</i>	Reset motor thermal state calculated by the starter	no - YES	no
	- no: Function inactive - YES: Function active		



The factory configuration of a monitoring alarm (ALA) indicates the presence of a fault but will not directly protect the installation

Advanced settings menu (drC)

	▼ ▲
Torque limit as a % of the nominal torque	ELI
	▼ ▲
Voltage boost level	bSt
	▼ ▲
Starter with delta winding connection	dLt
	▼ ▲
Tests on small motor	SSt
	▼ ▲
Torque control	CLP
	▼ ▲
Stator loss compensation	LSC
	▼ ▲
Deceleration gain	tIG
	▼ ▲
Activation of the cascade function	CSC
	▼ ▲
Line voltage (to calculate P in kW)	ULn
	▼ ▲
Line frequency	Frc
	▼ ▲
Reset kWh or the operating time	rPr
	▼ ▲
Return to factory settings	FCS

 Parameters in menu

Advanced settings menu (drC)

The Advanced setting parameters can only be modified when the motor is stopped.

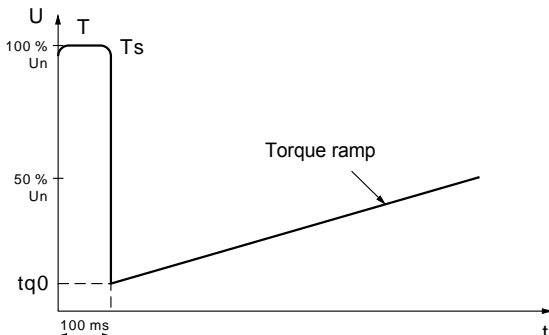
Code	Description	Setting range	Factory setting
t L l	Torque limit	10 to 200% or OFF	OFF
	<p>Can be used to limit the torque reference to avoid regenerative behaviour in applications with high inertia. Can be used for constant torque starting if tq0 = tLl.</p> <p>- OFF: no limit - 10 to 200: limit set as a % of the nominal torque</p>		
b 5 t	Voltage boost level	50 to 100% or OFF	OFF
	<p>An adjustable voltage can be applied when a run command is present for 100 ms. Once this time has elapsed, the starter follows a standard acceleration ramp starting at the initial torque value set (tq0).</p> <p>This function can be used to avoid any "starting" torque (phenomenon caused by friction on stopping or by mechanical play).</p> <p>- OFF: Function inactive - 50 to 100: setting as a % of the nominal motor voltage</p>  <p>! In the case of overrating the starter ($I_m \text{ motor} > I_m \text{ ATS48}$), a value of the parameter bSt too high can cause the starter to trip in OCF</p>		
d L t	Starter with delta winding connection	on - OFF	OFF
	<p>This configuration will permit a rating increase of 1.7 in the starter power but does not permit braking or deceleration.</p> <p>- OFF: normal line torque - On: motor with delta winding connection</p> <p>The nominal motor current I_n is the same as that specified on the motor rating plate and the current displayed corresponds to the line current of the line supply. The nominal current value I_n (SEt menu) is the same as that specified on the motor rating plate for the delta connection. The starter carries out the conversion itself to control the current in the windings.</p> <p>This parameter can only be accessed for ATS 48...Q or ATS 48... YS316 starters.</p> <p>!</p> <ul style="list-style-type: none"> • With this function, dynamic braking stop is not possible. • Cascading is not possible • Preheating is not possible • The wiring diagram page 115 must be respected 		

Advanced settings menu (drC)

Code	Description	Setting range	Factory setting
55L	Tests on small motor	On - OFF	OFF
	<p>To check the starter in a testing or maintenance environment, on a motor whose power is very much lower than the starter rating (in particular for high power starters). The torque control parameter CLP is automatically deactivated.</p> <ul style="list-style-type: none"> - OFF: function inactive - On: function active <p>Note:</p> <ul style="list-style-type: none"> • SSt returns to the OFF state as soon as the control voltage is disconnected. On the next power up, the PHF fault and the CLP parameter return to their initial configuration. • SST is only dedicated for maintenance and testing of the starter. 		
CLP	Torque control (type of control)	On-OFF	On
	<ul style="list-style-type: none"> - OFF: function inactive - On: function active <p>In the On position, starting and deceleration follow the torque ramp. In the OFF position, starting and deceleration are controlled by voltage variation. Voltage control is recommended for applications which use motors in parallel on one starter or a motor whose power is very low in relation to the starter rating (use of an undersized motor to test the starter) (CLP = OFF).</p>		
L5C	Stator loss compensation	0 to 90%	50%
	<p>Parameter active in acceleration phases (and deceleration phases if StY = -d-). In the event of torque oscillations, reduce this parameter gradually until the device is functioning correctly. Oscillations are most common if the starter is connected in the motor delta winding or in motors with excessive slip.</p>		
EIG	Deceleration gain (for torque control)	10 to 50%	40%
	<p>This parameter can only be accessed if CLP = On and if the StY parameter (SEt Settings menu) = -d-. Can be used to eliminate instability during deceleration. Adjust the parameter in accordance with the oscillations.</p>		
L5C	Activation of the cascade function	On-OFF	OFF
	<p>See page 122</p> <ul style="list-style-type: none"> - On: function active - OFF: function inactive <p>This parameter can only be accessed if relay R1 has previously been assigned to the "isolating relay" function and if the "forced freewheel stop", "starter in the motor delta winding" and "preheating" functions are not configured. Assign an input LI = LIC. 255 motors max.</p>		
ULn	Line voltage	170 to 460 V (ATS48••Q) 180 to 790 V (ATS48••Y)	400 V (ATS48••Q) 460 V (ATS48••Y)
	<p>This parameter is used to calculate the power displayed (LPr and LAP parameters from the SUP menu). The display will only be accurate if this parameter has been set correctly.</p>		

Advanced settings menu (drC)

Code	Description	Adjustment range	Factory setting
<i>FrL</i>	Line frequency - 50: 50 Hz (monitoring tolerance of frequency fault FrF = ± 20%). - 60: 60 Hz (monitoring tolerance of frequency fault FrF = ± 20%). - AUt: automatic recognition of the line frequency by the starter with frequency fault monitoring tolerance FrF = ± 5%. Selections 50 and 60 are recommended if the power supply is provided by a generating set, given their high tolerance.	50-60-AUt	AUt
<i>rPr</i>	Reset kWh or the operating time - no: function inactive - APH: kWh reset to zero (1) - trE: operating time reset to zero The reset command must be confirmed with ENT. APH and trE take effect immediately. The parameter then automatically returns to no.	no-APH-trE	no
<i>FL5</i>	Return to factory settings Used to reset all parameters to their factory settings. - no: function inactive - YES: function active, must be pressed and held down (for approx. 2 s) in order to be taken into account. The display flashes to confirm. The FCS parameter is then automatically reset to no by pressing ESC. This parameter cannot be modified via the remote terminal.	no-YES	no

(1) This information « kWh consumed » is only visible with the PowerSuite software workshop or online with Modbus (address W4074).

I/O menu (IO)

ENGLISH

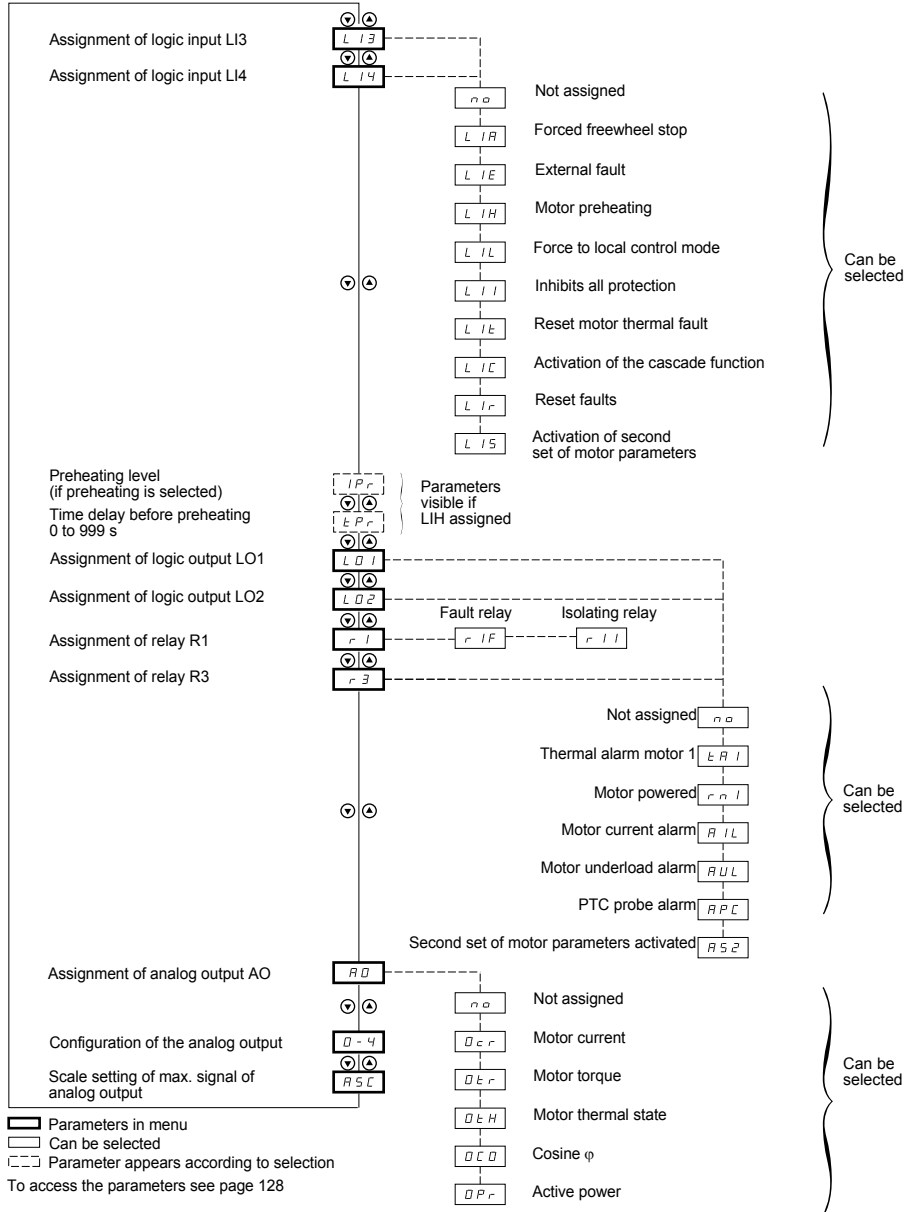

I/O menu (IO)

The I/O parameters can only be modified when the motor is stopped.

Code	Description	Setting range	Factory setting
L 13 L 14	<p>Logic inputs</p> <p>The selected function is active if the input is powered up.</p> <ul style="list-style-type: none"> - no: not assigned. - LIA: forced freewheel stop as soon as a STOP command is received. This selection does not appear if the CSC parameter in the drC menu is set to "On". Forces the configuration of a freewheel type stop, but does not control the stop. - LIE: external fault. Enables the starter to detect an external user fault (level, pressure, etc.). The motor comes to a freewheel stop and the starter displays EtF. - LIH: (1) motor preheating. This selection does not appear if the CSC parameter in the drC menu is set to "On". Used to prevent the motor from freezing or to prevent temperature deviations which may cause condensation. Once the motor has stopped an adjustable current IPr flows through it after an adjustable time delay tPr, if the input is active. This current heats the motor without causing it to rotate. IPr and tPr must be adjusted (see below). <p>Preheating starts when the input is activated and the motor has stopped, after time delays tPr and tbS (PrO menu) have elapsed. Preheating stops if the input is deactivated, if a run command is sent or if the STOP input is activated.</p> <ul style="list-style-type: none"> - LIL: force to local control mode. If a serial link is used, changes from line mode (control via serial link) to local mode (control via terminals). - LII: (1) inhibits all protection. Warning: This type of use invalidates the starter warranty. Used to override the starter in the event of an emergency (smoke extraction system for example). - LIt: reset motor thermal fault - LIC: activation of the cascade function. In this case motor thermal protection is disabled and relay R1 must be configured as an isolating relay. Can be used to start and decelerate several identical motors one after the other with a single starter (see application diagram). - LIr: reset faults which can be reset - LIS: activation of second set of motor parameters. Used to start and decelerate two different motors one after the other or one motor with two different configurations using a single starter. 		LIA LIL

(1) In order for this assignment to take effect, ENT must be pressed for 10 s (confirmed by flashing display).
This parameter cannot be modified via the remote terminal.

I/O menu (IO)

Code	Description	Setting range	Factory setting
<i>IPr</i>	Preheating level	0 to 100%	0%
	<p>This parameter appears after LI3 or LI4 have been assigned to function LIH: motor preheating. It can be used to set the preheating current. Use a true value current reading ammeter to set the motor current level. Parameter In has no effect on the current IPr.</p> <div style="border: 1px solid black; padding: 5px; text-align: center;"> <p>CAUTION</p> <p>RISK OF DAMAGE TO THE MOTOR If the line frequency is fluctuating, it is mandatory to use an external device to monitor the frequency and switch off the preheating function in case of fluctuations. Failure to follow these instructions can result in equipment damage.</p> </div>		
<i>tPr</i>	Time delay before preheating	0 to 999 mn	5 mn
	<p>This parameter appears after LI3 or LI4 have been assigned to function LIH: motor preheating. Preheating starts when the input is activated, after time delays tPr and tbS (PrO menu) have elapsed.</p>		
<i>L01</i> <i>L02</i>	Logic outputs		tAl rnl
	<ul style="list-style-type: none"> - no: not assigned. - tAl: motor thermal alarm. See page 123. - rnl: motor powered (indicates that there may be current in the motor). - AIL: motor current alarm (threshold OIL and time tOL of PrO menu exceeded). See "Function active only in steady state", page 138. - AUL: motor underload alarm (threshold LUL and time tUL of PrO menu exceeded). See page 137. - APC: motor PTC probe alarm. See "Activation of motor monitoring by PTC probes", page 139. - AS2: second set of motor parameters activated. See LIS "Logic inputs", page 145. 		
<i>r1</i>	Relay R1		r1F
	<ul style="list-style-type: none"> - r1F: fault relay. Relay R1 is activated when the starter is powered up (minimum CL1/CL2 control). Relay R1 is deactivated when a fault occurs and the motor switches to freewheel mode. See the special case when the automatic restart function is activated and Faults - causes - remedies page 160 to 164. - r1I: isolating relay. Relay R1 is designed to control the line contactor on the basis of the RUN and STOP commands and to indicate faults. Relay R1 is activated by a RUN command (or a preheating command). It is deactivated at the end of braking or deceleration or when the motor switches to freewheel mode after a STOP command. It is also deactivated when a fault occurs. The motor switches to freewheel mode at this point. 		
r3	Relay R3		rnl
	<ul style="list-style-type: none"> - no: not assigned. - tAl: motor thermal alarm. See page 123. - rnl: motor powered (indicates that there may be current in the motor). - AIL: motor current alarm (threshold OIL and time tOL of PrO menu exceeded). See "Function active only in steady state", page 138. - AUL: motor underload alarm (threshold LUL and time tUL of PrO menu exceeded). See page 137. - APC: motor PTC probe alarm. See "Activation of motor monitoring by PTC probes", page 139. - AS2: second set of motor parameters activated. See LIS "Logic inputs", page 145. 		

End of starting relay R2 (cannot be assigned)

















The end of starting relay R2 is activated when the starter is powered up, no faults are present and the motor has completed the start-up phase. It is deactivated in the event of a stop request or a fault. It has one normally open contact (N/O).

It can be used to bypass the ATS 48 at the end of the starting phase.

Code	Description	Setting range	Factory setting
R0	Analog output		OCr
	- no: not assigned - OCr: motor current - Otr: motor torque - OtH: motor thermal state - OCO: cosine φ - OPPr: active power		
D4	Configuration of the type of signal supplied by output AO	020 - 420	020
	- 020: 0 - 20 mA signal - 420: 4 - 20 mA signal		
R5C	Scale setting of max. signal of the analog output	50 to 500%	200
	As a percentage of the nominal value of the parameter configured or of 1 for the cosine φ .		

2nd motor parameters menu (St2)

The parameters for 1st or 2nd motor are selected by the logic input (LIS). Taking into account the motor parameters selected :

Nominal motor current	  In 2	On the next acceleration
Limiting current	  IL 2	Immediately
Acceleration ramp time	  AC 2	On the next acceleration
Initial starting torque	  t 9 2	On the next acceleration
Deceleration ramp time	  dE 2	On the next deceleration
Threshold for changing to freewheel stop mode at the end of deceleration	  Ed 2	On the next deceleration
Maximum torque limiting	  tL 2	Immediately
Deceleration gain	  tI 2	On the next deceleration

 Parameters in menu

 Parameter appears according to the selection and to the assignment of StY in the SEt menu

2nd motor parameters menu (St2)

This menu is only visible if a logic input is assigned to the function for activating a second set of motor parameters (LIS) in the I/O menu.

Code	Description	Setting range	Factory setting
<i>In2</i>	Nominal motor current	0.4 to 1.3 ICL	(1)
	Adjust the value of the nominal motor current indicated on the rating plate, even if the starter is connected in the motor delta winding (PrO). Check that the current is between 0.4 and 1.3 ICL (ICL: starter rating). See "Starter-motor combinations", page 96.		
<i>IL2</i>	Limiting current	150 to 700% of In, limited to 500% of ICL	400% of In
	The limiting current IL2 is expressed as a % of In2. It is limited to 500% of ICL (starter rating, see "Starter-motor combinations", page 96). Limiting current = IL2 x In2 Example 1: In2 = 21 A, IL2 = 300%, limiting current = 300% x 22 A = 66 A Example 2: ATS 48C21Q, with ICL = 210 A In2 = 195 A, IL2 = 700%, limiting current = 700% x 195 = 1365, limited to 500% x 210 = 1050 A		
<i>RL2</i>	Acceleration ramp time	1 to 60 s	15 s
	This is the rise time of the starter torque between 0 and the nominal torque Tn, i.e. the gradient of the torque ramp on acceleration.		
	<p>The graph illustrates the acceleration ramp time. The vertical axis is labeled 'Reference torque as a % of Tn' and has a scale from 0 to 100 in increments of 20. The horizontal axis is labeled 'Time (s)' and has a scale from 0 to AC2. A solid line starts at the origin (0,0) and rises linearly to the point (AC2, 100). Dashed lines are used to indicate the coordinates of this point: a vertical dashed line from AC2 on the x-axis to the line, and a horizontal dashed line from that point to 100 on the y-axis.</p>		

(1) Factory setting of In2 corresponding to the usual value of a 4-pole 400 V standardised motor with class 10 protection (for ATS 48***Q).

Factory setting of In2 corresponding to the usual value of a 460 V standardised motor in accordance with NEC and with class 10 protection (for ATS 48***Y).

2nd motor parameters menu (St2)

ENGLISH

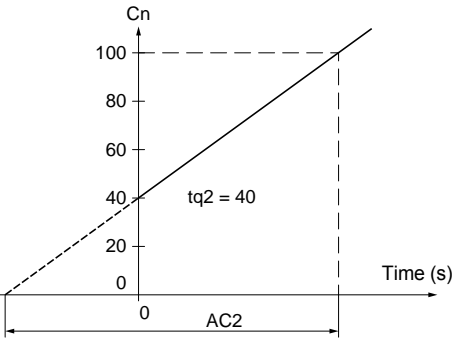
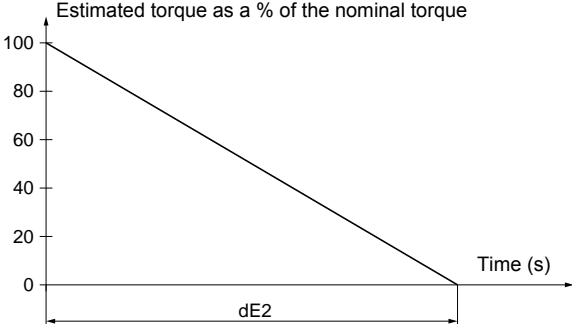
Code	Description	Setting range	Factory setting
t 92	Initial starting torque Initial torque setting during the starting phases, varies from 0 to 100% of the nominal torque. 	0 to 100% of Tn	20%
dE2	Deceleration ramp time This parameter can only be accessed if StY = -d-. Used to set a time between 1 to 60 s to switch from the estimated torque to zero torque (= gradient of the torque ramp on deceleration when a -d- stop is applied). This modifies the progression of the deceleration and avoids hydraulic shocks in pump applications by modifying the gradient of the torque reference. 	1 to 60 s	15 s

2nd motor parameters menu (St2)

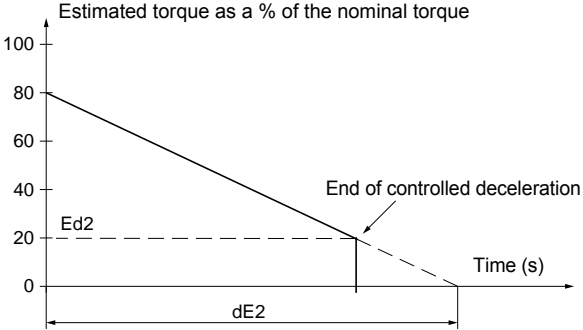
Code	Description	Setting range	Factory setting
Ed2	Threshold for changing to freewheel stop mode at the end of deceleration	0 to 100%	20%
	<p>This parameter can only be accessed if StY = -d- and if the CLP parameter in the drive menu (drC) is still set to the factory setting (On). Used to set the final torque level between 0 and 100% of the torque estimated at the beginning of deceleration. In pump applications, deceleration control is not necessarily below a load level set by Ed2. If the estimated torque at the start of deceleration is below 20, i.e. 20% of the nominal torque, controlled deceleration is not activated, and the motor changes to freewheel mode.</p> 		
tL2	Maximum torque limit	10 to 200% or OFF	OFF
	<p>Used to limit the torque reference to avoid regenerative behaviour in applications with high inertia. Can be used for constant torque starting if tq2 = tL2. - OFF: no limit - 10 to 200: limit set as a % of the nominal torque</p>		
tI2	Deceleration gain (for torque control)	10 to 50%	40%
	<p>This parameter can only be accessed if CLP = On and if the StY parameter (SEt Settings menu) = -d-. Used to eliminate instability during deceleration. Adjust the parameter in accordance with the oscillations.</p>		

Communication menu (COP)

ENGLISH

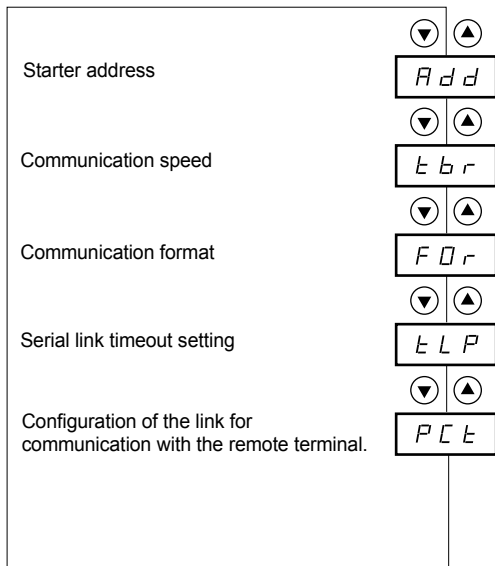

 Parameters in menu

Communication menu COP

The communication menu parameters can only be modified when the motor is stopped.
The internal protocol used is Modbus.

Code	Description	Setting range	Factory setting
<i>R d d</i>	Starter address by the RS485 serial link	0 to 31	0
<i>t b r</i>	Communication speed in kbps.	4.8 - 9.6 - 19.2	19.2
<i>F O r</i>	Communication format 8o1: 8 data bits, odd parity, 1 stop bit 8E1: 8 data bits, even parity, 1 stop bit 8n1: 8 data bits, no parity, 1 stop bit 8n2: 8 data bits, no parity, 2 stop bits		8n1
<i>t L P</i>	Serial link timeout setting (1)	0.1 to 60 s	5 s
<i>P C t</i>	Configuration of the serial link for communication with the remote terminal On: function active. Temporarily configures the starter (tbr and FO _r) for communication with the remote terminal, to be used in case of tbr and FO _r a not a factory value. OFF : Temporary configuration function inactive. PCT returns to the OFF state as soon as the control voltage is disconnected. On the next power up, the tbr and FO_r parameters return to their initial configuration.		OFF



(1) Check that the time set will not interfere with the safe operation of the machine

Parameter displayed menu (SUP)

ENGLISH

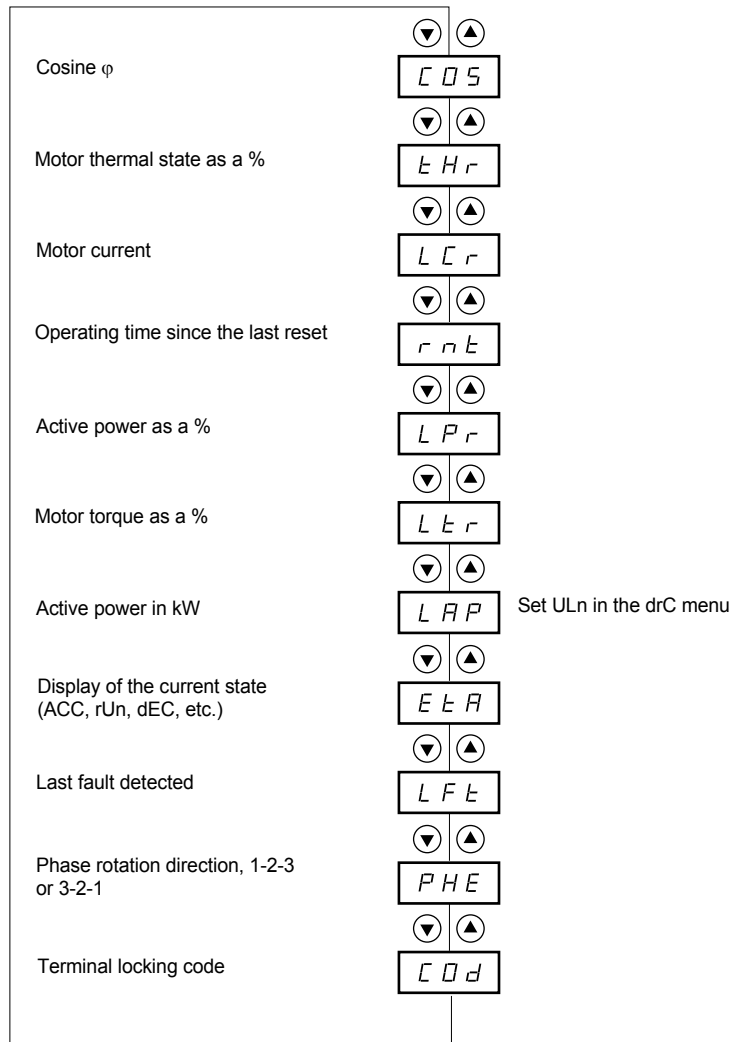

Parameters in menu

Parameter displayed menu (SUP)

The parameter to be displayed can be modified with the motor stopped or running.

The factory setting displays the motor current (parameter LCr).

The display chosen is saved by:

- Pressing the ENT key once: the choice is temporary, it will be cleared at the next power up.
- Pressing the ENT key again for 2 seconds: the display flashes, the choice is permanent and cannot be modified.

Code	Parameter	Unit
L D 5	Cosine φ	0.01
t H r	Motor thermal state Varies from 0 to 125% 100% corresponds to the nominal thermal state for the current In set.	%
L C r	Motor current In amperes up to 999 A (examples: 01.5 = 1.5 A; 15.0 = 15 A; 150 = 150 A) In kiloamperes starting at 1000 A (examples: 1.50 = 1500 A; 1.15 = 1150 A)	A or kA
r n t	Operating time in hours since the last reset. In hours up to 999 hrs (examples: 001 = 1 hr; 111 = 111 hrs) In kilo-hours from 1000 to 65535 (examples: 1.11 = 1110 hrs; 11.1 = 11100 hrs) Above 65535 hrs (65.5) the display is reset to zero. Operating time is counted when the motor is not stopped, i.e. when the thyristors are fired (heating, acceleration, steady state, deceleration, braking) and in continuous bypass operation. The hour counter can be reset in line mode using the control word or via the terminal with the motor stopped. When the control part is switched off the hour counter is saved in the EEPROM.	h or kh
L P r	Active power Varies from 0 to 255% 100% corresponds to the power at nominal current and at full voltage.	%
L t r	Motor torque Varies from 0 to 255% 100% corresponds to the nominal torque.	%
L R P	Active power in kW This parameter requires configuration of the exact value of the line voltage ULn in the drC menu.	kW
E t A	Display of the current state <ul style="list-style-type: none"> - nLP: starter without run command and power not supplied - rdY: starter without run command and power supplied - tbS: starting time delay not elapsed - ACC: acceleration in progress - dEC: deceleration in progress - rUn: steady state operation - brL: braking in progress - CLI: starter in current limiting mode - nSt : force to freewheel stop by serial link 	
L F t	Last fault detected (see page 159). If no faults have been saved, the display shows n 0 F . If faults have been inhibited, the display shows Inh .	
P H E	Phase rotation direction viewed from the starter <ul style="list-style-type: none"> - 123: forward (L1 - L2 - L3) - 321: reverse (L3 - L2 - L1) 	

Parameter displayed menu (SUP)

Code	Parameter
C D d	<p>Terminal locking code Enables the starter configuration to be protected using an access code.</p> <p> Caution: Before entering a code, do not forget to make a careful note of it</p> <ul style="list-style-type: none">• OFF: no access locking codes<ul style="list-style-type: none">- To lock access, enter a code (2 to 999). The display can be incremented using the ▲ key. Now press ENT. "On" appears on the screen to indicate that the parameters have been locked.• On: a code is locking access (2 to 999)<ul style="list-style-type: none">- To unlock access, enter the code (incrementing the display using the ▲ key) and press ENT. The code remains on the display and access is unlocked until the next power down. Parameter access will be locked again on the next power-up.- If an incorrect code is entered, the display changes to "On" and the parameters remain locked.• XXX: parameter access is unlocked (the code remains on the screen).<ul style="list-style-type: none">- To reactivate locking with the same code when the parameters have been unlocked, return to "On" using the ▼ button then press ENT. "On" appears on the screen to indicate that the parameters have been locked.- To lock access with a new code when the parameters have been unlocked, enter a new code (increment the display using the ▲ or ▼ keys) and press ENT. "On" appears on the screen to indicate that the parameters have been locked.- To clear locking when the parameters have been unlocked, return to "OFF" using the ▼ button and press ENT. "OFF" remains on the screen. The parameters are unlocked and will remain unlocked until the next restart.

When access is locked using a code, only the monitoring parameters can be accessed, with only a temporary choice of parameter displayed.

Compatibility table

The choice of application functions can be limited by the incompatibility between certain functions. The functions that are not listed in the table are not incompatible with any other functions.

Functions	Soft stop	Dynamic braking stop	Force freewheel stop	Thermal protection	Loss of a motor phase	Connecting to "delta in the motor"	Test on small motor	Cascade	Preheating
Soft stop	Compatible	Incompatible	Compatible	Compatible	Compatible	Compatible	Compatible	Compatible	Compatible
Dynamic braking stop	Incompatible	Compatible	Compatible	Compatible	Compatible	Incompatible	Compatible	Compatible	Compatible
Force freewheel stop	Compatible	Compatible	Compatible	Compatible	Compatible	Compatible	Compatible	Incompatible	Compatible
Thermal protection	Compatible	Compatible	Compatible	Compatible	Compatible	Compatible	Compatible	Incompatible	(2)
Loss of a motor phase	Compatible	Compatible	Compatible	Compatible	Compatible	Compatible	Compatible	Compatible	Incompatible
Connecting to "delta in the motor"	Compatible	Incompatible	Compatible	Compatible	Compatible	Compatible	Incompatible	Incompatible	Incompatible
Test on small motor	Compatible	Compatible	Compatible	Compatible	Compatible	Incompatible	Compatible	Incompatible	Compatible
Cascade	Compatible	Compatible	Incompatible	Incompatible	Compatible	Incompatible	Incompatible	Compatible	Incompatible
Preheating	Compatible	Compatible	Compatible	(2)	Incompatible	Incompatible	Compatible	Incompatible	Compatible

Compatible functions
Incompatible functions
Not significant

(1) Motor phase loss not detected

(2) While motor's preheating, the thermal protection is not assured. Set the preheating current IPr.

Maintenance

Servicing

The Altistart 48 does not require any preventative maintenance. It is nevertheless advisable to perform the following regularly:

- Check the condition and tightness of connections
- Ensure that the temperature around the unit remains at an acceptable level and that ventilation is effective (average service life of fans: 3 to 5 years depending on the operating conditions)
- Remove any dust from the heatsink if necessary

Assistance with maintenance

If a problem arises during setup or operation, ensure that the recommendations relating to the environment, mounting and connections have been observed.

The first fault detected is memorized and displayed on the screen: the starter locks and relays R1 and R2 change state according to their assignment.

Clearing the fault

Switch off the starter power supply in the event of a fault which cannot be reset.

Wait for the display to go off completely.

Find the cause of the fault in order to correct it.

Restore the power supply: this clears the fault if it has disappeared.

In some cases there may be an automatic restart once the fault has disappeared if this function has been programmed.

Monitoring menu

This is used to prevent and find the causes of faults by displaying the starter status and its current values.

Spares and repairs

Consult Schneider Electric product support.

Faults - causes - remedies

As a general rule, if a problem arises when the starter is started, it is advisable to return to the factory settings and repeat your settings step by step.

Starter does not start, no fault displayed

- No display: check that the line supply is present on the control supply CL1/CL2 (see page 111).
- Check that the code displayed does not correspond to the normal state of the starter (see page 129).
- Check for the presence of the RUN/STOP commands (see page 112).

Faults which cannot be reset

When this type of fault appears the starter locks and the motor switches to freewheel mode.

Signalling:

- Opening of end of starting relay R2
- Opening of relay R1 (following starter locking)
- Fault code flashes on the display
- Storing of the last 5 faults, visible with the PowerSuite software workshop

Restart conditions:

- Disappearance of the causes of the fault
- Disconnection and reconnection of the control supply

Fault displayed	Probable cause	Procedure, remedy
<i>I n F</i>	Internal fault	Disconnect and reconnect the control supply. If the fault persists, contact Schneider Electric product support.
<i>□ C F</i>	Overcurrent: <ul style="list-style-type: none">• impeding short-circuit on starter output• internal short-circuit• bypass contactor stuck• overrate starter	Switch the starter off. <ul style="list-style-type: none">• Check the connecting cables and the motor isolation• Check the thyristors• Check the bypass contactor (contact stuck)• Check the parameter value bSt in the menu drC page 141
<i>P I F</i>	Phase inversion Line phase inversion does not conform to the selection made by PHr in the Protection menu.	Invert two line phases or set PHr = no
<i>E E F</i>	Internal memory fault	Disconnect and reconnect the control supply. If the fault persists, contact Schneider Electric product support.

Faults which can be reset as soon as their causes disappear

When this type of fault appears the starter locks and the motor switches to freewheel mode.

Signalling:

- Opening of end of starting relay R2.
- Opening of relay R1 only if it is configured as an isolating relay.
- The fault code flashes on the display as long as the fault is present.
- Storing of the last 5 faults, visible with the PowerSuite software workshop.

Restart conditions:

- Disappearance of the causes of the fault.
- In 2-wire control the run command must be maintained on the RUN input.
- In 3-wire control a new run command (rising edge) is required on the RUN input.

Fault displayed	Probable cause	Procedure, remedy
<i>CF F</i>	Invalid configuration on power-up	<ul style="list-style-type: none">• Revert to the factory setting in the drive menu drC.• Reconfigure the starter.
<i>CF I</i>	Invalid configuration The configuration loaded in the starter via the serial link is incompatible.	<ul style="list-style-type: none">• Check the configuration loaded previously.• Load a compatible configuration.

Faults which can be reset manually and can generate an automatic restart

(1)

When this type of fault appears the starter locks and the motor switches to freewheel mode.

Signalling with automatic restart:

- Opening of end of starting relay R2
- Opening of relay R1 only if it is configured as an isolating relay. R1 remains closed if it is configured as a fault relay, see page 146
- The fault code flashes on the display as long as the fault is present
- Storing of the last 5 faults, visible with the PowerSuite software workshop

Restart conditions for the following faults with automatic restarting (in 2-wire control only):

- Disappearance of the causes of the fault
- Run command maintained on the RUN input
- 6 restart attempts are carried out at intervals of 60 seconds. At the 6th attempt if the fault is still present it trips requiring a manual reset (see following page) and R1 opens if it is configured as a fault relay

Fault displayed	Probable cause	Procedure, remedy
<i>FrF</i> (2)	Line frequency, out of tolerance This fault can be configured in the Advanced settings menu drC, parameter FrC.	<ul style="list-style-type: none"> • Check the line. • Check that the configuration of the FrC parameter is compatible with the line used (generating set for example).
<i>PHF</i> (3)	<p>Loss of a line phase</p> <p>Loss of a motor phase If the motor current falls below an adjustable threshold PHL in one phase for 0.5 s or in the three phases for 0.2 s. This fault can be configured in the Protection menu PrO, parameter PHL.</p>	<ul style="list-style-type: none"> • Check the line, the frequency stability, the connection to the starter and any devices located between the line and the starter (contactor, fuses, circuit-breaker, etc.). • If bypass contactor is used, check the mechanism (wear, mechanical play, lubrication, blockages...) • Check the motor connection (T1, T2, T3 terminal) and any isolating devices located between the starter and the motor (contactors, circuit-breakers, etc.). • Check the motor state. • Check that the configuration of the PHL parameter is compatible with the motor used.

(1) If the automatic restart function is not selected, see page 163 for the signalling and restart conditions of these faults.

(2) After each Power ON of the control supply, the FrF detection is done only at the first power ON of the main supply.

(3) For next Power ON of the main supply, bad frequency will also generate a desynchronization fault PHF.

Faults - causes - remedies

Faults which can be reset manually and can generate an automatic restart

(1)

When this type of fault appears the starter locks and the motor switches to freewheel mode.

Restart conditions for the following faults:

- Disappearance of the causes of the fault
- Run command maintained (2-wire control only)

Fault displayed	Probable cause	Procedure, remedy
<i>U5F</i>	Power supply fault on a run command	<ul style="list-style-type: none">• Check the power supply circuit and voltage.
<i>CLF</i>	Control line failure	<ul style="list-style-type: none">• Loss of CL1/CL2 for more than 200 ms

(1) If the automatic restart function is not selected, see page 163 for the signalling and restart conditions of these faults.

Faults which can be manually reset only

When this type of fault appears the starter locks and the motor switches to freewheel mode.

Signalling:

- Opening of end of starting relay R2
- Opening of relay R1
- The fault code flashes on the display as long as the fault is present
- Storing of the last 5 faults, visible with the PowerSuite software workshop

Restart conditions:

- Disappearance of the causes of the fault
- A run command (2 or 3-wire control, requires a rising edge on the RUN input) to reset the fault (1)
- Another run command (2 or 3-wire control, requires a rising edge on the RUN input) to restart the motor

Fault displayed	Probable cause	Procedure, remedy
<i>5 L F</i>	Serial link fault	<ul style="list-style-type: none"> • Check the RS485 connection.
<i>E t F</i>	External fault	<ul style="list-style-type: none"> • Check the fault taken into account.
<i>5 t F</i>	Excessive starting time	<ul style="list-style-type: none"> • Check the mechanism (wear, mechanical play, lubrication, blockages, etc.). • Check the value of the tLs setting in the PrO menu page 137. • Check the sizing of the starter-motor in relation to the mechanical requirement.
<i>0 L t</i>	Current overload	<ul style="list-style-type: none"> • Check the mechanism (wear, mechanical play, lubrication, blockages, etc.). • Check the value of the LOC and tOL parameters in the PrO menu page 138.
<i>0 L F</i>	Motor thermal fault	<ul style="list-style-type: none"> • Check the mechanism (wear, mechanical play, lubrication, blockages, etc.). • Check the sizing of the starter-motor in relation to the mechanical requirement. • Check the value of the tHP parameter in the PrO menu page 137 and that of the In parameter in the SEt menu page 132. • Check the electrical isolation of the motor. • Wait for the motor to cool before restarting.
<i>0 H F</i>	Starter thermal fault	<ul style="list-style-type: none"> • Check the mechanism (wear, mechanical play, lubrication, blockages, etc.). • Check the sizing of the starter in relation to the motor and the mechanical requirement. • Check the operation of the fan (if the ATS48 used has one), ensuring that the air passage is not obstructed in any way and the heatsink is clean. Ensure that the mounting recommendations are observed. • Wait for the ATS48 to cool before restarting.

(1) A reset will not take place on a run command if LI is assigned to the "fault reset (LIr)" function.

Faults which can be manually reset only

Fault displayed	Probable cause	Procedure, remedy
<i>0 t F</i>	Motor thermal fault detected by the PTC probes	<ul style="list-style-type: none"> • Check the mechanism (wear, mechanical play, lubrication, blockages, etc.). • Check the sizing of the starter-motor in relation to the mechanical requirement. • Check the value of the PtC setting in the PrO menu page 139. • Wait for the motor to cool before restarting.
<i>UL F</i>	Motor underload	<ul style="list-style-type: none"> • Check the hydraulic circuit. • Check the value of the LUL and tUL parameters in the Pro protection menu page 137.
<i>L r F</i>	Locked rotor in steady state This fault is only active in steady state with starter bypass contactor. It is detected if the current in a phase is greater than or equal to 5 In for more than 0.2 s.	<ul style="list-style-type: none"> • Check the mechanism (wear, mechanical play, lubrication, blockages, etc.).
<i>E r r 7</i>	Only possible on the remote terminal: incorrect values for tbr and FOr	<ul style="list-style-type: none"> • Configured tbr = 19,2 and FOr = 8n1 or PCt = On see page 153

Reset faults using a logic input

If a logic input LI is configured as "reset motor thermal fault" or "reset faults which can be reset", the following conditions must be met:

- A pulse on logic input LI
- In 2-wire control the motor will restart if the run command is maintained on the RUN input
- In 3-wire control the motor will restart on a new run command (rising edge) on the RUN input

Configuration/Settings tables

ATS 48 starter.....
 Customer identification no.(if applicable).....
 Access code (if applicable).....

Settings menu *5 E t*

Code	Factory setting	Customer setting	Code	Factory setting	Customer setting
<i>I n</i>	(1)		<i>d E C</i>	15 s	
<i>I L t</i>	400%		<i>E d C</i>	20%	
<i>R C C</i>	15 s		<i>b r C</i>	50%	
<i>t 9 0</i>	20%		<i>E b A</i>	20%	
<i>5 t y</i>	-F-				

 The parameters in shaded boxes appear if the corresponding functions have been configured.

Protection menu *P r 0*

Code	Factory setting	Customer setting	Code	Factory setting	Customer setting
<i>t H P</i>	10		<i>t 0 L</i>	10.0	
<i>U L L</i>	OFF		<i>P H r</i>	no	
<i>L U L</i>	60%		<i>t b 5</i>	2 s	
<i>t U L</i>	60%		<i>P H L</i>	10%	
<i>t L 5</i>	OFF		<i>P t C</i>	OFF	
<i>0 I L</i>	OFF		<i>R r 5</i>	OFF	
<i>L 0 C</i>	80%		<i>r t H</i>	no	

 The parameters in shaded boxes appear if the corresponding functions have been configured.

(1) Depends on the starter rating.

Configuration/Settings tables

Advanced settings menu *d r C*

Code	Factory setting	Customer setting	Code	Factory setting	Customer setting
<i>ELI</i>	OFF		<i>L5C</i>	50%	
<i>b5t</i>	OFF		<i>tIG</i>	40%	
<i>dLt</i>	OFF		<i>C5C</i>	OFF	
<i>55t</i>	OFF		<i>ULn</i>	(1)	
<i>CLP</i>	On		<i>Frc</i>	AU	

 The parameters in shaded boxes appear if the corresponding functions have been configured.

I/O menu *IO*

Code	Factory setting	Customer setting	Code	Factory setting	Customer setting
<i>L13</i>	LIA		<i>r1</i>	r1l	
<i>L14</i>	LIL		<i>r3</i>	m1	
<i>IPr</i>	0%		<i>AO</i>	OCr	
<i>tPr</i>	5 mn		<i>D4</i>	020	
<i>LD1</i>	tA1		<i>ASL</i>	200	
<i>LD2</i>	rn1				

 The parameters in shaded boxes appear if the corresponding functions have been configured.

- (1) -ATS 48...Q: 400 V
-ATS 48...Y: 460 V

Configuration/Settings tables

2nd motor parameters menu St2

This menu is only visible if a logic input is assigned to the function for activating a second set of motor parameters (LIS) in the I/O menu.

Code	Factory setting	Customer setting	Code	Factory setting	Customer setting
<i>I n 2</i>	(1)		<i>d E 2</i>	15 s	
<i>I L 2</i>	400%		<i>E d 2</i>	20%	
<i>R C 2</i>	15 s		<i>t L 2</i>	OFF	
<i>t 9 2</i>	20%		<i>t I 2</i>	40%	

Communication menu COP

Code	Factory setting	Customer setting	Code	Factory setting	Customer setting
<i>R d d</i>	0		<i>t L P</i>	5 s	
<i>t b r</i>	19.2 kbps		<i>P C t</i>	OFF	
<i>F 0 r</i>	8n1				

(1) Depends on the starter rating.