

Serie **INOX-VAL**

Articolo **700014**

Full bore stainless steel AISI 316-CF8M ball valve, F/F threading.

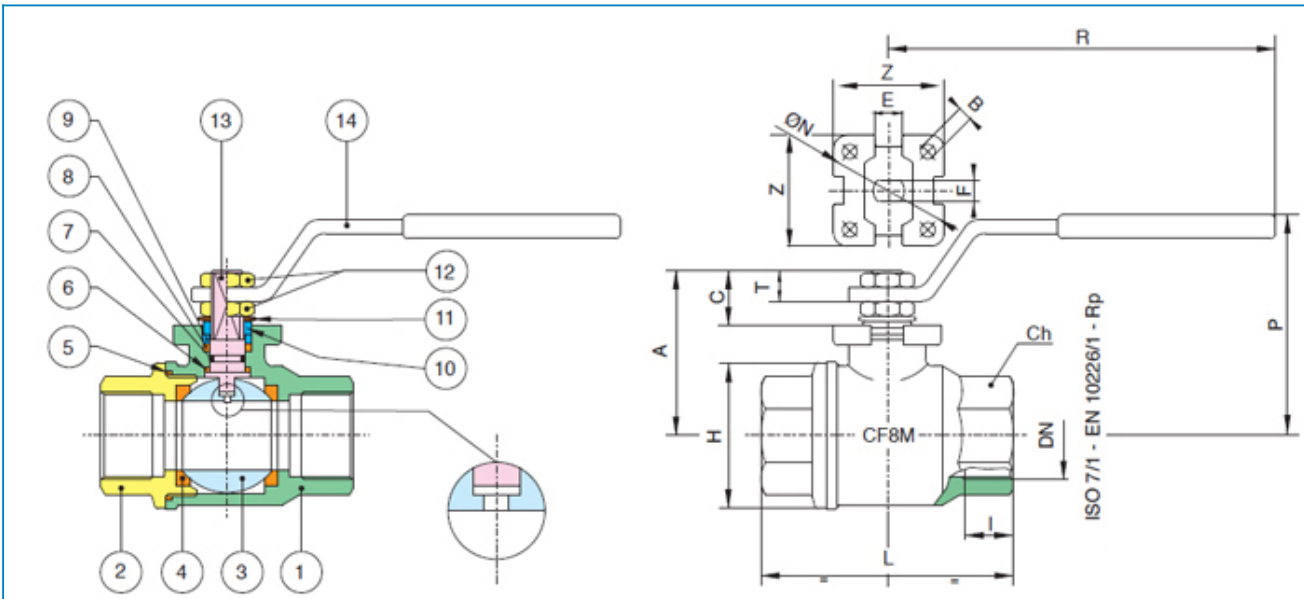

POS.	PART NAME	MATERIALE-MATERIALS MATERIAUX-WERKSTOFF- MATERIAL	N°P
1	BODY	A351-CF8M	1
2	END CONNECTION	A351-CF8M	1
3	BALL	A479-Tp316/A351-CF8M	1
4	BALL SEAT	P.T.F.E	2
5	SEAT	P.T.F.E	1
6	THRUST WASHER	P.T.F.E	1
7	O-RING	E.P.D.M.	1
8	STEM SEAT	P.T.F.E	1
9	PACKING GLAND	INOX AISI 303 (1/8" - 2")-CARBON STEEL (2"1/2 - 4")	1
10	END STOP	INOX AISI 430 (1/8" - 2")-CARBON STEEL (2"1/2-4")	2-1
11	SPRING WASHER	CARBON STEEL (2"1/2-3"-4")	2
12	NUT	A182-F304 (1/8" - 2")-CARBON STEEL (2"1/2 - 4")	2
13	STEM	A479-Tp316	1
14	HANDLE	INOX AISI 430 (1/8" - 2") CARBON STEEL (2"1/2-4")	1

MISURA SIZE	DN	BOX	I	L	H	Ch	R	P	A	C	T	E	F	ØN	B	Z	Kv	PN	Kg
1/8"	6	10	7,7	55	30	ES.22	110	50	35	13,5	9	8	5	36	5,5	36	5	140	0,26
1/4"	8	10	11	55	30	ES.22	110	50	35	13,5	9	8	5	36	5,5	36	5,5	140	0,26
3/8"	10	10	11,4	55	30	ES.22	110	50	35	13,5	9	8	5	36	5,5	36	8,5	140	0,44
1/2"	15	10	15	66	36	ES.27	110	53	38	13,5	9	8	5	36	5,5	36	19,2	140	0,33
3/4"	20	5	16,3	79	45	ES.32	131	68	51	15	10	10	7	42	5,5	42	35,0	105	0,60
1"	25	6	19,1	93	54	OT.41	174	79	60	19,5	12,5	12	8	42	5,5	42	64,5	105	1,01
1"1/4	32	2	21,4	100	64	OT.50	174	83	64,5	19,5	12,5	12	8	42	5,5	42	103,8	64	1,31
1"1/2	40	2	21,4	110	80	OT.55	250	100	79	24	16,5	16	10	50	6,5	50	174,0	64	2,15
2"	50	2	25,7	131	95	OT.70	250	107	86	24	16,5	16	10	50	6,5	50	301,3	64	3,25
2"1/2	65	1	30,2	159	122	OT.90	321	126	104	28,5	18,5	20	14	70	M8	64	545,7	25	6,81
3"	80	1	33,3	185	144	OT.105	321	137	114	28	18	20	14	70	M8	64	872,5	25	10,20
4"	100	1	39,3	222	177	OT.130	381	156	137	34,5	22	24	18	102	M10	92	1363,3	25	18,70