



Cat.no.:E-PS



Cat.no.:E-GGC



Cat.no.:E-TMBV



Cat.no.:E-FBV



Cat.no.:E-DOV



Cat.no.:E-TOV



Cat.no.:E-PLV

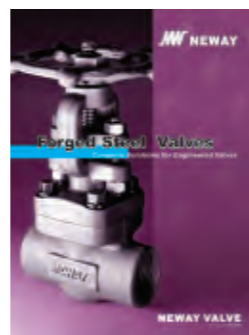

Cat.no.:E-FSV



Cat.no.:E-DAV



Cat.no.:E-CPS

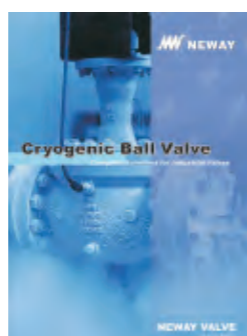

Cat.no.:E-CBV



Cat.no.:E-PV

NW NEWAY
NEWAY VALVE (SUZHOU) CO., LTD.

No.666 Taishan Road, New District,
Suzhou, P.R. China
Post Code: 215129
Tel: 86-512-666-51365
Fax: 86-512-666-18930-2102
E-Mail: overseas.sales@neway.com.cn
http://www.newayvalve.com

Distributed by:

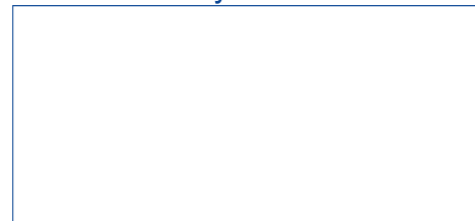

Cat.no.:E-FBV-2019

NW NEWAY

Floating Ball Valve

Complete Solutions for Introduction Valves



NEWAY VALVE

Cat.no.:E-FBV-2019

Table of Contents

Introduction

- 1 Quality Commitment
- 2 Standard and Product Range
- 3 Technical Innovation
- 4 Material Foundries
- 5 Advanced Manufacturing & Quality Control
- 6~7 How to order
- 8 Design Features
- 9 Low Emission Control
- 10 Product Overview

BA Series Ball Valve

- 11 Design Features
- 12~13 Materials and Structures

- 14 Reduced Port, Uni-body, Cast Steel, Side Entry Design

B Series Ball Valve

- 15 Design Features
- 16~17 Materials and Structures

- 18~19 Two-piece, Split Body, Cast Steel, Side Entry Design

BB Series Ball Valve

- 20 Design Features
- 21~22 Materials and Structures

- 23~27 Two-piece, Split Body, Forged Steel, Side Entry Design

BC Series Ball Valve

- 28 Design Features
- 29~30 Materials and Structures

- 31~32 Three-piece, Split Body, Forged Steel, Side Entry Design

Engineering Data

- 33 Flow Coefficient (Cv Value)
- 34 Pressure Temperature Chart
- 35 Operating Torque
- 36 NEWAY Factory



Complete Solutions for Industrial Valves

As a global leader of valve manufacturing, Neway (SSE:603699) is dedicated to the production, research, and development of industrial valves. Neway is committed to providing complete valve solutions to all industries through advanced engineering and innovation.

Neway's product line includes Ball, Butterfly, Gate, Globe, Check, Nuclear, Control, Subsea, Safety valves. Our high quality standards and innovative ability are recognized by many global end users and EPCs. Neway valves are utilized in a wide variety of industries and working conditions such as Refining, Chemical, Coal Chemical, Offshore(including subsea), Air Separation, LNG, Nuclear Power, Power Generation, and Pipeline Transmission applications.

Facilities & Service

Neway has developed a sophisticated multi-plant management system operating one valve assembly plant, one API6A valve plant, three foundries, and one R&D center. Our largest assembly plant was expanded in 2013, and it now covers 35,000 square meters.

Advanced software (ANSYS, FE-Safe, CF-Design, Siemens PLM and NX) is applied here at Neway for the Research & Development of products. We use SAP to control the traceability and status of all products during the manufacturing process. In order to ensure the safety, eco-friendliness, and reliability of our products, we use the most advanced fire-safe, cryogenic, high pressure, and fugitive emission test equipment.

As part of Neway's global strategy, to provide better service to our customers, we have established our overseas subsidiaries in USA, Netherlands, Italy, Singapore, and Dubai along with over 80 agents and distributors worldwide.

High Quality, High Value

Neway is dedicated to the pursuit of "Zero Defect". We maintain a quality management system that encompasses our entire operation from order entry, to final inspection. Through Neway's continuous efforts, our products have achieved industrial certificates including ISO 9001, API 6A, API 6D, CE/PED, ASME N & NPT, ISO 15848-1,TA-Luft, API 641, ABS, CU-TR, and Fire-Safe approvals.

Introduction

In this catalogue, you will find the latest developed NEWAY Ball Valves, which include 4 different designs:

- BA series 1PC uni-body floating type
- B series 2PC cast steel floating type
- BB series 2PC forged steel floating type
- BC series 3PC forged steel floating type



Neway recognizes the importance of valve quality for the safety and protection of personnel health and property. It is our quality commitment to focus our resources to provide our customers with first class products at a competitive price, designed, manufactured, inspected and tested in accordance with our customers specifications and complying with all international standards.

Current industrial standards do not always take into consideration the likelihood and consequences of possible deterioration in service, related to specific service fluids or the external environments in which they operate. Therefore we request that our customers communicate with our engineering department. Our valve optimization program continuously strives to provide valves that withstand deterioration in service, and ensure safety over the valves expected lifetime.

Design and Inspection Standard:

Pressure-Temperature Ratings	ASME B16.34, ASME B16.5 (Class 400), API 602 (Class 800)	
Shell Wall Thickness	ASME B16.34	
Face-to-face Dimensions	Flange	ASME B16.10
	Socket Weld & NPT	Manufacture Std.
End Connection Dimensions	Flange	ASME B16.5
	Butt-Weld	ASME B16.25
	Socket Weld	ASME B16.11
	NPT	ASME B1.20.1
Pressure Test	API 598 or API 6D (Option)	
Fire Test	API 607 or API 6FA (Option)	
Marking	MSP-SP 25	
Surface Quality	MSP-SP 55	
Sour Service	NACE Std. (MR 0175 or MR 0103 or ISO 15156)	
Low Fugitive Emission	ISO 15848, TA-Luft, SPE 77/312, API 641	

Product Range:

Product Coding	Class	Size											
		1/2"	3/4"	1"	1-1/2"	2"	2-1/2"	3"	4"	6"	8"	10"	
BA	150	●	●	●	●	●	●	●	●	●	●	●	●
	300	●	●	●	●	●	●	●	●	●	●	●	●
B	150	●	●	●	●	●	●	●	●	●	●	●	●
	300	●	●	●	●	●	●	●	●	●	●	●	●
BB	150	●	●	●	●	●	●	●	●	●	●	●	●
	300	●	●	●	●	●	●	●	●	●	●	●	●
	400	●	●	●	●	●	●	●	●	●	●	●	●
	600	●	●	●	●	●	●	●	●	●	●	●	●
	900	●	●	●	●	●	●	●	●	●	●	●	●
	1500	●	●	●	●	●	●	●	●	●	●	●	●
	2500	●	●	●	●	●	●	●	●	●	●	●	●
BC	150	●	●	●	●	●	●	●	●	●	●	●	●
	300	●	●	●	●	●	●	●	●	●	●	●	●
	600	●	●	●	●	●	●	●	●	●	●	●	●
	800	●	●	●	●	●	●	●	●	●	●	●	●
	900	●	●	●	●	●	●	●	●	●	●	●	●
	1500	●	●	●	●	●	●	●	●	●	●	●	●
	2500	●	●	●	●	●	●	●	●	●	●	●	●

- Design Standard: ASME B16.34, ISO 17292, API 608
- Design Standard: ASME B16.34
- Design Standard: ASME B16.34, API 6D
- Design Standard: ASME B16.34, ISO17292, API 608, API 6D

NEWAY Technical Center focuses on providing outstanding quality products and developing new lines. We have a internat well-trained engineering team, supported by a comprehensive network to link the entire operations of design, manufacturing and administration.

NEWAY design philosophy is to provide safe and cost-efficient valves. We introduce the Ansys, Fe-safe, CF-design and NX software into all our new product design research which include the advanced finite element analysis, fluid and fatigue analysis to virtually verify the new design prior to production, which has resulted in dramatically shortening development duration and assure a safe and cost-efficient final product.

NEWAY technical personnel are always ready to offer on line or on site technical training and support for all of its distributors, agents and end users.



Low Temperature Test



Cv Value on-line Test



High Velocity Oxygen Fuel Equipment



Fire Safe Test

Fire safe is Neway's standard design. All series of Neway floating soft-seated valves has been witnessed and certified by Lloyd's Register. The certifications and test reports are available upon request. Approved by Lloyd's, the computer-controlled facility collects data of fire-safe test, capable of testing and verifying Neway's all floating ball valves per API6FA and API607.



Valve casting quality is of prime importance for product life, personnel and environmental safety, particularly in high temperature and high pressure service as valve serves as one of pressure-containing equipment in process-controlled pipeline. Thus, castings are always certified firstly by the customers requiring strictly before a valve manufacturer is pre-qualified and approved as a qualified supplier.

Compared with most of other competitors, we own three foundries: two of them work on produce large-sized sand castings by organic ester water glass, and two of them are for production of small-sized investment castings by lost-wax casting. Besides, each is equipped with all kinds of quality inspection facilities, such as spectrum instrument, non-destructive test machinery, and mechanical property test device. Against such backdrop, Neway can monitor the whole process of manufacture to ensure product quality, delivery and competitive price and enable Neway to remain a creditable supplier for every customer.



Automatic Line Form



Sand Mixing Machine



Forklift Type Heat Treatment Equipment

Supply Range & capacity :

Plant Name	Dafeng Foundry	Suzhou Foundry
Process Technology	Lost wax investment casting	Organic ester water glass sand casting
Size Range(in)	2" ~10"	2" ~76"
Pressure Rating	ANSI Class 150~600	ANSI Class 150~2500
Weight(Kg)	1~180	100~7000
Material	WCA, WCB, WCC, LCA, LCB, LCC, LC3, WC6, WC9, C5, C12, CA15, C12A, CF8, CF8M, CF3, CF3M, CN7M, CG3m, CG8m, CF8C, CF10, Duplex Steel, 4A, 5A, 6A etc.	
Monthly Capacity(Ton)	1500	1800
Quality Certificate	ISO9001, CE/PED, AD W0, Norsok	ISO9001, CE/PED, Norsok, API20A, CNAS, ISO14001, OHSAS18001, AD2000, Marine by DNV/ LR/ BV/ ABS

The latest computer technology has been extensively applied in NEWAY manufacturing, which includes a large number of numeric control machines (machining center, CNC horizontal and vertical lathe and CNC drilling machine) and ERP management system. Additionally, the data through all factories have been connected and shared. These facilitate resource integration, boost productivity, evidently enhancing machining quality and tightening process control.



NEWAY developed comprehensive and advanced inspection and test facilities to control the quality from rough castings or forgings to final products, which enable us to perform radiographic test, liquid penetrant test, magnetic-particle test, spectrum analysis, Material Positive Identification (MPI), impact test, tensile test, hardness test, fire safe test, cryogenic test, vacuum test, low fugitive emission test, high pressure gas test, ultrasonic testing and hydrostatic test.



How to order

Example:



Neway part numbers are designed to cover essential features. When ordering, please show the part numbers and a detailed description to avoid misunderstanding of your requirements.

Following descriptions provide a basic guideline in valve specification:

① Valve Size

Full bore:

NPS	3/8	1/2	3/4	1	1-1/4	1-1/2	2	2-1/2	3	3-1/2	4	5	6	8	10	12
DN	10	15	20	25	32	40	50	65	80	90	100	125	150	200	250	300

Reduced bore:

NPS	3/8*1/4	1/2*3/8	3/4*1/2	1*3/4	1-1/2*1	2*1-1/2	2-1/2*2	3*2	4*3	6*4	8*6	10*8	12*10
DN	10*6.4	15*10	20*15	25*20	40*25	50*40	65*60	80*50	100*80	150*100	200*150	250*200	300*250

② Valve Type

Symbol	Valve Type	Symbol	Valve Type
BA	Uni-body Floating ball valve - cast	BC	3-pcs floating ball valve - forged
B	2-pcs Floating ball valve - cast	BB	2-pcs floating ball valve - forged

③ ASME Class

Code	1	3	4	6	8	9	15	25
Class (LB)	150	300	400	600	800	900	1500	2500

④ End Connection

Symbol	End	Symbol	End
R	Raised face flanged end	S	Socket weld end
J	RTJ flanged end	N	Screwed end
B	Butt-weld end	SN	Socket Weld/Screwed End
F	Flat Face Flanged End	NC	55° Taper Screwed End

⑤ Operator

Symbol	Description	Symbol	Description
	Lever	BS	Bare shaft
G	Gear operator	H	Hydraulic actuator
M	Electric actuator	L	Gas over oil actuator
P	Pneumatic actuator	C	Chainwheel

⑥ Body Material

Material	C40	L70	S40	S41	S42	S43	N50	D40
ASTM Ref	A105N	A350 LF2	A182 F304	A182 F316	A182 F304L	A182 F316L	Alloy 20	A182 F51

Material	C00	L20	S00	S01	S02	S03	N04	D01
ASTM Ref	A216 WCB	A352 LCB	A351 CF8	A351 CF8M	A351 CF3	A351 CF3M	A351 CN7M	A890 4A

⑦ Trim Code

Seat		O-ring		Stem		Ball		Packing	
Code	Material	Code	Material	Code	Material	Code	Material	Code	Material
1	PTFE	2	VITON	1	F6a	1	F6a	1	PTFE
3	PEEK	3	VITON AED	2	F304	2	F304	2	Graphite
7	NYLON 12	4	VITON B	3	A105/ENP	3	A105/ENP	9	Garlock(low emission)
8	PCTFE	5	HNBR	4	17-4PH	4	17-4PH		
C	FILLED PTFE	8	VITON GLT	5	AISI 4140/ENP	5	AISI 4140/ENP		
F	TFM1700	N	No O-Ring	6	F316	6	F316		
				9	LF2/ENP	9	LF2/ENP		
				A	F51	A	F51		

Note: Other materials upon request.

Blow-out Proof Stem

The lower end of the stem is T-shaped structured, protected by boss of body, which assures stem retention at any pressure and acts as backseat. (Fig.1)

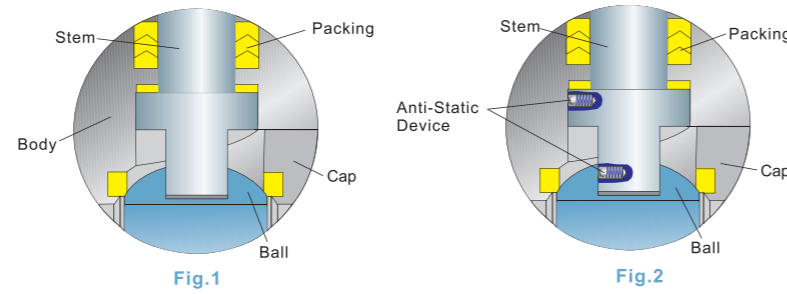

Anti-static Device

A spring-loaded plunger fitted on stem keeps constant contact between ball, stem and body to create an electric path to transfer charges, avoiding acceleration of static electricity as a result of friction during valve on-off. Such build-up is utterly hazardous to some services. (Fig.2)

Position Indicator

Double D stem head design provides mounting of the lever always in parallel to the flow passage. Misalignment of the lever is thus prevented. (Fig.3)

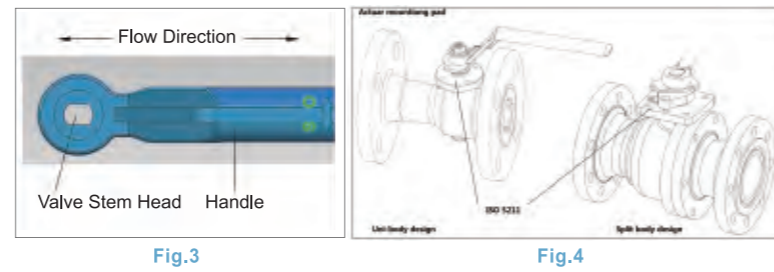

Locking Device

Facility for mounting a locking device for prevention of accidental valve operation is provided.

ISO 5211 Actuator Mounting Pad

Ball valves always furnished with integral actuator mounting pad designed according to ISO 5211. (Fig.4)

Fire Safe - Metal to Metal Sealing

When soft seats are decomposed or ruined by fire, the ball, driven by pressure, comes into contact with the metal lip seal seat of original soft seat, creating a metal-to-metal seal to shut off service fluids and minimize internal leakage.

Additionally, the fire safe metal seat prevents damage the medium imposed on soft seat and minimizes creep of nonmetal materials. All the NEWAY floating valves are designed to be fire safe per API 607 and are tested and certified by the third party.

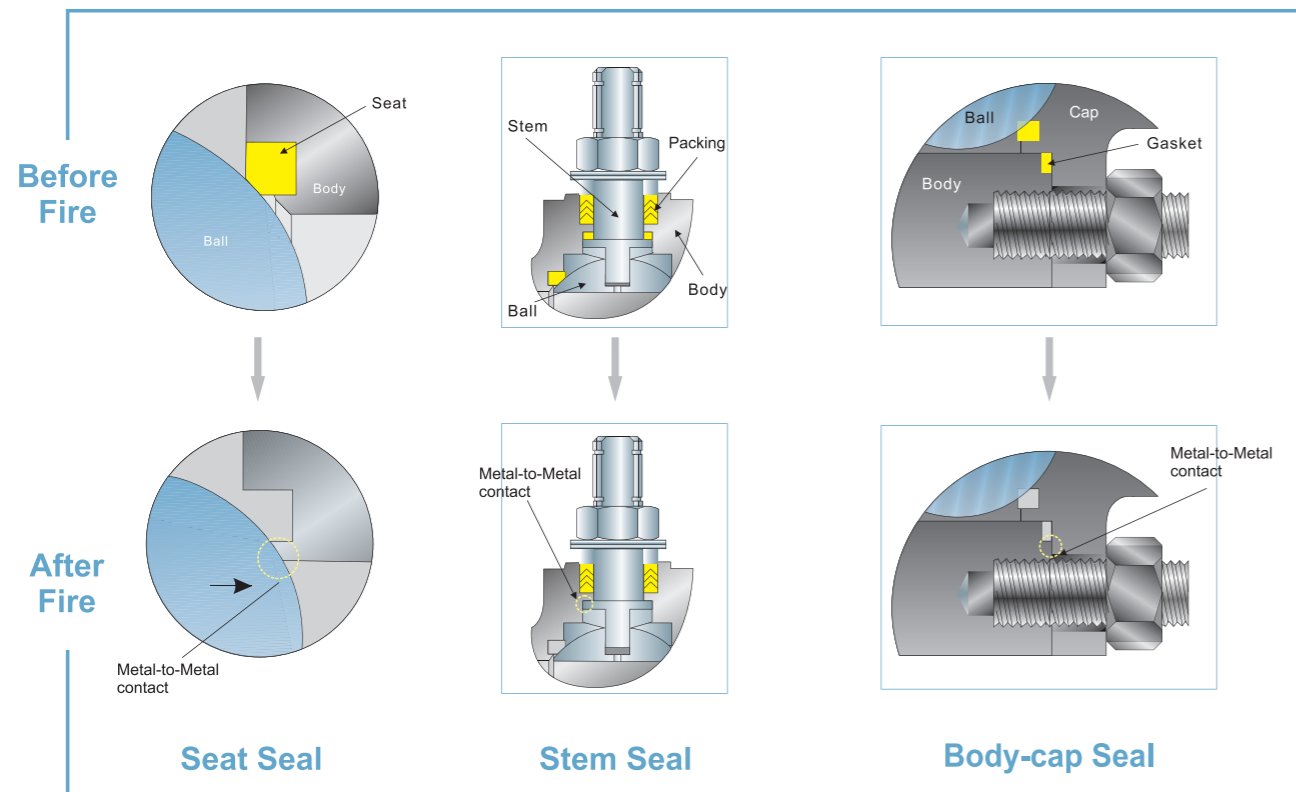

Modern industry sectors are challenged by valve fugitive emission to control service fluids released from the valve and curb environmental degradation. Therefore, emission control features NEWAY floating ball valves of B, BA, BB and BC Series. Low emission packing is assembled, whose max. leaking rate of design and test stands at 100 PPM (Test is performed according to ISO15848)

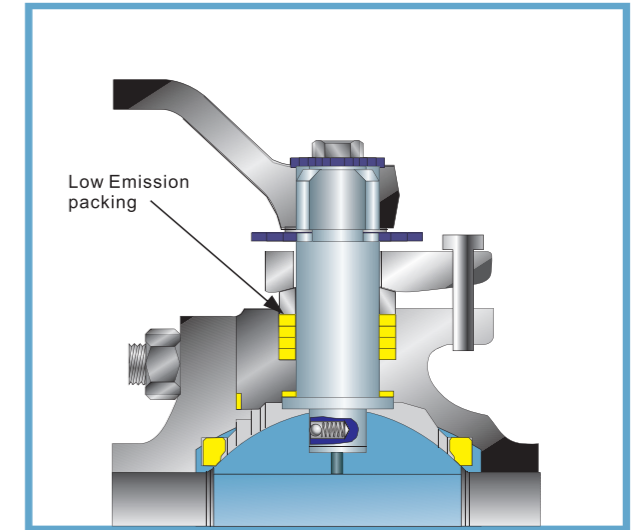

Roughness control over stem and packing

Stem surface roughness is strictly restricted between Ra0.4 and Ra0.8, which ensures entry of graphite packing powder into tiny stem scratches to function as a lubricator, minimizing leakages around stem. Max. roughness of stuffing box is RA3.2, which is a proper value to hold packing ring in place and result in better sealing performance.

Low Emission Packing

The packing is combination of parallel and vertical layer which is made of die-formed graphite ring processed by flexible graphite, characterizing heat resistance, less stress relaxation and low creep. The special structure means low friction on rotary stem, providing stabilized seal capability for the valve for a long time under frequent functioning.



For low-temperature and cryogenic service, the standard V shape PTFE packing rings are installed for low emission control.

Neway offers four series of floating ball valves:

- BA Series, one piece, side-entry, cast steel
- B Series, two-piece, side-entry, cast steel
- BB Series, two-piece, side-entry, forged steel
- BC Series, three-piece, side-entry, forged steel

NEWAY floating ball valves function in service ranging from -50°C to 200°C (from -58°F to 392°F), with size which varies from 1/2 inch to 12 inch (15mm~300mm) and pressure range of ASME Class150~Class 2500 (2.0Mpa~25.0Mpa). Our floating ball valves are capable of fulfilling sour service requirements stated in NACE MR0175.



Pneumatic Actuator Ball valve



Pneumatic Actuated Ball Valve



1PC Cast Steel Design



Stainless Steel



3 PC Floating Ball Valve



2PC Forged Steel Design



Hastelloy Ball Valve



2PC Cast Steel Design

This is an illustrated of typical regular port, uni-body, floating type ball valve to exhibit the basic design concept. The actual design of a valve may be slightly different from this illustration depending on its size and pressure class.

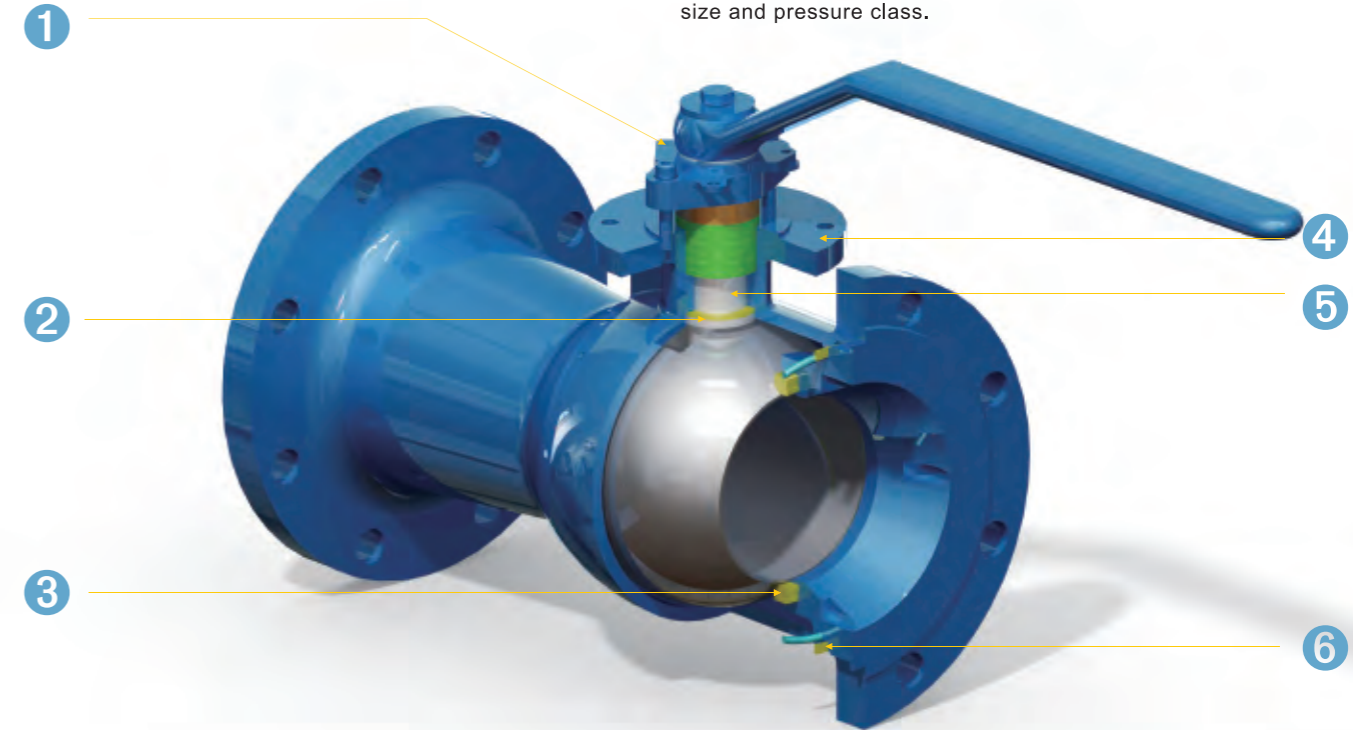

2x1-1/2 BA 1 R

- 1 Reliable Flow Locking Device: Valve is equipped with an integral locking device to secure flow.
- 2 Blow-out proof stem: The lower end of the stem is T-shaped structured, protected by boss of body, which assures stem retention against any pressure.
- 3 Fire Safe Design: Metal to metal sealing shuts off valve flow when soft sealing materials are destroyed by fire.
- 4 ISO5211 connection dimension: actuator installation is simplified by using connection dimension recognized in international standards.
- 5 Double "D" Stem Head: ensures handle lever will always be mounted correctly, parallel to the media flow, indicating valve open and closed positions.
- 6 Emission-free Gasket: Low-emission graphite is employed in gasket to eliminate leakage.

APPLICATIONS

- Refinery
- Petrochemical
- Paper
- Chemical
- Pharmaceutical
- Food and Beverage

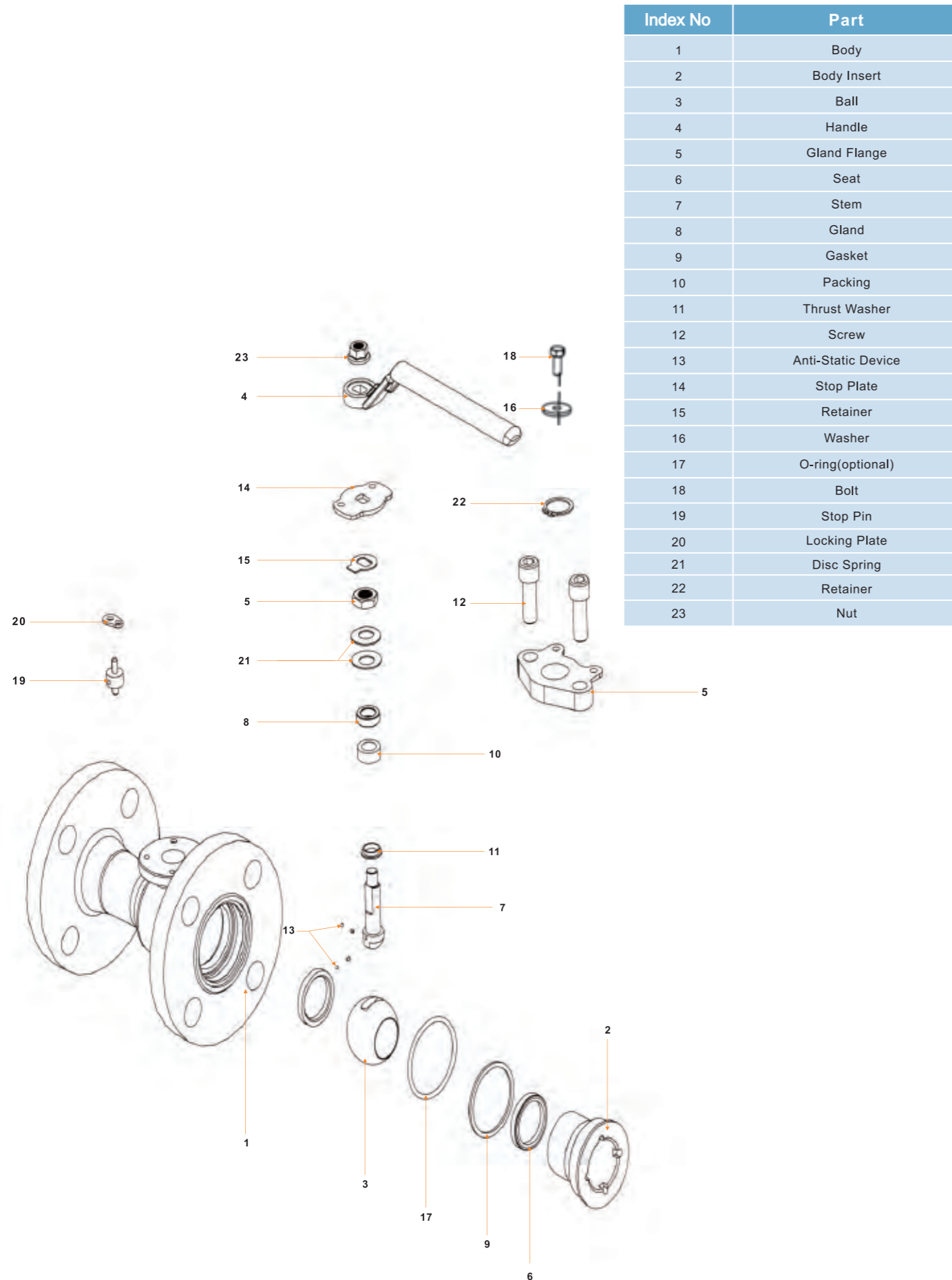

Index No	Part
1	Body
2	Body Insert
3	Ball
4	Handle
5	Gland Flange
6	Seat
7	Stem
8	Gland
9	Gasket
10	Packing
11	Thrust Washer
12	Screw
13	Anti-Static Device
14	Stop Plate
15	Retainer
16	Washer
17	O-ring(optional)
18	Bolt
19	Stop Pin
20	Locking Plate
21	Disc Spring
22	Retainer
23	Nut

No	Part	Carbon Steel (Non-Sour)	Stainless Steel	Carbon Steel (Sour Service)	Low Temperature Carbon Steel
1	Body	ASTMA216-WCB	ASTMA351-CF8M	ASTMA216-WCB	ASTMA352-LCB
2	Body Insert	ASTMA216-WCB	ASTMA351-CF8M	ASTMA216-WCB	ASTMA352-LCB
3	Ball	ASTM A182 F6a	ASTMA182-F316	ASTM A182 F6a	ASTMA182-F316
4	Handle	Carbon Steel	Carbon Steel	Carbon Steel	Carbon Steel
5	Gland Flange	ASTMA216-WCB	ASTMA351-CF8	ASTMA216-WCB	ASTMA352-LCB
6	Seat	PTFE	PTFE	PTFE	PTFE
7	Stem	ASTMA182-F6a	ASTMA182-F316	ASTMA182-F6a	ASTMA182-F316
8	Gland	ASTM A276-304L	ASTM A276-304L	ASTM A276-304L	ASTM A276-304L
9	Gasket	Flexible Graphite	Flexible Graphite	Flexible Graphite	Flexible Graphite
10	Packing	Graphite	Graphite	Graphite	Graphite
11	Thrust Washer	PTFE	PTFE	PTFE	PTFE
12	Screw	ASTMA193-B7	ASTM A193-B8 CI2	ASTMA193-B7M	ASTMA320-L7M
13	Anti-Static Device	S.S.	S.S.	S.S.	S.S.
14	Stop Plate	Carbon Steel	S.S.	Carbon Steel	Carbon Steel
15	Retainer	S.S.	S.S.	S.S.	S.S.
16	Washer	Carbon Steel	S.S.	Carbon Steel	Carbon Steel
17	O-ring(optional)	Viton A	Viton A	Viton A	HNBR
18	Bolt	Carbon Steel	S.S.	Carbon Steel	Carbon Steel
19	Stop Pin	Carbon Steel	S.S.	Carbon Steel	Carbon Steel
20	Locking Plate	Carbon Steel	S.S.	Carbon Steel	S.S.
21	Disc Spring	Carbon Steel	S.S.	Carbon Steel	Carbon Steel
22	Retainer	Carbon Steel	S.S.	Carbon Steel	Carbon Steel
23	Nut	Carbon Steel	S.S.	Carbon Steel	Carbon Steel

ISO5211 connection dimension: actuator installation is simplified by using connection dimension recognized in international standards.

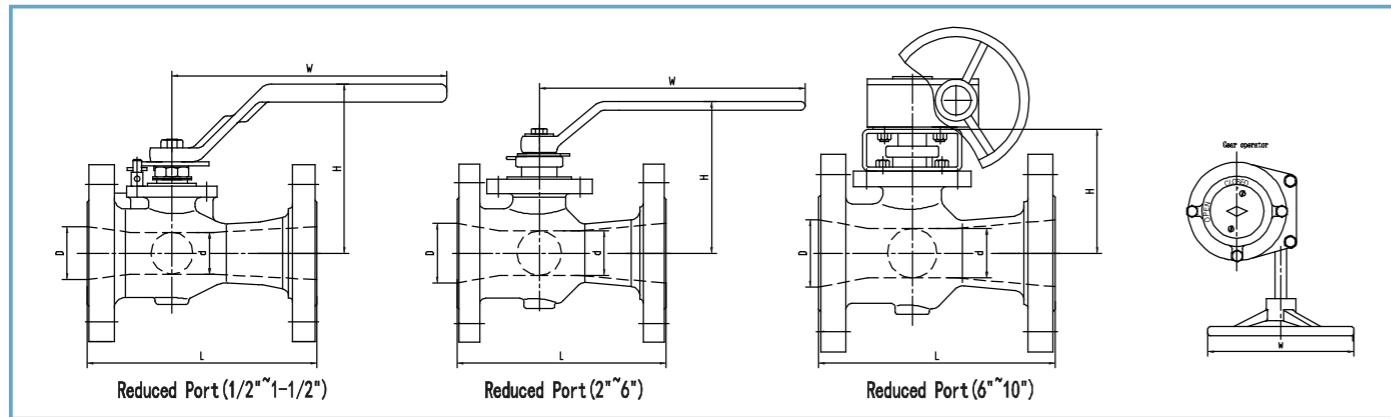

Class 150 Dimension and Weight

Size		d		D		L		H		W		Weight	
NPS	DN	in	mm	in	mm	in	mm	in	mm	in	mm	lb	KG
1/2*3/8	15*10	0.37	10	0.50	13	4.25	108	1.75	44.50	4.72	145	3.3	1.5
3/4*1/2	20*15	0.50	13	0.75	19	4.61	117	2.11	53.50	5.51	165	5.5	2.5
1*3/4	25*20	0.75	19	1.00	25	5.00	127	2.42	61.50	5.51	165	6.6	3.0
1-1/2*1	40*25	1.18	30	1.50	38	6.50	165	3.15	80	6.30	215	11.0	5.0
2*1-1/2	50*40	1.50	38	2.00	51	7.01	178	4.17	106	10.43	265	19.2	8.7
2-1/2*2	65*50	2.00	51	2.50	64	7.52	191	4.72	120	10.43	265	27.3	12.4
3*2-1/2	80*65	2.50	64	3.00	76	7.99	203	5.67	144	10.43	285	36.8	16.7
4*3	100*80	3.00	76	4.00	102	9.02	229	6.54	166	11.81	300	53.8	24.4
6*4	150*100	4.50	114	6.00	152	10.51	267	8.39	213	15.75	*300	110.2	50.0
8*6	200*150	6.00	152	8.00	203	11.50	292	20.71	526	11.81	*400	222.7	101.0
10*8	250*200	7.36	187	10.00	254	12.99	330	21.65	550	16	*400	330.7	150.0

Class 300 Dimension and Weight

Size		d		D		L		H		W		Weight	
NPS	DN	in	mm	in	mm	in	mm	in	mm	in	mm	lb	KG
1/2*3/8	15*10	0.37	10	0.50	13	5.51	140	1.75	44.50	4.72	145	6.2	2.8
3/4*1/2	20*15	0.50	13	0.75	19	5.98	152	2.11	53.50	5.51	165	7.9	3.6
1*3/4	25*20	0.75	19	1.00	25	6.50	165	2.42	61.50	5.51	165	10.6	4.8
1-1/2*1	40*25	1.18	30	1.50	38	7.48	190	3.15	80	6.30	215	21.2	9.6
2*1-1/2	50*40	1.50	38	2.00	51	8.50	216	4.17	106	10.43	265	24.3	11.0
2-1/2*2	65*50	2.00	51	2.50	64	9.49	241	4.72	120	10.43	265	33.3	15.1
3*2-1/2	80*65	2.50	64	3.00	76	11.14	283	5.67	144	10.43	285	49.6	22.5
4*3	100*80	3.00	76	4.00	102	12.01	305	6.54	166	11.81	300	81.6	37.0
6*4	150*100	4.50	114	6.00	152	15.87	403	8.39	213	11.81	*300	159.8	72.5
8*6	200*150	5.67	144	8.00	203	16.50	419	20.71	526	15.75	*400	275.6	125.0
10*8	250*200	7.36	187	10.00	254	17.99	457	21.65	550	15.75	*400	451.9	205.0

*Gearbox operated

This is an illustration of typical full port, split body, floating type ball valve to exhibit the basic design concept. The actual design of a valve may be slightly different from this illustration depending on its size and pressure class.

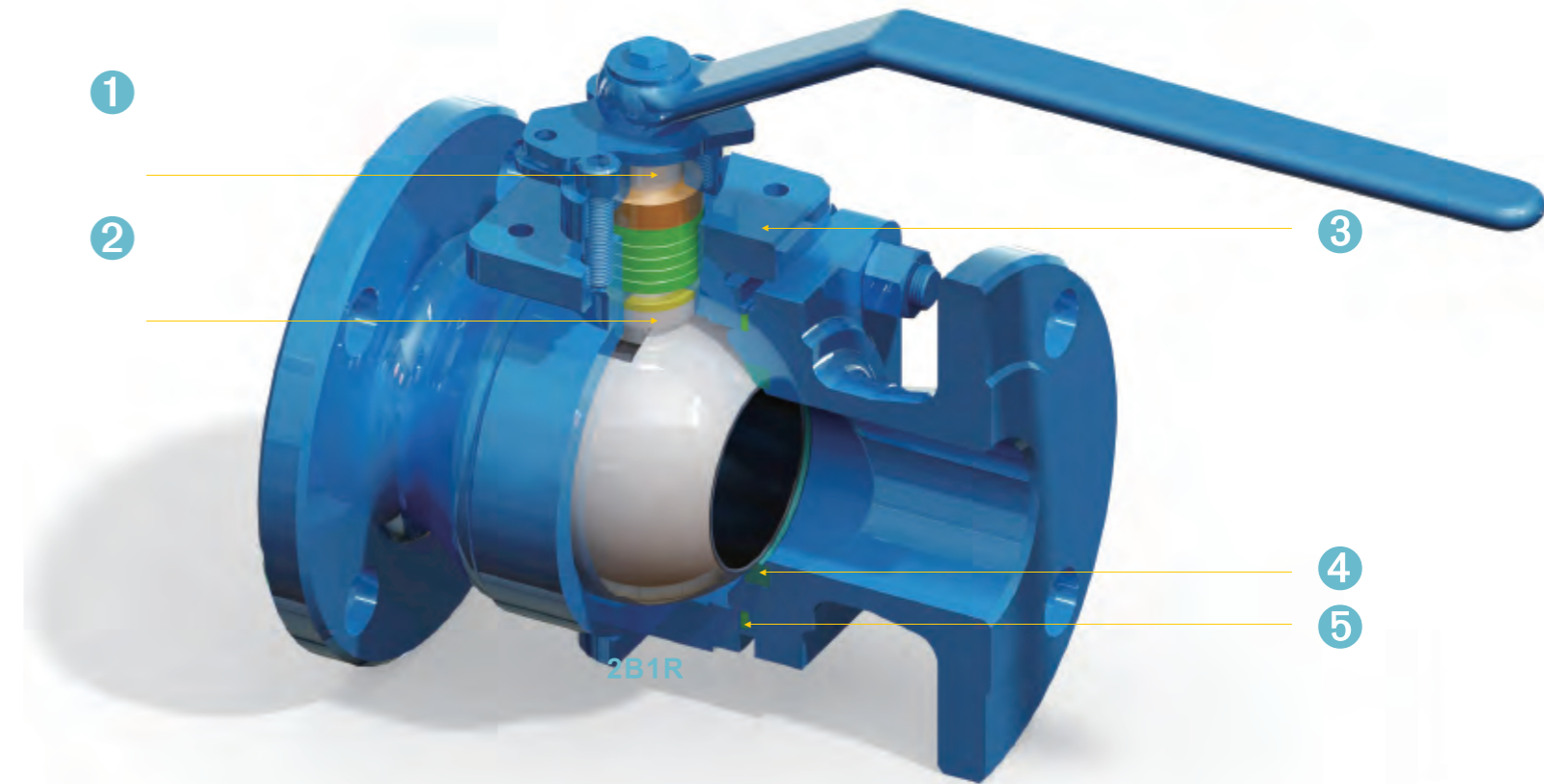

- 1 Double "D" Stem Head: ensures handle lever will always be mounted correctly, parallel to the media flow, indicating valve open and closed positions.
- 2 Blow-out proof stem: The lower end of the stem is T-shaped structured, protected by boss of body, which assures stem retention against any pressure.
- 3 ISO5211 connection dimension: actuator installation is simplified by using connection dimension recognized in international standards.
- 4 Fire Safe Design: Metal to metal sealing shuts off valve flow when soft sealing materials are destroyed by fire.
- 5 Emission-free Gasket: Low-emission graphite is employed in gasket to eliminate leakage.

APPLICATIONS

- Refinery
- Petrochemical
- Power
- Chemical
- Pharmaceutical

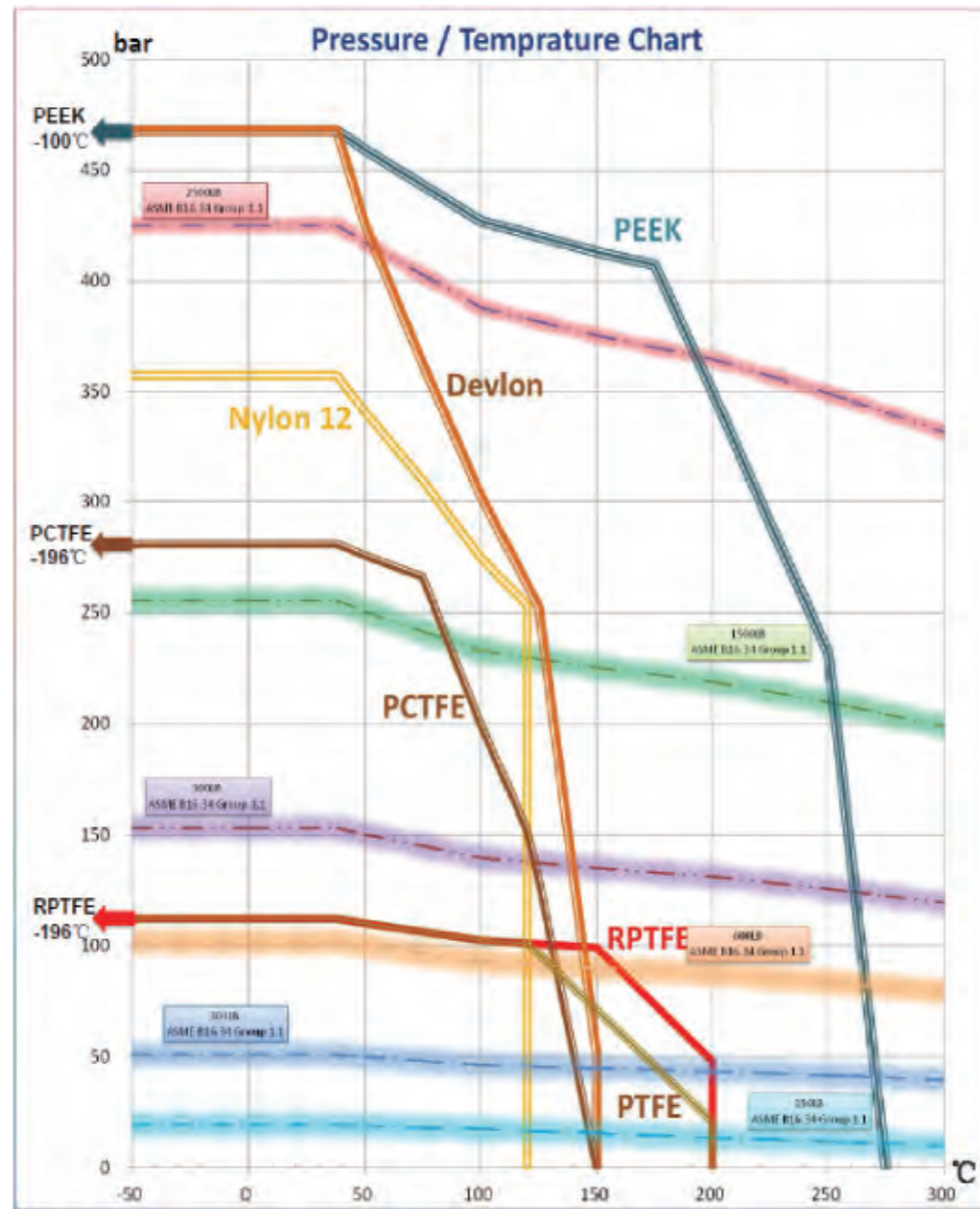

Note: Other materials are available upon request.

If the operating condition is beyond the range above, please contact NEWAY's technical team.
NEWAY reserves the right to update without notice.

Operating Torque

Size	Class 150		Class 300		Class 400		Class 600	
	N.m	Ft/Lbs	N.m	Ft/Lbs	N.m	Ft/Lbs	N.m	Ft/Lbs
1/2	5	3.69	6	4.43	11	8.12	16	11.81
3/4	8	5.90	10	7.38	14	10.33	20	14.76
1	15	11.07	17	12.55	29	21.40	42	31.00
1-1/4	30	22.14	45	33.21	50	36.90	72	53.14
1-1/2	35	25.83	45	33.21	62	45.76	90	66.42
2	40	29.52	55	40.59	90	66.42	130	95.94
2-1/2	70	51.67	90	66.42	104	76.75	150	110.70
3	90	66.42	120	88.56	138	101.84	200	147.60
4	180	132.84	230	169.74	265	188.19	370	273.06
6	480	354.27	930	686.34				
8	900	664.26	1930	1424.34				
10	1800	1328.51	4000	2952.25				

Size	Class 800		Class 900		Class 1500		Class 2500	
	N.m	Ft/Lbs	N.m	Ft/Lbs	N.m	Ft/Lbs	N.m	Ft/Lbs
1/2	19	14.02	25	18.45	32	23.62	56	41.33
3/4	33	24.35	40	29.52	60	44.28	95	70.12
1	65	47.97	80	59.05	140	103.33	175	129.16
1-1/4	100	73.81	115	84.88	155	114.40		
1-1/2	130	95.94	140	103.32	171	126.21		
2	187	138.01	336	247.99	420	309.96		
3			431	318.08				

Note:

- Torque is calculated based on ambient temperature, with RPTFE seat for Class 150~Class 800, NYLON for Class 900~1500, PEEK for Class 2500, NYLON (4" in size) for Class 600.
- Torque shown in this table is the reference for actuator selection. A safety factor of 1.3~1.5 is recommended for identifying actuator sizing.
- For cryogenic service, torque shall be increased about 2~2.5 times.
- Torque may vary with fluids and trim materials. Contact NEWAY Ball Valve Engineering Department for specific requirements.

NEWAY Head Office

Total area: 2,295sqm
Office area: 6,885sqm

Founded in 2014



NEWAY Manufacturing Base

Main products: Ball Valve, Butterfly Valve,
Gate Valve, Globe Valve,
Check Valve, Control Valve

Building area: 230,000 sqm
Work shop: 140,061 sqm

Founded in 2006 and expanded in 2013



NEWAY Foundry (Suzhou)

Main products: Sand Casting
Building area: 112,500 sqm
Work shop: 98000 sqm

Founded in 2008 and expanded in 2015



NEWAY Foundry (Dafeng)

Main products: Lost wax investment casting
Building area: 46,000 sqm
Work shop: 12,000 sqm

Founded in 2004



NEWAY Foundry (Dafeng)

Main products: Lost wax investment casting
Building area: 40,000 sqm
Work shop: 20,000 sqm

Founded in 2008



NEWAY Forging (Liyang)

Main products: Hammer forging, annular forging
Office area: 3,000 sqm
Work shop: 30,000 sqm

Founded in 2017



Seller will replace without charge or refund the purchase price of products provided by Seller which prove to be defective in material or workmanship, provided in each case that the product is properly installed and is used in the service for which Seller recommends it and that written claim, specifying the alleged defect, is presented to the Seller within 18 months from the date of shipment or 12 months after installation, whichever occurs first. Seller shall in no event bear any labor, equipment, engineering or other costs incurred in connection with repair or replacement. The warranty stated in this paragraph is in lieu of all other warranties, either expressed or implied. With respect to warranties, this paragraph states Buyer's exclusive remedy and seller's exclusive liability.